

**STATE OF HAWAII
DEPARTMENT OF TRANSPORTATION
HIGHWAYS DIVISION**

**ADDENDUM NO. 1
for
KAMEHAMEHA HIGHWAY
KAIPAPAU STREAM BRIDGE REPLACEMENT**

FEDERAL AID PROJECT NO. BR-083-1(48)

The following amendments shall be made to the Bid Documents:

A. SPECIAL PROVISIONS

1. Replace Special Provision Table of Contents dated 5/27/21 with the attached Special Provision Table of Contents dated r07/07/21. Added Section 632.
2. Replace Special Provision Section 511 – Drilled Shafts dated 02/24/21 with the attached Special Provision Section 511 – Drilled Shafts dated r07/07/21. Revised Lines 15-18 (maximum water to cement ratio and maximum cementitious content); revised Line 35 (max concrete temperature at time of placement).
3. Replace Special Provision Section 631 – Traffic Control, Regulatory, Warning, and Miscellaneous Signs dated 2/3/20 with the attached Special Provision Section 631 – Traffic Control, Regulatory, Warning, and Miscellaneous Signs dated r07/07/21. Revised Line 43 to add Relocation of Existing Sign.
4. Add attached Special Provision Section 632 – Markers dated r07/07/21.

B. FEDERAL WAGE RATES

1. Replace Federal Wage Rates dated 05/07/2021 with the attached Federal Wage Rates dated 07/02/2021.

C. PROPOSAL SCHEDULE

1. Replace Proposal Schedule pages P-8 to P-19 dated 5/21/21 with the attached Proposal Schedule pages P-8 to P-19 dated r7/07/21.

D. PLANS

1. Replace Plan Sheets No. 14, 20, 26, 31, 35, 37 and 39 with the attached Plan Sheets No. ADD. 14, ADD. 20, ADD. 26, ADD. 31, ADD. 35, ADD. 37 and ADD. 39.

E. PRE-BID MEETING MINUTES

1. Pre-bid meeting attendance and minutes are attached for information.

F. ANSWERS TO QUESTIONS FROM PROSPECTIVE BIDDERS

1. Attached are RFIs and responses for your information.

Please acknowledge receipt of this Addendum No. 1 by recording the date of its receipt in the space provided on page P-4 of the Proposal.



JADE T. BUTAY
Director of Transportation

TABLE OF CONTENTS

Notice To Bidders

Instructions for Contractor's Licensing

Notice of Requirement for Affirmative Action to Ensure
Equal Employment Opportunity (Executive Order 11246)

Disadvantaged Business Enterprise (DBE) Requirements

Required Federal-Aid Contract Provisions

Special Provisions Title Page

Special Provisions:

DIVISION 100 - GENERAL PROVISIONS		
Section	Description	Pages
101	Terms, Abbreviations, and Definitions	101-1a – 101-12a
102	Bidding Requirements and Conditions	102-1a – 102-8a
103	Award and Execution of Contract	103-1a – 103-5a
104	Scope of Work	104-1a – 104-2a
105	Control of Work	105-1a – 105-3a
106	Material Restrictions and Requirements	106-1a
107	Legal Relations and Responsibility To Public	107-1a – 107-7a
108	Prosecution and Progress	108-1a – 108-25a
109	Measurement and Payment	109-1a – 109-2a

DIVISION 200 - EARTHWORK		
Section	Description	Pages
201	Clearing and Grubbing	201-1a
202	Removal of Structures and Obstructions	202-1a – 202-3a
203	Excavation and Embankment	203-1a – 203-3a
204	Excavation and Backfill for Miscellaneous Facilities	204-1a
205	Excavation and Backfill for Bridge and Retaining Structures	205-1a – 205-2a
206	Excavation and Backfill for Drainage Facilities	206-1a
209	Temporary Water Pollution, Dust, and Erosion Control	209-1a – 209-35a
219	Determination and Characterization of Fill Material	219-1a – 219-3a

DIVISION 300 - BASES		
Section	Description	Pages
301	Hot Mix Asphalt Base Course	301-1a
304	Aggregate Base Course	304-1a
305	Aggregate Subbase Course	305-1a

DIVISION 400 - PAVEMENTS		
Section	Description	Pages
401	Hot Mix Asphalt (HMA) Pavement	401-1a – 401-36a
403	Anti-Skid Coating	403-1a – 403-2a
407	Tack Coat	407-1a
411	Portland Cement Concrete Pavement	411-1a

DIVISION 500 - STRUCTURES		
Section	Description	Pages
503	Concrete Structures	503-1a – 503-9a
504	Prestressed Concrete Members	504-1a – 504-3a
507	Railings	507-1a
511	Drilled Shafts	511-1a – 511-29a
512	Prefabricated Steel Beam Bridge	512-1a – 512-9a
530	Temporary Segmental Retaining Wall System	530-1a – 530-11a
540	Very Early Strength Latex Modified Concrete (VESLMC)	540-1a – 540-14a

DIVISION 600 - INCIDENTAL CONSTRUCTION		
Section	Description	Pages
601	Structural Concrete	601-1a – 601-2a
602	Reinforcing Steel	602-1a – 602-2a
603	Culverts and Storm Drains	603-1a
606	Guardrail	606-1a
607	Chain Link Fences and Gates	607-1a
617	Planting Soil	617-1a
621	Rodent Control and Security Services	621-1a – 621-5a
622	Roadway and Sign Lighting System	622-1a – 622-2a
624	Water System	624-1a
626	Manholes and Valve Boxes for Water and Sewer Systems	626-1a

627	Lightweight Cellular Concrete (LCC) Fill for Utilities and Structures	627-1a – 627-2a
628	Shotcrete	628-1a
629	Pavement Markings	629-1a – 629-4a
631	Traffic Control Regulatory, Warning, and Miscellaneous Signs	631-1a
632	Markers	632-1a
636	E-Construction	636-1a
641	Hydro-Mulch Seeding	641-1a – 641-2a
648	Field-Posted Drawings	648-1a
651	Electric System	651-1a – 651-8a
652	Telecommunications System	652-1a – 652-6a
655	Dumped Riprap	655-1a
657	Handling and Disposal of Hazardous Items and Materials	657-1a – 657-2a
665	Pest Control	665-1a – 665-2a
670	Glass Fiber Reinforced Polymer Rebar	670-1a – 670-3a
688	Removal and Disposal of Asbestos Containing Materials (ACM)	688-1a – 688-29a
691	Archaeological Monitoring	691-1a – 691-2a
693	Terminal Impact Attenuator	693-1a
695	Public Educational Campaign	695-1a – 695-3a
699	Mobilization	699-1a

DIVISION 700 - MATERIALS		
Section	Description	Pages
702	Bituminous Materials	702-1a – 702-2a
709	Reinforcing Steel, Wire Rope and Prestressing Steel	709-1a
712	Miscellaneous	712-1a
717	Cullet and Cullet-Made Materials	717-1a – 717-2a
722	Chain Link Fence Materials	722-1a
750	Traffic Control Sign and Marker Materials	750-1a – 750-2a
760	Roadway and Sign Lighting System Materials	760-1a – 760-2a

Hazardous Materials Survey Report – Kaipapau Stream

Limited Hazardous Materials Survey Report – Kaipapau Stream

Requirements of Chapter 104, HRS

Wages and Hours of Employees on Public Works Law

Federal Wage Rates

Proposal Title Page

ProposalP-1 – P-7
Proposal ScheduleP-8 – P-19

Disadvantaged Business Enterprise (DBE) Contract Goal Verification and Good Faith Efforts (GFE) Documentation For Construction

Disadvantaged Business Enterprise (DBE) Confirmation and Commitment Agreement – Trucking Company

Disadvantaged Business Enterprise (DBE) Confirmation and Commitment Agreement – Subcontractor, Manufacturer, or Supplier

Surety Bid Bond

Sample Forms

Contract

Performance Bond (Surety)

Performance Bond

Labor and Material Payment Bond (Surety)

Labor and Material Payment Bond

Disclosure of Lobbying Activities
Standard Form - LLL and LLL-A

Statement of Compliance
Form WH-348

Chapter 104, HRS Compliance Certificate

END OF TABLE OF CONTENTS

1 Amend **Section 511 - Drilled Shafts** to read as follows:
2
3

4 **“SECTION 511 - DRILLED SHAFTS**
5

6
7 **511.01 Description.** This section is for installing, drilling, reinforcing, concreting
8 and crosshole sonic logging of drilled shafts in the locations shown on the plans.
9

10 **511.02 Materials.** Materials shall conform to the following:
11

12 **(A) Portland Cement Concrete.** Concrete shall conform to Section 601 -
13 Structural Concrete and Section 511 – Drilled Shafts.
14

15 The in-place concrete shall have minimum 28-day compressive strength
16 $f'_c = 4500$ pounds per square inch and maximum water to cement ratio of 0.45
17 based on a maximum cementitious material content of 720 pounds per cubic
18 yard.
19

20 Proportion the concrete mix designs to get properties of high workability,
21 compaction under self-weight, resistance to segregation, and resistance to
22 excessive bleeding. The maximum nominal aggregate size shall be 0.375 inch.
23 The slump range shall be 7.0 inches \pm 1.0 inch for concrete poured into a water
24 free borehole and 8.0 inches \pm 1.0 inch for concrete placed under water or under
25 drilling slurry. Slump for the concrete shall be a minimum of four inches after four
26 hours from initial mixing or after the completion of the concrete placement,
27 whichever occurs later.
28

29 A migrating corrosion inhibiting amine carboxylate water-based admixture
30 shall be added to the concrete. The minimum dosage shall be 1.5 pints per cubic
31 yards of concrete.
32

33 The Engineer will permit superplasticizers.
34

35 At the time of placement, the concrete temperature shall not exceed 90°F.
36

37 The final concrete mix design shall be based on field trial batches to
38 determine the most suitable materials and proportions that will provide a concrete
39 mixture having the least amount of segregation and bleeding, and at the same
40 time provide the necessary workability to meet placing requirements.
41

42 **(B) Reinforcing Steel.** Reinforcing steel shall conform to Section 602 -
43 Reinforcing Steel.
44

45 **(C) Casings.** Casings shall have inside diameters not less than the
46 required diameter of the shafts and wall thicknesses specified or adequate to
47 withstand construction loads and stresses.
48

49 **(D) Cement Grout.** Cement grout used for setting the expandable load
50 cells and for filling the access tubes after completion of crosshole sonic logging
51 tests and cored holes, shall be prepackaged, non-shrink, and non-metallic grout.
52 The grout shall, at a minimum, have the same strength as the drilled shaft
53 concrete. The grout shall contain 10 grams of water-based migrating amine
54 carboxylate corrosion inhibitor per 0.5 cubic feet. Cement grout used to fill cored
55 holes shall be extended with 3/8 inch pea gravel per manufacturer's
56 recommendations.

57
58 **(E) Crosshole Sonic Logging (CSL) Test Access Tube.** Access tube
59 shall be at least 2-inch inside diameter, Standard steel pipe conforming to ASTM
60 A53, Grade B, Type E.

61
62 Access tube shall have round, regular inside diameter, free of defects and
63 obstructions, including all pipe joints, in order to permit free unobstructed
64 passage of 1.375-inch maximum diameter source and receiver probes used for
65 crosshole sonic logging testing. Access tube shall be watertight, free from
66 corrosion, with clean internal and external faces to ensure good bonding between
67 the drilled shaft concrete and access tubes. Fit access tubes with watertight
68 caps on bottom and top. Both ends of the access tube shall be capped at all
69 times except when being connected to another access tube. The end of the
70 tubes shall be undamaged and suitably prepared for the end caps and coupling
71 system adopted. Access tube coupling shall be used when extension of the
72 access tubes is necessary. The access tube coupling shall be watertight.

73
74 When crosshole sonic logging testing is indicated in the contract
75 documents, submit manufacturer's certificate of compliance for the acceptance of
76 the access tube.

77 78 **511.03 Construction**

79
80 **(A) Qualifications of Drilled Shaft Contractor.** Be capable of installing
81 drilled shafts, conducting load tests and other related work as specified in the
82 contract and shall have the following minimum experience requirements below.

83
84 **(1) Drilled Shaft Experience.** Because of the expertise required to
85 successfully complete the drilled shafts according to the contract, a
86 qualified drilled shaft Contractor shall install the drilled shaft. The drilled
87 shaft Contractor shall have installed at least three projects completed in
88 the last three years on which the Contractor has installed a minimum of
89 five drilled shafts per project of a diameter and length similar to those
90 shown in the contract. Include in list of projects, names and phone
91 numbers of owner's representatives who can verify the drilled shaft
92 contractor's participation on those projects. Drilled shaft Contractor shall
93 have on its payroll and on the project for the entire duration, supervisory
94 personnel who have participated in drilled shaft construction, similar to the
95 type proposed in the contract, for duration of at least three years within the
96 last 10 years.

98 **(B) Preconstruction Requirements.**

99
100 **(1) Experience Information.** Submit the following information to the
101 Engineer within 30 days after award of contract for acceptance by the
102 Engineer:

103
104 **(a)** List of drilled shaft projects completed in the past 10 years.
105 The list of projects shall contain the names and phone numbers of
106 owner's representatives who can verify participation on that project.

107
108 **(b)** Name and experience record of the drilled shaft
109 superintendent who will be in charge of drilled shaft operations for
110 this project. Drilled shaft superintendent shall have minimum three
111 years experience within the last 10 years in drilled shaft
112 construction similar to type proposed. Drilled shaft superintendent
113 shall remain on the project for the duration of the drilled shaft work.
114 Drilled shaft superintendent who leaves the project shall be
115 replaced with personnel with equal or better experience. Submit
116 proposed replacement superintendent's name and experience
117 record for acceptance.

118
119 **(2) Protection of Existing Structures.** Prevent damage to existing
120 structures and utilities. Preventive measures shall include:

121
122 **(a)** Selecting construction methods and procedures that will
123 prevent caving of the shaft excavation and

124
125 **(b)** Monitoring and controlling the vibrations from construction
126 activities such as the driving of casing or sheeting or drilling of the
127 shaft

128
129 **(3) Installation Plan.** At least 30 days before constructing the drilled
130 shafts, submit an installation plan for acceptance by the Engineer. This
131 plan shall at a minimum provide information on the following:

132
133 **(a)** List of proposed equipment such as cranes, drills, augers,
134 bailing buckets, final cleaning equipment, concrete pumps, and
135 casing,

136
137 **(b)** Details of construction operation sequence and the
138 sequence of shaft construction in bents or groups,

139
140 **(c)** Details of shaft excavation methods including how the
141 excavated material from the drilled shaft will be controlled on site
142 and removed; and method of setting and extracting temporary
143 casing,

144
145 **(d)** If the Contractor plans to use slurry, details of the methods
146 to mix, circulate and desand slurry,

147
148
149
150
151
152
153
154
155
156
157
158
159
160
161
162
163
164
165
166
167
168
169
170
171
172
173
174
175
176
177
178
179
180
181
182
183
184
185
186
187
188
189
190
191
192
193
194
195
196
197

(e) Details of methods to clean the shaft excavation, include the method that shall be used to determine that the bottom of the drilled shaft has been cleaned to contract document requirements

(f) Details of reinforcement placement including lifting, support, and centralization methods,

(g) Details of concrete placement including proposed operational procedures for pumping method,

(h) Details of attaching the crosshole sonic logging test access tubes to the reinforcing cage, details of testing access tubes for leakage after cage installation and prior to shaft concrete placement, and details for grout placement in the crosshole sonic logging test access tubes after testing is completed,

(i) Details of required load tests, including equipment, procedures, and recent calibrations for jacks or load cells supplied by the Contractor,

(j) Proposed concrete mix design, including expected strengths at 3,7, and 28 days. Submit test results of both a trial mix and a slump loss test, conducted by State-accepted accredited testing laboratory using methods specified in Section 601 - Structural Concrete. Tests shall demonstrate that concrete meets 4-hour plasticity requirement at expected ground ambient temperature and at highest expected ambient air temperature (two separate slump loss tests required), and

(k) Test results from laboratory measurements of the ultrasonic pulse velocity, performed in accordance with ASTM C 597, on 3-day, 7-day, and 28-day concrete trial mix samples described in Subsection 511.03(B)(3)(j).

The Engineer will evaluate the drilled shaft installation plan for conformance with the contract documents. Within 30 days after receipt of the plan, the Engineer will notify the Contractor of additional information required including if applicable, changes necessary to meet the contract requirements. The Engineer will reject parts of the installation plan that are unacceptable. The Contractor shall resubmit changes for re-evaluation within 15 days. The Engineer will have another 30 days to review all resubmittals. Procedural acceptance given by the Engineer shall be subject to trial in the field. The acceptance shall not relieve the Contractor of the responsibility to complete the work according to the contract.

(4) Trial Shaft Installation. Demonstrate adequacy of proposed methods and equipment by successfully constructing a trial shaft of the shaft diameter to be installed, in accordance with contract documents. The details of reinforcement shall be the same as for the production drilled

198 shafts. Position trial shaft away from production shafts, at location shown
199 in the contract documents, or as ordered by the Engineer. Drill trial shaft
200 to the depth shown on the contract documents.

201
202 CSL test access tubes shall be installed in the trial shaft as shown
203 on the contract to allow performance of CSL tests. Installation of the CSL
204 tubes shall be in accordance with Subsection 511.02(E) Crosshole Sonic
205 Logging (CSL) Test Access Tube and shall be incidental to the trial shaft
206 work.

207
208 The trial shaft shall be subject to integrity testing using concrete
209 coring to evaluate the effectiveness of the concrete placement method
210 proposed by the Contractor. Coring shall be conducted by the Contractor
211 in the presence of the Engineer. The Contractor shall core a vertical hole
212 throughout the full depth at two locations of the trial shaft determined by
213 the Engineer. Core specimens shall be a minimum diameter of 3.7 inches.
214 The Contractor shall submit the coring samples to the Engineer in core
215 boxes properly labeled with the core number and depths. Coring of the
216 trial shaft shall be incidental to the trial shaft work. The measured unit
217 weight of the air-dry core samples shall not be less than three pounds per
218 cubic foot of the air-dry unit weight test cylinders.

219
220 If the Engineer rejects trial shaft due to deviation from requirements
221 of the contract documents, alterations to proposed methods and
222 equipment may be required. The concrete mix design may also be altered
223 to meet the contract document requirements. Drill additional trial holes to
224 demonstrate adequacy of altered construction methods or equipment at
225 no increase in contract price or contract time. Once the Engineer has
226 accepted trial shaft and has authorized construction of production shafts,
227 do not deviate from accepted methods or equipment without the
228 Engineer's written approval.

229
230 Fill trial drilled shaft hole with concrete using the accepted
231 production drilled shaft concrete mix design, using method proposed for
232 production shaft construction. Cut the concreted trial shafts off 24 inches
233 below finished grade and leave in place. Restore disturbed areas at trial
234 shaft sites to original condition, unless otherwise specified.

235
236 **(5) Drilled Shaft Load Tests.** Load test shall be performed at the
237 location shown on the plans and be completed before construction of any
238 production drilled shafts. This work includes all labor, materials,
239 equipment and services necessary for conducting the bi-directional axial
240 load tests and reporting the results, including the following: (a) the
241 number of bi-directional expandable load cells as indicated on the plans,
242 (b) materials to construct a stable reference beam system(s) for
243 monitoring vertical and horizontal deflection of the drilled shaft during
244 testing, supported a minimum distance of the reference system, (c)
245 materials sufficient to construct and protect the work area, load test
246 equipment, and personnel from inclement weather and sunlight, and
247 illuminate area as needed, (d) electric power as required and suitable for

lights, welding, instruments, etc., working all at once and (e) suitable optical survey equipment to measure the horizontal and vertical displacement of shafts during tests independent of the reference beam(s) and electronic equipment.

(a) Experience Requirements. The Contractor shall obtain the services of an experienced specialty Subcontractor with a minimum of three years of bi-directional load testing experience accepted by the Engineer to direct the assembly and instrumentation of the load cells, and to record all data and furnish results of the test to the Engineer.

(b) Materials. Materials for the drilled shaft load test shaft shall conform to the requirements of Section 511.02 - Materials.

(c) Load Test Instrumentation. Provide instrumentation consisting of vibrating wire embedment strain gauges connected to a central data collection terminal; expandable load cell with readout device, and/or other equipment specified or indicated to measure movement of the top and bottom plates of the load cell, top of shafts, and strain at indicated locations within the shaft.

The embedment strain gauges shall be positioned along the test shaft at intervals shown on the Plans. The embedment strain gauges shall be attached securely to prevent movement from the installed location. The Engineer may require relocation of the embedment strain gauges and load cell based on the submittals provided by the Contractor. Each embedment strain gauge shall be capable of measuring strain to the nearest 0.0001 inch/inch and shall be capable of measuring or compensating for temperature. All embedment strain gauges shall have been calibrated or certified as accurate prior to installation. Take precautions not to damage the embedment strain gauges.

Load cell shall be a flat, hydraulically expandable load cell of a minimum of 26 inches in diameter and capable of applying a load test of at least 3,600 kips in each direction. The load cell shall be accurate to within 1%, shall expand uniformly, and shall be capable of being installed as described herein. The load cell shall have provisions for monitoring displacements of the upper and lower plates to an accuracy of 0.001 inch. The load cell shall have been calibrated or certified as accurate to within 1% of the true loads not more than six months prior to installation.

(d) Construction Requirement. The drilled shaft load test shall be a bi-directional load test utilizing a hydraulically expanded load cell. The bi-directional load test separately tests the shear resistance and end-bearing of the drilled shaft by loading the shaft in two directions (upward-shear resistance, downward-end bearing and shear resistance), using hydraulically expanded load cell, or by

298
299
300
301
302
303
304
305
306
307
308
309
310
311
312
313
314
315
316
317
318
319
320
321
322
323
324
325
326
327
328
329
330
331
332
333
334
335
336
337
338
339
340
341
342
343
344
345
346

loading the shaft using other accepted methods capable of full separation of the shear bearing components. The drilled shaft used for the load test program shall be instrumented, as specified in this Section, by an experienced specialty Subcontractor accepted by the Engineer. Load test shaft with excessive lateral extension (more than 12 inches) of the shaft diameter will be rejected, unless accepted by the Engineer. Rejected load test shaft shall be replaced at no additional cost to the State.

The Contractor shall supply equipment required to install the load cell, conduct the load test, and remove the load test apparatus as required. For the drilled shaft load test, the following set up procedure shall be used:

(1) The load cell, piping and other attachments will be assembled and made ready for installation under the direction of the specialty Subcontractor, in a suitable area, adjacent to the load test shaft, to be provided by the Contractor. The load cell assembly shall be placed at the location shown on the plans in conjunction with the construction of the reinforcing cage. The Engineer reserves the right to adjust the location of the load cell prior to installation.

(2) Advance the load test excavation to the maximum depth shown on the plans. A successfully completed trial shaft that is acceptable to the Engineer may not be used as the load test shaft.

(3) Clean the bottom of the shaft excavation after drilling is complete.

(4) Caliper testing shall be performed on the load test shaft to obtain profile shape data to be used to verify the shaft verticality and diameter. A minimum of eight data points around the circumference of the load test shaft shall be obtained at every one foot increment throughout the depth of the load test shaft. Caliper testing may be performed using a sonar-type caliper.

(5) Install the rebar cage assembly and load cell under the direction of the specialty Subcontractor and in the presence of the Engineer. The Contractor shall use the utmost care in handling the rebar cage/test equipment assembly so as not to damage the instrumentation during installation.

(6) After the installation of the rebar cage/test equipment assembly, the drilled shaft shall be concreted in the same

347 manner as accepted by the Engineer based on the trial shaft
348 installation and as specified for production shafts.

349
350 **(e) Load Test Schedule.** The Contractor shall notify the
351 Engineer of the load testing schedule a minimum of fifteen calendar
352 days prior to the commencement of load testing.

353
354 **(f) Load Test Procedures.** The load test shall be completed
355 and the load test data evaluated by the Engineer for revision to the
356 production shaft length before construction of any production
357 shafts. The Engineer shall have at least 21 calendar days after
358 submission of the load test report to review the load test result prior
359 to providing the production shaft lengths. Load testing on the
360 shaft shall not begin until the concrete has attained a compressive
361 strength of 4,000 psi and aged for seven days.

362
363 Load the load test shaft using the quick load test method of
364 ASTM D1143 except as modified herein. Apply the test load in
365 increments of 50 to 100 kips, as directed by the Engineer. A
366 load-deflection curve shall be plotted as the test progresses to
367 avoid missing information near the failure load or to correct the
368 precise load increments.

369
370 The load test shall be conducted to the maximum test load of
371 3,000 kips or plastic failure, whichever occurs first. Plastic failure
372 is defined as the load corresponding to mobilization of side shear or
373 end bearing and no further increase in load can be obtained.

374
375 The load test shall be held for a minimum of 4 hours each at
376 the 2,000, 2,500, and 3,000-kip load interval to evaluate the creep
377 effects, or at specific loads as directed by the Engineer.

378
379 **(g) Cleanup.** After completion of the load test, and at the
380 direction of the Engineer, the Contractor shall remove all
381 equipment, waste and other material that is not a part of the
382 finished structure. The load cell remaining in the shafts shall then
383 be grouted through the piping provided as a part of the load cell
384 assembly. Use non-shrink, non-metallic grout that at a minimum
385 has the same strength as the drilled shaft concrete.

386
387 After completing the test, cut off the load test shafts at an
388 elevation 24 inches below the finished ground surface. The
389 portion of the shafts cut off and removed shall remain the property
390 of the Contractor.

391
392 **(h) Replacement.** Load test shaft found inadequate because
393 of improper or failure of instrumentation, testing or construction
394 procedures shall be replaced and retested, at no additional cost to
395 the State.

396
397
398
399
400
401
402
403
404
405
406
407
408
409
410
411
412
413
414
415
416
417
418
419
420
421
422
423
424
425
426
427
428
429
430
431
432
433
434
435
436
437
438
439
440
441
442
443

(i) Reporting. Report the test results as specified in ASTM D1143-81 including, but not limited to, the following:

- (1)** Introduction;
- (2)** Drilled shaft installation procedure;
- (3)** Load test procedure and instrumentation; and
- (4)** Appendix which shall include report of calibration of instruments, plan view location of the load test and test boring related to the Project, records of subsurface exploration, records of load test shaft installation, tabular and graphical presentation of the load-deflection data of end-bearing and side shear from the load test.

(C) Construction Requirement. This subsection shall be applicable to trial, load test and production drilled shafts unless otherwise directed by the Engineer.

(1) Construction Sequence. Complete the excavation to footing elevations before shaft construction begins. Repair the disturbances caused by shaft installation to the footing area before pouring the footing.

When installing drilled shafts with embankment placement, construct drilled shafts after the placement of fills.

Do not cap the drilled shafts before placing the fills as near to final grade as possible. Only leave room for construction of the caps.

(2) Construction Methods. Excavate for shafts to the dimensions and elevations shown in the contract. Its methods and equipment shall be suitable for the intended purpose and materials met. Use the permanent casing method only when required by the contract or authorized by the Engineer. Blasting shall not be permitted.

(a) Dry Construction Method. The dry method includes drilling the shaft excavation, removing accumulated water and loose material from the excavation, and placing the reinforcing cage and shaft concrete in a dry excavation. Use this method only at sites where the groundwater table and soil conditions are suitable to permit construction of the shaft in a dry excavation. The Engineer will inspect the sides and bottom of the shaft visually before placing the concrete. Dry excavation is defined as an excavation where maximum depth of water does not exceed 3 inches.

444
445
446
447
448
449
450
451
452
453
454
455
456
457
458
459
460
461
462
463
464
465
466
467
468
469
470
471
472
473
474
475
476
477
478
479
480
481
482
483
484
485
486
487
488
489
490
491
492

(b) Wet Construction Method. This method includes using water, mineral, or polymer slurry to maintain stability of the hole perimeter while advancing the excavation to final depth, placing the reinforcing cage, and concreting the shaft. Use this method at sites where a dry excavation for placement of the shaft concrete cannot be maintained

Reuse drilling water only if permitted by the Engineer and contingent upon control of unit weight to no more than 62.5 pounds per cubic foot and Marsh funnel viscosity to not more than 27 seconds per quart, at the time drilling water is introduced into the borehole.

When locating drilled shafts in open water areas, extend the exterior casings from above the water elevation into the ground. Install the exterior casing to produce a positive seal at the bottom of the casing so that no intrusion or extrusion of water or other materials occurs into or from the shaft excavation.

(c) Casing Construction Method. The casing method may be used when shown in the contract or at sites where the dry or wet construction methods are inadequate. The casing may be placed either in a predrilled hole or advanced through the ground by twisting, driving, before cleaning the casing.

(3) Excavation.

(a) General. Make the shaft excavations at locations, and to shaft geometry and dimensions shown in the contract. After acceptance by the Engineer, adjust drilled shaft tip elevations when the material met during excavation is unsuitable and/or differs from that anticipated in the design of the drilled shaft.

Maintain a construction method log during shaft excavation. Submit method log within 24 hours of shaft drilling completion. The log shall contain information such as:

- (1)** Excavation diameters;
- (2)** Equipment used;
- (3)** Type of material excavated with the elevations of the material;
- (4)** Rate of excavation including time drilling started, when different material is encountered, tool changes, finish of shaft excavation, and difficulties encountered; include start, end time of obstruction encounters as well as type,

493
494
495
496
497
498
499
500
501
502
503
504
505
506
507
508
509
510
511
512
513
514
515
516
517
518
519
520
521
522
523
524
525
526
527
528
529
530
531
532
533
534
535
536
537
538
539
540

(5) The description of and approximate top and bottom elevation of each soil or rock material as well as type of obstruction, encountered.

(6) Elevation and approximate rate of any seepage or groundwater; and

(7) Remarks, including temporary stoppages

Drilling of shafts within a horizontal distance of 3.0 times the shaft diameter to the hole being drilled shall not commence until a minimum of 24 hours after the drilled shaft has been completed by placement of concrete to the top of shaft elevation in order to avoid interaction effects between adjacent shafts.

On projects with cofferdams, provide a qualified diver to inspect the cofferdam conditions when the contract requires a seal for construction. Before placing the concrete seal, the diver shall inspect the cofferdam interior periphery. The cofferdam interior periphery inspection includes each sheeting indentation and around each drilled shaft.

Furnish drilled shaft concrete required to fill excavations for shafts dimensioned in the contract documents.

Any drilled shaft concrete over the theoretical amount required to fill any excavations for the shafts dimensioned on the plans shall be furnished at no additional cost.

Dispose the excavated material according to Section 203 - Excavation and Embankment.

Do not permit workers to enter the shaft excavation unless:

(1) A suitable casing is in place.

(2) The water level is lowered and stabilized below the level the workers will occupy, and

(3) Adequate safety equipment and procedures are provided, performed and in place.

(b) Excavation and Drilling Equipment. The excavation and drilling equipment shall have adequate capacity including power, torque, and down thrust to excavate a hole to the maximum diameter and to a depth of ten feet or 20% beyond the depths shown in the contract, whichever is greater.

541 The use of special drilling equipment and/or procedures will
542 be necessary to drill through the cobbles and boulders. The
543 Contractor shall anticipate an abundance of boulders or various
544 sizes in deposits classified as "fill" and "older alluvium" on the
545 boring logs and shall make allowance for difficult drilling in his bid.
546 In addition, the Contractor shall make allowance for difficult drilling
547 in his bid within the basalt rock formation.
548

549 The excavation and overreaming tools shall be of adequate
550 design, size, and strength to do the work shown in the contract.
551

552 **(1) Special Drilling Equipment.** When conventional
553 earth augers and/or underreaming tools cannot be used for
554 drilling, provide special drilling equipment including rock core
555 barrels, rock tools, air tools and other equipment as
556 necessary to construct the shaft excavation to the size and
557 depth required. The use of special drilling equipment and/or
558 procedures will be necessary to drill through the cobbles and
559 boulders, and cost shall be incidental to unclassified shaft
560 excavation.
561

562 **(2) Sidewall Overreaming.** When the sidewall of the
563 hole has softened, swelled, or degraded, sidewall
564 overreaming will be required by the Engineer. Overreaming
565 thickness shall be a minimum of 0.5 inch and a maximum of
566 3.0 inches. The Contractor may overream with a grooving
567 tool or overreaming bucket. The thickness and elevation of
568 sidewall overreaming shall be according to the contract or as
569 directed by the Engineer. Overream sidewall and place
570 additional shaft concrete at no cost to the State.
571

572 **(c) Unclassified Excavation.** All excavation for the
573 production drilled shafts shall be designated as unclassified. The
574 Contractor shall anticipate the presence of cobbles and boulders
575 within the depths of the drilled shafts. The Contractor shall provide
576 the necessary equipment to remove and dispose of materials met
577 in forming the drilled shaft excavation, including installation of
578 temporary casing and/or use of slurry, as necessary. The Engineer
579 will not make separate payment for excavation of materials of
580 different densities and character (hardness) or employment of
581 special tools and procedures necessary to excavate. The Engineer
582 will pay for obstruction removal separately.
583

584 **(d) Obstructions Removal.** Remove obstructions at drilled
585 shafts locations when authorized by the Engineer. Obstructions
586 shall include man-made materials such as but not limited to old
587 concrete foundations not shown on the Plans.
588

589
590
591
592
593
594
595
596
597
598
599
600
601
602
603
604
605
606
607
608
609
610
611
612
613
614
615
616
617
618
619
620
621
622
623
624
625
626
627
628
629
630
631
632
633
634
635
636
637

The Contractor shall employ special procedures and/or tools after the Contractor cannot advance the hole using conventional augers fitted with soil or rock teeth, drilling buckets, core barrels and/or underreaming tools. Such special procedures/tools may include: chisels, boulder breakers, air tools, hand excavation, temporary casing, and increasing the hole diameter.

Drilling tools and any other equipment, lost in excavation, are not considered obstructions. Remove the drilling tools and any other equipment promptly. The cost due to tools lost in the excavation shall be at no additional cost to the State including costs associated with hole degradation (requiring overreaming or other methods) due to removal operations or the time the hole remains open or any other remedial actions needed to be performed to correct the situation caused by the tool lost.

Natural materials used as fill materials such as cobbles and boulders shall be anticipated at the site during excavation and shall not be considered an obstruction regardless of the size and hardness of the boulder. These natural materials used as fill materials shall not be considered an obstruction under this section.

(4) Casings.

(a) General. Casings shall be steel, smooth, watertight, and of ample strength to withstand both handling and driving stresses and the pressure of concrete and the surrounding earth materials. The inside diameter of the casing shall not be less than the specified size of the shaft. The Engineer will not allow extra compensation for concrete required to fill the oversized casing or oversized excavation. Remove casings from shaft excavations except when the casing is permanent. If the Contractor elects to pre-drill for the permanent casing, the pre-drilled hole diameter shall be no larger than the outside diameter of the permanent casing. The Contractor shall take proper measures and shall be responsible for maintaining the tip elevation of the permanent casing at the specified elevations.

When the shaft extends above ground or through a body of water, the shaft may be formed with removable casing except when the casing is permanent. Remove the casing carefully, where specified, so that the casing will not damage the cured concrete. When the casing needs to be removed after the concrete hardens in open water, design and submit the special system for acceptance by the Engineer. The Contractor may remove the casings only when the concrete attains sufficient strength provided:

- (1)** The curing of the concrete continues for the full 72 hour period,

638
639
640
641
642
643
644
645
646
647
648
649
650
651
652
653
654
655
656
657
658
659
660
661
662
663
664
665
666
667
668
669
670
671
672
673
674
675
676
677
678
679
680
681
682
683
684
685
686
687

(2) The shaft concrete is not exposed to salt water or moving water for a minimum of 7 days after placement, and

(3) The concrete reaches a compressive strength of at least 2,500 pounds per square inch.

(b) Temporary Casing. The Engineer will consider subsurface casing temporary unless shown in the contract as permanent casing. Remove the temporary casing before completing the placing of concrete in the drilled shaft. The Contractor may require telescoping, predrilling with slurry, and/or overreaming to beyond the outside diameter of the casing to install casing.

When choosing to remove a casing and substituting a longer or larger diameter casing through caving soils, stabilize the excavation with slurry or backfill before installing the new casing.

Before withdrawing the casing, the level of fresh concrete in the casing shall be the higher of the following:

(1) Minimum of five feet above the hydrostatic water level, or

(2) Level of drilling fluid, outside the casing.

While withdrawing the casing, maintain an adequate level of concrete within the casing to:

(1) Displace the fluid trapped behind the casing upward and

(2) Discharge the fluid at the ground surface without contaminating or displacing the shaft concrete.

When temporary casings become bound or fouled during shaft construction and cannot be removed, the Engineer will consider the drill shaft defective. Improve such defective shafts according to the contract or submit remedial repair for acceptance by the Engineer. Such improvement may consist of removing the shaft concrete and extending the shaft deeper, providing straddle shafts to compensate for capacity loss, or providing a replacement shaft. Do corrective measures including redesign of footings caused by defective shafts according to the contract at no cost to the State or extension of the contract time. Any redesign of the footing shall be submitted to the Engineer for acceptance. The redesign shall be performed by a structural engineer and a civil engineer specializing in the geotechnical practice both licensed in the State of Hawaii. All remedial repairs shall have drawings and

688 calculations signed and stamped by both of the above licensed
689 engineers. The Engineer will not pay for the casing remaining in
690 place as well as any redesign or remedial repair.

691
692 **(5) Slurry.** If required, use only polymer slurry in the drilling process.
693 The polymer slurry shall have sufficient viscosity and gel characteristics to
694 transport excavated material to suitable screening system. The
695 percentage and specific gravity shall be sufficient to maintain the stability
696 of the excavation and to allow proper concrete placement.

697
698 During construction, maintain the level of the slurry at a height
699 sufficient to prevent caving of the hole. When a sudden significant loss of
700 slurry occurs, delay the construction of that foundation until an alternate
701 construction procedure is submitted for acceptance by the Engineer.

702
703 Premix the polymer slurry thoroughly with clean fresh water in
704 slurry tanks and adequate time (as prescribed by the manufacturer)
705 allotted for dehydration before introducing the slurry by pumping into the
706 shaft excavation. The slurry tanks shall have capacity for adequate slurry
707 circulation, storage, and treatment. Excavated slurry pits in lieu of slurry
708 tanks will not be allowed without the written permission of the Engineer.

709
710 Use desanding equipment to control slurry sand content to less
711 than 0.5% by volume in the borehole for polymer slurry. The Engineer will
712 not require desanding equipment for setting temporary casing, sign post,
713 or lighting mast foundations.

714
715 Prevent the slurry from "setting up" in the shaft, such as: agitation,
716 circulation and/or adjusting the properties of the slurry. Dispose of slurry
717 in suitable areas off from the project site.

718
719 The Contractor shall have the representative from the manufacturer
720 of the slurry product on site providing the technical support for the slurry
721 preparation, placement, testing and other quality control. Also, make
722 adjustment as needed to slurry due to difference in ambient temperature
723 from the tables. Carry out the control tests using suitable apparatus on
724 the polymer or mineral slurry to resolve the density, viscosity, pH, and
725 sand content. Acceptable range of values for those physical properties for
726 two types of polymer slurries is in Tables 511-1 – Shore Pac GVC
727 (CETCO Drilling Products Group) IN FRESH WATER and 511-2 –
728 SLURRYPRO CDP (KB Technologies Ltd.) IN FRESH WATER.

729
730 Test the density, viscosity, and pH value during the shafts
731 excavation to establish a consistent working pattern. Make a minimum of
732 four sets of tests during the first 8 hours of slurry use. When the results
733 show consistent behavior, decrease the testing frequency to one set every
734 four hours of slurry use.

735

TABLE 511-1 - Shore Pac GCV (CETCO Drilling Products Group) IN FRESH WATER			
Property	Range of Values *		Test Method
	Time of Slurry Introduction	In Hole At Time Of Concreting	
Density (pcf)	Less than or equal to 64.0**	Less than or equal to 64.0**	Density Balance
Viscosity (sec/qt)	33 - 74	Less than or equal to 57	Marsh Cone
PH	8.0 – 11.0	8.0 – 11.0	pH paper pH meter
<p>* At 20^o C(68 degrees F)</p> <p>** Increase by two pounds per cubic foot in salt water</p> <p>Notes: a. When the Contractor does not need to control the bottom hole conditions or when tests show that other criteria are appropriate, the Engineer may modify the values.</p> <p>b. When the contract requires desanding, the sand content shall not exceed 0.5% percent (by volume) in the bore hole as resolved by the American Petroleum Institute sand content test.</p> <p>c. Submit changes for acceptance in writing by the Engineer.</p> <p>d. Increases in the viscosity of polymer slurry beyond the above acceptable ranges during drilling may be allowed by the Engineer. However, increases in the viscosity of the polymer slurry beyond the above acceptable ranges during concrete placement will not be allowed. Use of other polymer materials that increase the cohesion of the soil material, or other construction methods to reduce the slurry viscosity just prior to concrete placement may be considered in-lieu of increasing the viscosity of the slurry.</p>			

741
742
743
744

TABLE 511-2 - SLURRYPRO CDP (KB Technologies Ltd.) IN FRESH WATER			
Property	Range of Values *		Test Method
	Time of Slurry Introduction	In Hole At Time Of Concreting	
Density (pcf)	Less than or equal to 67.0**	Less than or equal to 64.0**	Density Balance
Viscosity (sec/qt)	50 - 120	Less than or equal to 70	Marsh Cone
PH	6.0 – 11.5	6.0 – 11.5	pH paper pH meter

* At 20^o C (68 degrees F)
** Increase by two pounds per cubic foot in salt water

Notes: a. When the Contractor does not need to control the bottom hole conditions or when tests show that other criteria are appropriate, the Engineer may modify the values.

b. When the contract requires desanding, the sand content shall not exceed 0.5% percent (by volume) in the bore hole as resolved by the American Petroleum Institute sand content test.

c. Submit changes for acceptance in writing by the Engineer.

d. Increases in the viscosity of polymer slurry beyond the above acceptable ranges during drilling may be allowed by the Engineer. However, increases in the viscosity of the polymer slurry beyond the above acceptable ranges during concrete placement will not be allowed. Use of other polymer materials that increase the cohesion of the soil material, or other construction methods to reduce the slurry viscosity just prior to concrete placement may be considered in-lieu of increasing the viscosity of the slurry.

745
746
747
748
749
750
751
752

Before placing concrete in the shaft excavation, take slurry samples from the base of the shaft using a sampling tool. Extract slurry samples from the base of the shaft and at intervals not exceeding 10 feet up the shaft. Extract samples until two consecutive samples produce acceptable values for density, viscosity, pH, and sand content (within the values shown on Table 511-1 - Shore Pac GCV (CETCO Drilling Products Group))

753 IN FRESH WATER or 511-2 - SLURRYPRO CDP (KB Technologies Ltd.)
754 IN FRESH WATER.
755

756 Ensure that the bottom of the shaft does not accumulate heavily
757 contaminated slurry suspension. The heavily contaminated slurry
758 suspension could impair the free flow of concrete. When finding
759 unacceptable slurry samples, take actions necessary to bring the slurry as
760 specified in the contract. Do not pour the concrete until re-sampling and
761 testing results produce acceptable values.
762

763 Furnish the reports of tests required above to the Engineer on
764 completion of each drilled shaft. An authorized person of the Contractor
765 shall sign the reports.
766

767 During construction, maintain at the level of slurry not less than five
768 feet above the highest piezometric water pressure along the depth of a
769 shaft. When the slurry construction method fails, stop this method and
770 propose an alternate method for acceptance by the Engineer
771

772 The Contractor shall use and dispose of slurry in accordance with
773 applicable Federal, State, and County requirements.
774

775 **(6) Excavation Inspection.** Provide equipment for checking the
776 dimensions and alignment of each permanent shaft excavation.
777 Determine the dimensions and alignment according to the contract.
778 Measure the final shaft depths with a suitable weighted tape after final
779 cleaning.
780

781 A minimum of 50% of the base of each shaft shall have less than
782 0.5 inch of sediment at the time the concrete is placed. The maximum
783 depth of sediment or debris on the base of the shaft shall not exceed 1.5
784 inches. The Contractor will measure the shaft cleanliness in the presence
785 of the Engineer by methods deemed appropriate to the Engineer.
786

787 Also, for dry excavations the maximum depth of water shall not
788 exceed 3 inches before pouring the concrete.
789

790 **(7) Reinforcing Steel Cage Construction and Placement.**
791 Assemble and place the reinforcing steel cage immediately after the
792 Engineer inspects and accepts the shaft excavation before pouring the
793 concrete. To prevent deformation of the cage and CSL test access tubes
794 while lifting, brace the reinforcing steel cage and CSL test access tubes
795 until the cage is set in it's final position. The reinforcing steel cage
796 includes longitudinal bars, ties, cage stiffener bars, spacers, centralizers,
797 and other necessary appurtenances to acceptably complete and place the
798 cage.
799

800 Tie and support the reinforcing steel in the shaft so that the reinforcing
801 steel will remain within allowable tolerances given in Subsection

802 511.03(C)(10) – Construction Tolerances. Use the concrete spacers or
803 other approved non-corrosive spacing devices at sufficient intervals (near
804 the bottom and at intervals not exceeding 10 feet up the shaft) to insure
805 concentric spacing for the entire cage length. Use minimum of four
806 spacers, equally spaced around circumference, at each vertical interval.
807 The spacers shall be constructed of accepted material equal in quality and
808 durability to concrete specified for the shaft, and shall be of adequate
809 dimension to insure a minimum of four inches annular space between the
810 outer portion of the reinforcing steel cage and the side of the excavated
811 hole. Provide accepted cylindrical concrete bottom supports to maintain
812 the proper distance between bottom of the cage and base of the shaft
813 excavation. Securely attach CSL test access tubes to reinforcing steel
814 cage so that it maintains during reinforcing steel cage placement. Check
815 CSL test access tubes that they are straight and its proper location add
816 additional devices to assure that the VSL test access tubes will remain in
817 the required location and alignment during the pouring of the drilled shaft
818 concrete.

819
820 Check the elevation of the top of the steel reinforcing cage and center of
821 cage location before, during and after pouring the concrete. When not
822 maintaining the rebar within the specified tolerances, make the corrections
823 needed to bring to within tolerances of the contract. Do not construct
824 additional shafts until after modifying the reinforcing steel cage support
825 according to the contract.
826

827 When the excavation at the bottom of the constructed shaft elevation is
828 lower than shown in the contract, extend at least half of the longitudinal
829 bars required in the upper portion of the shaft the additional length.
830 Continue the tie bars for the extra depth, spaced two-foot on center
831 measured along the circumference of the reinforcing steel cage. Extend
832 the stiffener bars to the final depth. These bars may be lap spliced or
833 unspliced bars of the proper length. The Engineer will not permit welding
834 to the reinforcing steel. Unless the extra depth of the drilled shaft is
835 required due to modifications by the Engineer, the additional reinforcing
836 bars shall be at no additional cost to the State.
837

838 **(8) Crosshole Sonic Logging (CSL) Test Access Tubes.**
839 Installation of access tubes shall be in accordance with ASTM Standard
840 Test Method for Integrity Testing of Concrete Deep Foundations by
841 Ultrasonic Crosshole Testing Designation D 6760, except as modified
842 herein. Install access tubes in all drilled shafts to allow performance of
843 CSL tests. Attach CSL access tubes securely to the interior of the
844 reinforcement cage as near to parallel as possible to the vertical center
845 axis of the drilled shaft in each drilled shaft and in the pattern shown on
846 the plans. Extend the access tubes from the bottom of the reinforcement
847 cage to at least 3.5 feet above the top of the shaft. The bottom of the
848 access tube shall be capped permanently. Joints required to achieve full
849 length of access tubes shall be watertight. Contractor shall take extra
850 care to prevent damaging the access tubes during reinforcement cage

851 installation. Fill the tubes with potable water to the top of the tubes as
852 soon as the reinforcing steel cage is installed. Check for leakage,
853 misalignment, and damage before placing concrete in the drilled shaft.
854 Stop all leaks if present and repair any damages or misalignment before
855 placement of concrete starts. Check water level as soon as possible after
856 concrete placement (within 4 hours after concrete placement) and fill with
857 potable water if needed. Check water level in tubes every day until CSL
858 testing is completed. Top off tubes with potable water if needed. Always
859 reinstall the top watertight caps. Installation of CSL access tubes shall be
860 incidental to the construction of the drilled shaft and shall be at no
861 additional cost to the State.

862
863 The completed drilled shaft foundations will be tested by crosshole
864 sonic logging (CSL) after at least five days of curing time, but no later than
865 20 days after concreting. The CSL test will be performed by the Engineer.
866 The Contractor shall assist in the testing by making all the shafts in the
867 project accessible to the Engineer; provide electricity, lights and other
868 needs whenever requested by the Engineer. Assistance by the
869 Contractor shall be incidental to the construction of the drilled shaft and
870 shall be at no additional cost to the State. The Contractor shall provide
871 accurate data on the dates and time of concrete placement for each drilled
872 shaft and the surveyed location of each tube. Also, provide the elevation
873 of the concrete at the top of the drilled shaft. The Engineer will require a
874 minimum of 20-working days after testing of any drilled shaft to accept or
875 reject that shaft.

876
877 The results of the CSL tests will be based on the percentage
878 decrease in velocity as correlated to the following Concrete Condition
879 Rating Criteria (CCRC), as shown in Table 511-3 – Concrete Condition
880 Rating Criteria. Deviations from the following values shall be used for
881 determining the Concrete Condition Rating.

882

Table 511-3 Concrete Condition Rating Criteria			
Concrete Condition Rating	Rating Symbol	Velocity Reduction	Indicative Results
Good	G	0 – 10%	Acceptable concrete
Questionable	Q	10% - 25%	Minor concrete contamination or intrusion. Questionable quality concrete.
Poor	P/D	> 25%	Defects exist, possible water slurry contamination, soil intrusion, and or poor quality concrete.
Water	W	V=4760 – 5005 feet/sec	Water intrusion or water filled gravel intrusion with few or no fines present.
No Signal	NS	No signal received	Soil intrusion or other severe defect absorbed the signal, tube debonding if near top.

884
885
886
887
888
889
890
891
892
893
894
895
896
897
898
899
900
901
902
903
904
905
906
907

Shafts with test results other than “Good” will be tested in accordance with Subsection 511.03(C)(12), Integrity Testing.

After completion of the crosshole sonic logging tests and final acceptance of the drilled shaft, all the access tubes shall be completely filled using a tremie method of placement. Access tubes shall be free of debris and water before filling with grout. Use non-shrink, non-metallic grout that at a minimum has the same strength as the drilled shaft concrete. Filling the access tubes shall be at no additional cost to the State.

(9) Concrete Placement.

(a) General. Place the concrete through a concrete pump or other means as accepted by the Engineer using accepted methods as described below.

Concrete shall be placed in the shaft immediately after placing the reinforcing steel.

Concrete placement for the load test drilled shaft shall be continuous from the bottom to at least the top of shaft cutoff elevation and until good quality concrete emerges above the top of

908
909
910
911
912
913
914
915
916
917
918
919
920
921
922
923
924
925
926
927
928
929
930
931
932
933
934
935
936
937
938
939
940
941
942
943
944
945
946
947
948
949
950
951
952
953
954
955
956

the shaft cutoff elevation. To ensure that the drilled shaft concrete is sound below the top of shaft cutoff elevation, the trial and production drilled shafts shall be poured at least four feet above the cutoff elevation and until good quality concrete is evident at least four feet above top of shaft cutoff elevation. The start of the removal of concrete above the cutoff elevation shall begin no sooner than 12 hours after the completion of the production drilled shafts concrete pour. For the trial drilled shafts, the concrete above the cutoff elevation shall be removed after the coring is completed. Prior to removing the concrete above the cutoff elevation, a circumferential diamond blade sawcut 2 ½ inches deep shall be made at the cutoff elevation. Then the portion of the drilled shaft more than one foot above the cutoff elevation shall be removed with equipment no larger than a 90-pound pavement breaker. Thereafter the remaining one foot of the drilled shaft above the cutoff elevation shall be removed using demo hammers no heavier than 30 pounds for the upper nine inches and 15 pound maximum for the lowest three inches, i.e., three-inches above the cutoff elevation. Hydro wash the demoed surface with a minimum of 2500 psi before pouring concrete.

A minimum of four and two, 6-inch by 12-inch concrete cylinders shall be made for the compressive strength testing and unit weight testing, respectively. Production shafts with compressive strength less than the minimum 28-day compression strength will be considered defective. Production shafts with air-dry core sample unit weight less than three pounds per cubic foot of the air-dry unit weight test cylinders will be considered defective. Contractor shall submit a corrective method plan for the defective shaft to the Engineer for review and approval prior to their use.

The elapsed time from the beginning of concrete placement in the shaft to the completion of the placement shall not exceed two hours. Adjust admixtures accepted by the Engineer so that concrete remains in a workable plastic state throughout 2-hour placement limit. A longer placement time may be requested, and requests shall be submitted to the Engineer for review and acceptance 30 days prior to the time the concrete pour (with a longer placement time) is needed. Should the Contractor exceed the 2-hour limit without obtaining prior acceptance by the Engineer, the Contractor may be required to core the drilled shaft. These drilled shaft corings shall be at no additional cost to the State and no additional time will be granted.

Before placing the concrete, provide results of 3-day, 7-day, 14-day and 28-day compressive strength tests of a trial mix and a slump loss test at least 30 days prior to placement of concrete. Supply a concrete mix that will maintain a slump of four inches or greater after four hours from initial mixing. Conduct the trial mix and

957 slump loss tests using concrete and under ambient temperatures
958 appropriate for the site conditions. The ambient temperature used
959 shall be the temperature at the elevation of existing ground before
960 any excavation started.

961
962 The top surface of the drilled shafts shall be leveled and
963 roughened. Hydro wash the roughen surface with a minimum of
964 2500 psi prior to concrete placement for the footing.
965

966 **(b) Monitoring Concrete Volume.** For each drilled shaft,
967 prepare and submit a monitoring record the next working day after
968 concrete placement has been completed. All monitoring shall be
969 performed in the presence of the Engineer or his representative. As
970 a minimum, the monitoring record shall consist of the following:
971

972 **(1)** A chart that is made up after drilled shaft excavation
973 has been completed and accepted by the Engineer and
974 before concrete placement has commenced. Indicated on
975 the chart, depth of hole plotted with theoretical volume of
976 concrete to fill drilled shaft hole. Plot concrete elevation
977 (surface) along the vertical axis and concrete volume along
978 the horizontal axis.
979

980 **(2)** As concrete is being place, measure concrete surface
981 at an interval of approximately each cubic yard of concrete
982 discharged. Plot concrete volume actually placed at each
983 elevation point. Use this chart to determine if any necking
984 down or enlargement of shaft has occurred during concrete
985 placement.
986

987 **(3)** Keep records of steel and concrete movement to
988 document the following conditions:
989

990 **(a)** When removing temporary or permanent
991 casing, elevation of the top of reinforcing cage shall
992 not rise more than 2 inches from its original elevation;
993

994 **(b)** As temporary casing is extracted, static level of
995 fluid concrete shall not rise.
996

997 **(c) Concreting by Pump.** Concrete pumps and discharge
998 lines for concrete placement in wet or dry excavations shall be
999 used. Pumps and pump lines used to place concrete shall be of
1000 sufficient length, weight, and diameter to discharge concrete at the
1001 shaft base elevation. The pump and pump lines that will come in
1002 contact with concrete shall not contain aluminum parts. Discharge
1003 line shall have a minimum diameter of 4 inches and watertight
1004 joints. Concrete placement shall not begin until the pump line
1005 discharge orifice is at the shaft base elevation.

1006
1007
1008
1009
1010
1011
1012
1013
1014
1015
1016
1017
1018
1019
1020
1021
1022
1023
1024
1025
1026
1027
1028
1029
1030
1031
1032
1033
1034
1035
1036
1037
1038
1039
1040
1041
1042
1043
1044
1045
1046
1047
1048
1049
1050
1051
1052
1053
1054

For wet excavations, use a plug to separate the concrete from the fluid in the hole until pumping begins. Remove the plug from the excavation or use plugs, made from a material accepted by the Engineer that will not cause a defect, if not removed.

The discharge orifice shall remain at least five feet below the surface of the fluid concrete. When lifting the pump line during concreting, reduce the line pressure temporarily until the orifice at a higher level in the excavation has been repositioned.

Upon removal of the pumpline orifice from the fluid concrete column and/or discharging concrete above the rising concrete level during the concrete pour, the Engineer will consider the shaft defective. In such a case, remove the reinforcing cage and concrete, the necessary sidewall removal specified by the Engineer, and repour the shaft. Costs of replacement of defective shafts shall be at no costs to the State and no additional time will be granted.

(10) Construction Tolerances. The following construction tolerances apply to drilled shafts:

(a) The center of the drilled shaft concrete and reinforcing bars shall be within 1/12 of the shaft diameter or 3 inches, whichever is less, in the horizontal plane at the plan elevation for the top of the shaft.

(b) The vertical alignment of the shaft excavation shall not vary from the plan alignment by more than 0.25 inch per foot of depth. The alignment of a battered shaft excavation shall not vary by more than 0.5 inch per foot of depth from the prescribed batter.

(c) After placing the concrete, the top of the reinforcing steel cage shall be no more than 6.0 inches above and no more than 3.0 inches below plan position.

(d) The cutoff (top) elevation of the shaft shall have a tolerance of ± 0.5 inch from the plan top of shaft elevation.

(e) The dimensions of casing are subject to American Pipe Institute tolerances applicable to regular steel pipe.

(f) Design the excavation equipment and methods so that the completed shaft excavation will have a flat bottom. The cutting edges of excavation equipment shall be normal to the vertical axis of the equipment within a tolerance of $\pm 3/8$ inch per foot of diameter.

1055 (g) Casing diameters shown in the contract documents to
1056 outside diameter (OD) dimensions. When accepted by the
1057 Engineer, a casing larger in diameter than shown in the contract
1058 documents may be provided to facilitate meeting this requirement.
1059 When using a series of telescoping casings, size casing to maintain
1060 shaft diameters.

1061
1062 Drilled shaft excavations that cannot be completed within the
1063 required tolerances are unacceptable. When accepted by the Engineer,
1064 corrections may be made to an unacceptable drilled shaft excavation by
1065 accepted combination of the following methods:

1066
1067 (a) Overdrill the shaft excavation to a larger diameter to permit
1068 accurate placement of the reinforcing steel cage with the required
1069 minimum concrete cover.

1070
1071 (b) Increase the number, size, or length of the reinforcing steel.

1072
1073 (c) Redesign the foundation.

1074
1075 (d) Other methods accepted by the Engineer.

1076
1077 The acceptance of correction procedures is dependent on
1078 analysis of the effect of the degree of misalignment and improper
1079 positioning. The Contractor is solely responsible to submit remedial
1080 repair procedures that shall make the structure equal to or better
1081 than the original design. The Engineer will solely determine if the
1082 remedial repair meets the requirements and is acceptable. A
1083 Hawaii Licensed Professional Structural Engineer and a Hawaii
1084 Licensed Professional Civil Engineer who specializes in
1085 Geotechnical Engineering shall stamp and sign the redesign
1086 drawings and computations. Correct out of tolerance drilled shaft
1087 excavations including engineering analysis and redesign at no cost
1088 to the State. No time extension will be granted for any impact to
1089 the critical path due to the Contractor's incorrect installation of the
1090 drilled shaft.

1091
1092 **(11) As-Built Drilled Shaft Location.** The Contractor shall provide
1093 survey ties to all as-built location of all drilled shafts. All survey work shall
1094 be done by a surveyor licensed in the State of Hawaii.

1095
1096 The Contractor shall notify the Engineer prior to performing the
1097 survey work and the Contractor shall survey the drilled shafts under the
1098 supervision of the Engineer or the Engineer's representative. A copy of the
1099 survey notes and the scaled plan locating all the completed drilled shafts
1100 for each footing shall be submitted to the Engineer for review and
1101 acceptance. The submittal shall be stamped and signed by the Hawaii
1102 licensed surveyor who did the work. Submit accepted copy of the survey

1103 notes and the scaled plan as an electronic file, the Engineer will determine
1104 the acceptable format and media.

1105
1106 No form work for any footing shall proceed until the drilled shafts
1107 are found acceptable by the Engineer.

1108
1109 **(12) Integrity Testing.** Drilled shafts shall be visually inspected and
1110 tested for density, strength and soundness. Integrity testing will be
1111 performed on drilled shafts as determined by the Engineer. Integrity
1112 testing shall consist of partial or full depth concrete coring at drilled shafts
1113 determined by the Engineer. Coring shall be performed by the Contractor
1114 at the locations designated by the Engineer in the presence of the
1115 Engineer. The Engineer will solely determine if the cored shaft is
1116 acceptable or defective. Defective shafts shall be replaced or repair using
1117 engineer accepted drawings and computations by a Hawaii Licensed Civil
1118 Engineer specializing in Geotechnical Engineering and Structural
1119 Engineer currently licensed in the State of Hawaii, and it shall bear their
1120 stamps and signatures. The Contractor shall core vertical holes at
1121 locations and depths determined by the Engineer. The number of core
1122 holes to be done shall be determined by the Engineer. The core hole shall
1123 be accepted by the Engineer. The recovered core samples shall have a
1124 minimum diameter of 3.7 inches or 3 times the nominal maximum
1125 aggregate size of the concrete mix, use whichever is larger

1126
1127 Provide concrete cores properly marked in a core box with labels of
1128 the drilled depth at each interval of core recovery to the Engineer for
1129 evaluation and testing. The Engineer will be allowed a minimum of 7
1130 working days for evaluation and testing of the core samples. The cored
1131 holes shall be filled with prepackaged, non-shrink, non-metallic grout that
1132 at a minimum has the same strength as the drilled shaft concrete.

1133
1134 Cost of coring performed on acceptable production drilled shafts
1135 with no defects will be borne by the State. Cost of full depth coring of trial
1136 shaft shall be borne by the Contractor. Cost of coring performed on any
1137 drilled shaft that has defects shall be borne by the Contractor. If the drilled
1138 shaft in question is on the critical path, a time extension and the linear foot
1139 payment for coring will be the sole remedy given if the drilled shaft has no
1140 defects. The delay will be calculated from the end of the 20 working days
1141 review period of the cores to when the last core was taken. Contractor
1142 shall submit a corrective methods plan for the defective shafts to the
1143 Engineer for review and approval prior to their use. The corrective
1144 methods plan shall restore the defective drilled shaft to a condition equal
1145 or better that of a drilled shaft that had no defects. Do not begin repair
1146 operations until receiving the Engineer's acceptance of the corrective
1147 methods plan for that defective drilled shaft.

1148
1149 **511.04 Measurement.**
1150

1151 (A) Furnishing drilled shaft drilling equipment and furnishing instrumentation
1152 and collecting data will be paid on a lump sum basis. Measurement for payment
1153 will not apply.

1154
1155 (B) The Engineer will measure obstruction per hour in accordance with the
1156 contract documents. Once the Engineer authorizes compensation for obstruction
1157 removal, duration of obstruction removal, including time required for obstruction
1158 disposal, will be measured for payment. Depth of obstruction removed will be
1159 subtracted from total depth measured for payment under other applicable drilled
1160 shaft excavation pay items.

1161
1162 (C) The Engineer will measure load test per each in accordance with the
1163 contract documents.

1164
1165 (D) The Engineer will measure trial shaft per linear foot. The Engineer will
1166 compute length between existing ground surface elevation at trial shaft hole
1167 center, before drilling, and authorized bottom elevation of hole.

1168
1169 (E) The Engineer will measure unclassified shaft excavation per linear foot,
1170 along shaft centerline, including bells. The Engineer will compute length
1171 between plan top of shaft elevation to plan estimated tip elevation.

1172
1173 (F) The Engineer will measure drilled shaft per linear foot. The Engineer will
1174 compute length between plan top of shaft elevation and to plan estimated tip
1175 elevation.

1176
1177 (G) The Engineer will measure coring for integrity testing per linear foot. The
1178 Engineer will compute length between the bottom of coring elevation and the top
1179 of the shaft concrete elevation.

1180
1181 **511.05 Payment.** The Engineer will pay for the accepted pay items listed below
1182 at the contract price per pay unit, as shown in the proposal schedule. Payment will be
1183 full compensation for the work prescribed in this section and the contract documents.

1184
1185 The Engineer will pay for each of the following pay items when included in the
1186 proposal schedule.

1187 Pay Item	1188 Pay Unit
1189	
1190 Furnishing Drilled Shaft Drilling Equipment	Lump Sum

1191
1192 The Engineer will pay for:

1193
1194 (A) 60 percent of the contract bid price when drilling equipment is on job site,
1195 assembled, and ready to drill foundation shafts.

1196
1197 (B) 40 percent of the contract bid price upon completion of drilling shafts, and
1198 placing shaft concrete up to top of shafts.

1199

1200	Obstructions	Hour
1201		
1202	The Engineer will pay for:	
1203		
1204	(A) 80 percent of the contract bid price upon completion of removing the	
1205	obstruction.	
1206		
1207	(B) 20 percent of the contract bid price upon removing and disposing of the	
1208	obstruction.	
1209		
1210	The maximum payment per designated obstruction shall not exceed 20	
1211	times the unit cost for unclassified excavation.	
1212		
1213	Load Test	Each
1214		
1215	The Engineer will pay for:	
1216		
1217	(A) 100 percent of the contract bid price upon completion of load test shaft	
1218	installation/construction and testing, and other related costs to the performance	
1219	of the load test.	
1220		
1221	Trial Shaft	Linear Foot
1222		
1223	The Engineer will pay for:	
1224		
1225	(A) 60 percent of the contract bid price upon completion of excavation trial	
1226	shaft holes through to bottom of shaft elevation or as authorized by the Engineer	
1227	and providing inspection facilities.	
1228		
1229	(B) 20 percent of the contract bid price upon completion of backfilling hole.	
1230		
1231	(C) 20 percent of the contract bid price upon completion of CSL testing and	
1232	restoring the site.	
1233		
1234	The Engineer will not pay for trial shaft holes that the Contractor failed to	
1235	demonstrate to the Engineer the adequacy of its proposed methods and	
1236	equipment.	
1237		
1238	Unclassified Shaft Excavation (_____)	Linear Foot
1239		
1240	The Engineer will pay for:	
1241		
1242	(A) 60 percent of the contract bid price upon completion of using drilling	
1243	equipment, using special tools and drilling equipment to excavated shaft.	
1244		
1245	(B) 20 percent of the contract bid price upon completion of furnishing and	
1246	installing temporary casing.	
1247		

1248 (C) 20 percent of the contract bid price upon completion of removing and
1249 disposing of excavated material.

1250
1251 Drilled Shaft (_____) Linear Foot

1252
1253 The Engineer will pay for:

1254 (A) 60 percent of the contract bid price upon completion of drilling.

1255
1256 (B) 15 percent of the contract bid price upon completion of furnishing,
1257 assembling, and placing steel cage.

1258
1259 (C) 15 percent of the contract bid price upon completion of furnishing and
1260 placing concrete.

1261
1262 (D) 10 percent of the contract bid price upon completion of removing and
1263 disposing of excavated material.

1264
1265
1266 Coring for Integrity Testing for acceptable drilled shaft. Linear Foot

1267
1268 The Engineer will pay for:

1269 (A) 70 percent of the contract bid price upon completion of concrete coring.

1270
1271 (B) 20 percent of the contract bid price upon completion of filling cored holes
1272 with non-shrink grout of the same minimum strength as drilled shaft.

1273
1274 (C) 10 percent of the contract bid price upon completion of packaging the core
1275 samples and delivering them to the Engineer.”

1276

1277

1278

1279

END OF SECTION 511

1 **SECTION 632 – MARKERS**

2
3 Make the following amendment to said Section:

4
5 **(I) Amend Section 632.04 - Measurement** by replacing lines 79 to 81 to read:

6
7 **“632.04 Measurement.** The Engineer will measure object marker with post
8 per each as complete units of the type and design specified in the proposal.”

9
10 **(II) Amend Section 632.05 – Payment** by replacing lines 83 to 100 to read:

11
12 **“632.05 Payment.** The Engineer will pay for object marker with post at the
13 contract price per each for the type and design specified complete in place.
14 Payment will be full compensation for excavating and backfilling, furnishing and
15 installing materials, furnishing equipment, tools, labors and incidentals necessary
16 to complete the work.

17
18 The Engineer will pay for the following pay items when included in the
19 proposal schedule:

Pay Item	Pay Unit
Type _____ Object Marker with Post	Each”

20
21
22
23
24
25
26
27
28 **END OF SECTION 632**
29

"General Decision Number: HI20210001 07/02/2021

Superseded General Decision Number: HI20200001

State: Hawaii

Construction Types: Building, Heavy (Heavy and Dredging), Highway and Residential

Counties: Hawaii Statewide.

BUILDING CONSTRUCTION PROJECTS; RESIDENTIAL CONSTRUCTION PROJECTS (consisting of single family homes and apartments up to and including 4 stories); HEAVY AND HIGHWAY CONSTRUCTION PROJECTS AND DREDGING

Note: Under Executive Order (EO) 13658, an hourly minimum wage of \$10.95 for calendar year 2021 applies to all contracts subject to the Davis-Bacon Act for which the contract is awarded (and any solicitation was issued) on or after January 1, 2015. If this contract is covered by the EO, the contractor must pay all workers in any classification listed on this wage determination at least \$10.95 per hour (or the applicable wage rate listed on this wage determination, if it is higher) for all hours spent performing on the contract in calendar year 2021. If this contract is covered by the EO and a classification considered necessary for performance of work on the contract does not appear on this wage determination, the contractor must pay workers in that classification at least the wage rate determined through the conformance process set forth in 29 CFR 5.5(a)(1)(ii) (or the EO minimum wage rate, if it is higher than the conformed wage rate). The EO minimum wage rate will be adjusted annually. Please note that this EO applies to the above-mentioned types of contracts entered into by the federal government that are subject to the Davis-Bacon Act itself, but it does not apply to contracts subject only to the Davis-Bacon Related Acts, including those set forth at 29 CFR 5.1(a)(2)-(60). Additional information on contractor requirements and worker protections under the EO is available at www.dol.gov/whd/govcontracts.

Modification Number	Publication Date
0	01/01/2021
1	01/08/2021
2	01/22/2021
3	02/12/2021
4	02/19/2021
5	03/19/2021
6	05/07/2021
7	07/02/2021

ASBE0132-001 08/30/2020

Rates

Fringes

Asbestos Workers/Insulator
 Includes application of
 all insulating materials,
 protective coverings,
 coatings and finishes to
 all types of mechanical
 systems. Also the
 application of
 firestopping material for
 wall openings and
 penetrations in walls,
 floors, ceilings and
 curtain walls.....\$ 41.90 25.65

 BOIL0627-005 01/01/2013

	Rates	Fringes
BOILERMAKER.....	\$ 35.20	27.35

 BRHI0001-001 08/31/2020

	Rates	Fringes
BRICKLAYER		
Bricklayers and Stonemasons.....	\$ 45.95	29.59
Pointers, Caulkers and Weatherproofers.....	\$ 46.21	29.59

 BRHI0001-002 08/31/2020

	Rates	Fringes
Tile, Marble & Terrazzo Worker		
Terrazzo Base Grinders.....	\$ 41.69	28.11
Terrazzo Floor Grinders and Tenders.....	\$ 40.14	28.11
Tile, Marble and Terrazzo Workers.....	\$ 43.50	28.11

 CARP0745-001 08/31/2020

	Rates	Fringes
Carpenters:		
Carpenters; Hardwood Floor Layers; Patent Scaffold Erectors (14 ft. and over); Piledrivers; Pneumatic Nailers; Wood Shinglers and Transit and/or Layout Man.....	\$ 50.50	23.59
Millwrights and Machine Erectors.....	\$ 50.75	23.59
Power Saw Operators (2 h.p. and over).....	\$ 50.65	23.59

CARP0745-002 08/31/2020

	Rates	Fringes
Drywall and Acoustical Workers and Lathers.....	\$ 50.50	23.59

ELEC1186-001 08/23/2020

	Rates	Fringes
Electricians:		
Cable Splicers.....	\$ 56.71	31.16
Electricians.....	\$ 51.55	29.58
Telecommunication worker....	\$ 32.69	12.96

ELEC1186-002 08/23/2020

	Rates	Fringes
Line Construction:		
Cable Splicers.....	\$ 56.71	31.16
Groundmen/Truck Drivers....	\$ 38.66	25.63
Heavy Equipment Operators...	\$ 46.40	28.00
Linemen.....	\$ 51.55	29.58
Telecommunication worker....	\$ 32.69	12.96

ELEV0126-001 01/01/2021

	Rates	Fringes
ELEVATOR MECHANIC.....	\$ 63.18	35.825+a+b

a. VACATION: Employer contributes 8% of basic hourly rate for 5 years service and 6% of basic hourly rate for 6 months to 5 years service as vacation pay credit.

b. PAID HOLIDAYS: New Year's Day, Memorial Day, Independence Day, Labor Day, Veterans' Day, Thanksgiving Day, the Friday after Thanksgiving Day and Christmas Day.

ENGI0003-002 09/03/2018

	Rates	Fringes
Diver (Aqua Lung) (Scuba))		
Diver (Aqua Lung) (Scuba) (over a depth of 30 feet)...	\$ 66.00	31.26
Diver (Aqua Lung) (Scuba) (up to a depth of 30 feet)..	\$ 56.63	31.26
Stand-by Diver (Aqua Lung) (Scuba).....	\$ 47.25	31.26
Diver (Other than Aqua Lung)		
Diver (Other than Aqua Lung).....	\$ 66.00	31.26
Diver Tender (Other than		

Aqua Lung).....\$ 44.22	31.26
Stand-by Diver (Other than Aqua Lung).....\$ 47.25	31.26
Helicopter Work	
Airborne Hoist Operator for Helicopter.....\$ 45.80	31.26
Co-Pilot of Helicopter.....\$ 45.98	31.26
Pilot of Helicopter.....\$ 46.11	31.26
Power equipment operator - tunnel work	
GROUP 1.....\$ 42.24	31.26
GROUP 2.....\$ 42.35	31.26
GROUP 3.....\$ 42.52	31.26
GROUP 4.....\$ 42.79	31.26
GROUP 5.....\$ 43.10	31.26
GROUP 6.....\$ 43.75	31.26
GROUP 7.....\$ 44.07	31.26
GROUP 8.....\$ 44.18	31.26
GROUP 9.....\$ 44.29	31.26
GROUP 9A.....\$ 44.52	31.26
GROUP 10.....\$ 44.58	31.26
GROUP 10A.....\$ 44.73	31.26
GROUP 11.....\$ 44.88	31.26
GROUP 12.....\$ 45.24	31.26
GROUP 12A.....\$ 45.60	31.26
Power equipment operators:	
GROUP 1.....\$ 41.94	31.26
GROUP 2.....\$ 42.05	31.26
GROUP 3.....\$ 42.22	31.26
GROUP 4.....\$ 42.49	31.26
GROUP 5.....\$ 42.80	31.26
GROUP 6.....\$ 43.45	31.26
GROUP 7.....\$ 43.77	31.26
GROUP 8.....\$ 43.88	31.26
GROUP 9.....\$ 43.99	31.26
GROUP 9A.....\$ 44.22	31.26
GROUP 10.....\$ 44.28	31.26
GROUP 10A.....\$ 44.43	31.26
GROUP 11.....\$ 44.58	31.26
GROUP 12.....\$ 44.94	31.26
GROUP 12A.....\$ 45.30	31.26
GROUP 13.....\$ 42.22	31.26
GROUP 13A.....\$ 42.49	31.26
GROUP 13B.....\$ 42.80	31.26
GROUP 13C.....\$ 43.45	31.26
GROUP 13D.....\$ 43.77	31.26
GROUP 13E.....\$ 43.88	31.26

POWER EQUIPMENT OPERATORS CLASSIFICATIONS

GROUP 1: Fork Lift (up to and including 10 tons); Partsman (heavy duty repair shop parts room when needed).

GROUP 2: Conveyor Operator (Handling building material); Hydraulic Monitor; Mixer Box Operator (Concrete Plant).

GROUP 3: Brakeman; Deckhand; Fireman; Oiler;

Oiler/Gradechecker; Signalman; Switchman; Highline Cableway Signalman; Bargeman; Bunkerman; Concrete Curing Machine (self-propelled, automatically applied unit on streets, highways, airports and canals); Leveeman; Roller (5 tons and under); Tugger Hoist.

GROUP 4: Boom Truck or dual purpose "A" Frame Truck (5 tons or less); Concrete Placing Boom (Building Construction); Dinky Operator; Elevator Operator; Hoist and/or Winch (one drum); Straddle Truck (Ross Carrier, Hyster and similar).

GROUP 5: Asphalt Plant Fireman; Compressors, Pumps, Generators and Welding Machines ("Bank" of 9 or more, individually or collectively); Concrete Pumps or Pumpcrete Guns; Lubrication and Service Engineer (Grease Rack); Screedman.

GROUP 6: Boom Truck or Dual Purpose "A" Frame Truck (over 5 tons); Combination Loader/Backhoe (up to and including 3/4 cu. yd.); Concrete Batch Plants (wet or dry); Concrete Cutter, Groover and/or Grinder (self-propelled unit on streets, highways, airports, and canals); Conveyor or Concrete Pump (Truck or Equipment Mounted); Drilling Machinery (not to apply to waterliners, wagon drills or jack hammers); Fork Lift (over 10 tons); Loader (up to and including 3 and 1/2 cu. yds); Lull High Lift (under 40 feet); Lubrication and Service Engineer (Mobile); Maginnis Internal Full Slab Vibrator (on airports, highways, canals and warehouses); Man or Material Hoist; Mechanical Concrete Finisher (Large Clary, Johnson Bidwell, Bridge Deck and similar); Mobile Truck Crane Driver; Portable Shotblast Concrete Cleaning Machine; Portable Boring Machine (under streets, highways, etc.); Portable Crusher; Power Jumbo Operator (setting slip forms, etc., in tunnels); Rollers (over 5 tons); Self-propelled Compactor (single engine); Self-propelled Pavement Breaker; Skidsteer Loader with attachments; Slip Form Pumps (Power driven by hydraulic, electric, air, gas, etc., lifting device for concrete forms); Small Rubber Tired Tractors; Trencher (up to and including 6 feet); Underbridge Personnel Aerial Platform (50 feet of platform or less).

GROUP 7: Crusher Plant Engineer, Dozer (D-4, Case 450, John Deere 450, and similar); Dual Drum Mixer, Extend Lift; Hoist and/or Winch (2 drums); Loader (over 3 and 1/2 cu. yds. up to and including 6 yards.); Mechanical Finisher or Spreader Machine (asphalt), (Barber Greene and similar) (Screedman required); Mine or Shaft Hoist; Mobile Concrete Mixer (over 5 tons); Pipe Bending Machine (pipelines only); Pipe Cleaning Machine (tractor propelled and supported); Pipe Wrapping Machine (tractor propelled and supported); Roller Operator (Asphalt); Self-Propelled Elevating Grade Plane; Slusher Operator; Tractor (with boom) (D-6, or similar); Trencher (over 6 feet and less than 200 h.p.); Water Tanker (pulled by Euclids, T-Pulls, DW-10, 20 or 21, or similar); Winchman (Stern Winch on Dredge).

GROUP 8: Asphalt Plant Operator; Barge Mate (Seagoing); Cast-in-Place Pipe Laying Machine; Concrete Batch Plant (multiple units); Conveyor Operator (tunnel); Deckmate; Dozer (D-6 and similar); Finishing Machine Operator (airports and highways); Gradesetter; Kolman Loader (and similar); Mucking Machine (Crawler-type); Mucking Machine (Conveyor-type); No-Joint Pipe Laying Machine; Portable Crushing and Screening Plant; Power Blade Operator (under 12); Saurman Type Dragline (up to and including 5 yds.); Stationary Pipe Wrapping, Cleaning and Bending Machine; Surface Heater and Planer Operator, Tractor (D-6 and similar); Tri-Batch Paver; Tunnel Badger; Tunnel Mole and/or Boring Machine Operator Underbridge Personnel Aerial Platform (over 50 feet of platform).

GROUP 9: Combination Mixer and Compressor (gunite); Do-Mor Loader and Adams Elegrader; Dozer (D-7 or equal); Wheel and/or Ladder Trencher (over 6 feet and 200 to 749 h.p.).

GROUP 9A: Dozer (D-8 and similar); Gradesetter (when required by the Contractor to work from drawings, plans or specifications without the direct supervision of a foreman or superintendent); Push Cat; Scrapers (up to and including 20 cu. yds); Self-propelled Compactor with Dozer; Self-Propelled, Rubber-Tired Earthmoving Equipment (up to and including 20 cu. yds) (621 Band and similar); Sheep's Foot; Tractor (D-8 and similar); Tractors with boom (larger than D-6, and similar).

GROUP 10: Chicago Boom; Cold Planers; Heavy Duty Repairman or Welder; Hoist and/or Winch (3 drums); Hydraulic Skooper (Koehring and similar); Loader (over 6 cu. yds. up to and including 12 cu. yds.); Saurman type Dragline (over 5 cu. yds.); Self-propelled, rubber-tired Earthmoving Equipment (over 20 cu. yds. up to and including 31 cu. yds.) (637D and similar); Soil Stabilizer (P & H or equal); Sub-Grader (Gurries or other automatic type); Tractors (D-9 or equivalent, all attachments); Tractor (Tandem Scraper); Watch Engineer.

GROUP 10A: Boat Operator; Cable-operated Crawler Crane (up to and including 25 tons); Cable-operated Power Shovel, Clamshell, Dragline and Backhoe (up to and including 1 cu. yd.); Dozer D9-L; Dozer (D-10, HD41 and similar) (all attachments); Gradall (up to and including 1 cu. yd.); Hydraulic Backhoe (over 3/4 cu. yds. up to and including 2 cu. yds.); Mobile Truck Crane Operator (up to and including 25 tons) (Mobile Truck Crane Driver Required); Self-propelled Boom Type Lifting Device (Center Mount) (up to and including 25 tons) (Grove, Drott, P&H, Pettibone and similar); Trencher (over 6 feet and 750 h.p. or more); Watch Engineer (steam or electric).

GROUP 11: Automatic Slip Form Paver (concrete or asphalt); Band Wagon (in conjunction with Wheel Excavator); Cable-operated Crawler Cranes (over 25 tons but less than 50 tons); Cable-operated Power Shovel, Clamshell, Dragline

and Backhoe (over 1 cu. yd. up to 7 cu. yds.); Gradall (over 1 cu. yds. up to 7 cu. yds.); DW-10, 20, etc. (Tandem); Earthmoving Machines (multiple propulsion power units and 2 or more Scrapers) (up to and including 35 cu. yds., "struck" m.r.c.); Highline Cableway; Hydraulic Backhoe (over 2 cu. yds. up to and including 4 cu. yds.); Leverman; Lift Slab Machine; Loader (over 12 cu. yds); Master Boat Operator; Mobile Truck Crane Operator (over 25 tons but less than 50 tons); (Mobile Truck Crane Driver required); Pre-stress Wire Wrapping Machine; Self-propelled Boom-type Lifting Device (Center Mount) (over 25 tons m.r.c); Self-propelled Compactor (with multiple-propulsion power units); Single Engine Rubber Tired Earthmoving Machine (with Tandem Scraper); Tandem Cats; Trencher (pulling attached shield).

GROUP 12: Clamshell or Dipper Operator; Derricks; Drill Rigs; Multi-Propulsion Earthmoving Machines (2 or more Scrapers) (over 35 cu. yds "struck" m.r.c.); Operators (Derricks, Piledrivers and Cranes); Power Shovels and Draglines (7 cu. yds. m.r.c. and over); Self-propelled rubber-tired Earthmoving equipment (over 31 cu. yds.) (657B and similar); Wheel Excavator (up to and including 750 cu. yds. per hour); Wheel Excavator (over 750 cu. yds. per hour).

GROUP 12A: Dozer (D-11 or similar or larger); Hydraulic Excavators (over 4 cu. yds.); Lifting cranes (50 tons and over); Pioneering Dozer/Backhoe (initial clearing and excavation for the purpose of providing access for other equipment where the terrain worked involves 1-to-1 slopes that are 50 feet in height or depth, the scope of this work does not include normal clearing and grubbing on usual hilly terrain nor the excavation work once the access is provided); Power Blade Operator (Cat 12 or equivalent or over); Straddle Lifts (over 50 tons); Tower Crane, Mobile; Traveling Truss Cranes; Universal, Liebherr, Linden, and similar types of Tower Cranes (in the erection, dismantling, and moving of equipment there shall be an additional Operating Engineer or Heavy Duty Repairman); Yo-Yo Cat or Dozer.

GROUP 13: Truck Driver (Utility, Flatbed, etc.)

GROUP 13A: Dump Truck, 8 cu.yds. and under (water level); Water Truck (up to and including 2,000 gallons).

GROUP 13B: Water Truck (over 2,000 gallons); Tandem Dump Truck, over 8 cu. yds. (water level).

GROUP 13C: Truck Driver (Semi-trailer. Rock Cans, Semi-Dump or Roll-Offs).

GROUP 13D: Truck Driver (Slip-In or Pup).

GROUP 13E: End Dumps, Unlicensed (Euclid, Mack, Caterpillar or similar); Tractor Trailer (Hauling Equipment); Tandem Trucks hooked up to Trailer (Hauling Equipment)

BOOMS AND/OR LEADS (HOURLY PREMIUMS):

The Operator of a crane (under 50 tons) with a boom of 80 feet or more (including jib), or of a crane (under 50 tons) with leads of 100 feet or more, shall receive a per hour premium for each hour worked on said crane (under 50 tons) in accordance with the following schedule:

Booms of 80 feet up to but not including 130 feet or Leads of 100 feet up to but not including 130 feet	0.50
Booms and/or Leads of 130 feet up to but not including 180 feet	0.75
Booms and/or Leads of 180 feet up to and including 250 feet	1.15
Booms and/or Leads over 250 feet	1.50

The Operator of a crane (50 tons and over) with a boom of 180 feet or more (including jib) shall receive a per hour premium for each hour worked on said crane (50 tons and over) in accordance with the following schedule:

Booms of 180 feet up to and including 250 feet	1.25
Booms over 250 feet	1.75

 ENGI0003-004 09/04/2017

	Rates	Fringes
Dredging: (Boat Operators)		
Boat Deckhand.....	\$ 41.22	30.93
Boat Operator.....	\$ 43.43	30.93
Master Boat Operator.....	\$ 43.58	30.93
Dredging: (Clamshell or Dipper Dredging)		
GROUP 1.....	\$ 43.94	30.93
GROUP 2.....	\$ 43.28	30.93
GROUP 3.....	\$ 42.88	30.93
GROUP 4.....	\$ 41.22	30.93
Dredging: (Derricks)		
GROUP 1.....	\$ 43.94	30.93
GROUP 2.....	\$ 43.28	30.93
GROUP 3.....	\$ 42.88	30.93
GROUP 4.....	\$ 41.22	30.93
Dredging: (Hydraulic Suction Dredges)		
GROUP 1.....	\$ 43.58	30.93
GROUP 2.....	\$ 43.43	30.93
GROUP 3.....	\$ 43.28	30.93
GROUP 4.....	\$ 43.22	30.93
GROUP 5.....	\$ 37.88	26.76
Group 5.....	\$ 42.88	30.93

GROUP 6.....	\$ 37.77	26.76
Group 6.....	\$ 42.77	30.93
GROUP 7.....	\$ 36.22	26.76
Group 7.....	\$ 41.22	30.93

CLAMSHELL OR DIPPER DREDGING CLASSIFICATIONS

- GROUP 1: Clamshell or Dipper Operator.
- GROUP 2: Mechanic or Welder; Watch Engineer.
- GROUP 3: Barge Mate; Deckmate.
- GROUP 4: Bargeman; Deckhand; Fireman; Oiler.

HYDRAULIC SUCTION DREDGING CLASSIFICATIONS

- GROUP 1: Leverman.
- GROUP 2: Watch Engineer (steam or electric).
- GROUP 3: Mechanic or Welder.
- GROUP 4: Dozer Operator.
- GROUP 5: Deckmate.
- GROUP 6: Winchman (Stern Winch on Dredge)
- GROUP 7: Deckhand (can operate anchor scow under direction of Deckmate); Fireman; Leveeman; Oiler.

DERRICK CLASSIFICATIONS

- GROUP 1: Operators (Derricks, Piledrivers and Cranes).
- GROUP 2: Saurman Type Dragline (over 5 cubic yards).
- GROUP 3: Deckmate; Saurman Type Dragline (up to and including 5 yards).
- GROUP 4: Deckhand, Fireman, Oiler.

 ENGI0003-044 09/03/2018

	Rates	Fringes
Power Equipment Operators (PAVING)		
Asphalt Concrete Material Transfer.....	\$ 42.92	32.08
Asphalt Plant Operator.....	\$ 43.35	32.08
Asphalt Raker.....	\$ 41.96	32.08
Asphalt Spreader Operator...\$	43.44	32.08
Cold Planer.....	\$ 43.75	32.08
Combination Loader/Backhoe (over 3/4 cu.yd.).....	\$ 41.96	32.08
Combination Loader/Backhoe (up to 3/4 cu.yd.).....	\$ 40.98	32.08
Concrete Saws and/or Grinder (self-propelled unit on streets, highways, airports and canals).....	\$ 42.92	32.08
Grader.....	\$ 43.75	32.08
Laborer, Hand Roller.....	\$ 41.46	32.08
Loader (2 1/2 cu. yds. and under).....	\$ 42.92	32.08
Loader (over 2 1/2 cu.		

yds. to and including 5 cu. yds.).....	\$ 43.24	32.08
Roller Operator (five tons and under).....	\$ 41.69	32.08
Roller Operator (over five tons).....	\$ 43.12	32.08
Screed Person.....	\$ 42.92	32.08
Soil Stabilizer.....	\$ 43.75	32.08

IRON0625-001 09/01/2020

	Rates	Fringes
Ironworkers:.....	\$ 42.50	36.84
a. Employees will be paid \$.50 per hour more while working in tunnels and coffer dams; \$1.00 per hour more when required to work under or are covered with water (submerged) and when they are required to work on the summit of Mauna Kea, Mauna Loa or Haleakala.		

LAB00368-001 09/02/2020

	Rates	Fringes
Laborers:		
Driller.....	\$ 39.70	22.68
Final Clean Up.....	\$ 29.65	18.17
Guniting/Shotcrete Operator and High Scaler.....	\$ 39.20	22.68
Laborer I.....	\$ 38.70	22.68
Laborer II.....	\$ 36.10	22.68
Mason Tender/Hod Carrier....	\$ 39.20	22.68
Powderman.....	\$ 39.70	22.68
Window Washer (bosun chair).\$	38.20	22.68

LABORERS CLASSIFICATIONS

Laborer I: Air Blasting run by electric or pneumatic compressor; Asphalt Laborer, Ironer, Raker, Luteman, and Handroller, and all types of Asphalt Spreader Boxes; Asphalt Shoveler; Assembly and Installation of Multiplates, Liner Plates, Rings, Mesh, Mats; Batching Plant (portable and temporary); Boring Machine Operator (under streets and sidewalks); Buggymobile; Burning and Welding; Chainsaw, Faller, Logloader, and Bucker; Compactors (Jackson Jumping Jack and similar); Concrete Bucket Dumpman; Concrete Chipping; Concrete Chuteman/Hoseman (pouring concrete) (the handling of the chute from ready-mix trucks for such jobs as walls, slabs, decks, floors, foundations, footings, curbs, gutters, and sidewalks); Concrete Core Cutter (Walls, Floors, and Ceiling); Concrete Grinding or Sanding; Concrete: Hooking on, signaling, dumping of concrete for treme work over water on caissons, pilings, abutments, etc.; Concrete: Mixing, handling, conveying, pouring, vibrating, otherwise placing of concrete or aggregates or by any other process; Concrete: Operation of motorized wheelbarrows or buggies or machines of similar character,

whether run by gas, diesel, or electric power; Concrete Placement Machine Operator: operation of Somero Hammerhead, Copperheads, or similar machines; Concrete Pump Machine (laying, coupling, uncoupling of all connections and cleaning of equipment); Concrete and/or Asphalt Saw (Walking or Handtype) (cutting walls or flatwork) (scoring old or new concrete and/or asphalt) (cutting for expansion joints) (streets and ways for laying of pipe, cable or conduit for all purposes); Concrete Shovelers/Laborers (Wet or Dry); Concrete Screeding for Rough Strike-Off: Rodding or striking-off, by hand or mechanical means prior to finishing; Concrete Vibrator Operator; Coring Holes: Walls, footings, piers or other obstructions for passage of pipes or conduits for any purpose and the pouring of concrete to secure the hole; Cribbers, Shorer, Lagging, Sheeting, and Trench Jacking and Bracing, Hand-Guided Lagging Hammer Whaling Bracing; Curbing (Concrete and Asphalt); Curing of Concrete (impervious membrane and form oiler) mortar and other materials by any mode or method; Cut Granite Curb Setter (setting, leveling and grouting of all precast concrete or stone curbs); Cutting and Burning Torch (demolition); Dri Pak-It Machine; Environmental Abatement: removal of asbestos, lead, and bio hazardous materials (EPA and/or OSHA certified); Falling, bucking, yarding, loading or burning of all trees or timber on construction site; Forklift (9 ft. and under); Gas, Pneumatic, and Electric tools; Grating and Grill work for drains or other purposes; Green Cutter of concrete or aggregate in any form, by hand, mechanical means, grindstone or air and/or water; Grout: Spreading for any purpose; Guinea Chaser (Grade Checker) for general utility trenches, sitework, and excavation; Headerboard Man (Asphalt or Concrete); Heat Welder of Plastic (Laborers' AGC certified workers) (when work involves waterproofing for waterponds, artificial lakes and reservoir) heat welding for sewer pipes and fusion of HDPE pipes; Heavy Highway Laborer (Rigging, signaling, handling, and installation of pre-cast catch basins, manholes, curbs and gutters); High Pressure Nozzleman - Hydraulic Monitor (over 100# pressure); Jackhammer Operator; Jacking of slip forms: All semi and unskilled work connected therewithin; Laying of all multi-cell conduit or multi-purpose pipe; Magnesite and Mastic Workers (Wet or Dry)(including mixer operator);Mortar Man; Mortar Mixer (Block, Brick, Masonry, and Plastering); Nozzleman (Sandblasting and/or Water Blasting): handling, placing and operation of nozzle; Operation, Manual or Hydraulic jacking of shields and the use of such other mechanical equipment as may be necessary; Pavement Breakers; Paving, curbing and surfacing of streets, ways, courts, under and overpasses, bridges, approaches, slope walls, and all other labor connected therewith; Pilecutters; Pipe Accessment in place, bolting and lining up of sectional metal or other pipe including corrugated pipe; Pipelayer performing all services in the laying and installation of pipe from the point of receiving pipe in the ditch until completion of operation, including any and all forms of tubular material, whether pipe, HDPE, metallic or non-metallic, conduit, and any other

stationary-type of tubular device used for conveying of any substance or element, whether water, sewage, solid, gas, air, or other product whatsoever and without regard to the nature of material from which tubular material is fabricated; No-joint pipe and stripping of same, Pipewrapper, Caulker, Bander, Kettlemen, and men applying asphalt, Laykold, treating Creosote and similar-type materials (6-inch) pipe and over); Piping: resurfacing and paving of all ditches in preparation for laying of all pipes; Pipe laying of lateral sewer pipe from main or side sewer to buildings or structure (except Contactor may direct work be done under proper supervision); Pipe laying, leveling and marking of the joint used for main or side sewers and storm sewers; Laying of all clay, terra cotta, ironstone, vitrified concrete, HDPE or other pipe for drainage; Placing and setting of water mains, gas mains and all pipe including removal of skids; Plaster Mortar Mixer/Pump; Pneumatic Impact Wrench; Portable Sawmill Operation: Choker setters, off bearers, and lumber handlers connected with clearing; Posthole Digger (Hand Held, Gas, Air and Electric); Powderman's Tender; Power Broom Sweepers (Small); Preparation and Compaction of roadbeds for railroad track laying, highway construction, and the preparation of trenches, footings, etc., for cross-country transmission by pipelines, electrical transmission or underground lines or cables (by mechanical means); Raising of structure by manual or hydraulic jacks or other methods and resetting of structure in new locations, including all concrete work; Ramming or compaction; Rigging in connection with Laborers' work (except demolition), Signaling (including the use of walkie talkie) Choke Setting, tag line usage; Tagging and Signaling of building materials into high rise units; Riprap, Stonepaver, and Rock Slinger (includes placement of stacked concrete, wet or dry and loading, unloading, signaling, slinging and setting of other similar materials); Rotary Scarifier (including multiple head concrete chipping Scarifier); Salamander Heater, Drying of plaster, concrete mortar or other aggregate; Scaffold Erector Leadman; Scaffolds: (Swing and hanging) including maintenance thereof; Scaler; Septic Tank/Cesspool and Drain Fields Digger and Installer; Shredder/Chipper (tree branches, brush, etc.); Stripping and Setting Forms; Stripping of Forms: Other than panel forms which are to be re-used in their original form, and stripping of forms on all flat arch work; Tampers (Barko, Wacker, and similar type); Tank Scaler and Cleaners; Tarman; Tree Climbers and Trimmers; Trencher (includes hand-held, Davis T-66 and similar type); Trucks (flatbed up to and including 2 1/2 tons when used in connection with on-site Laborers' work; Trucks (Refuse and Garbage Disposal) (from job site to dump); Vibra-Screed (Bull Float in connection with Laborers' work); Well Points, Installation of or any other dewatering system.

Laborer II: Asphalt Plant Laborer; Boring Machine Tender; Bridge Laborer; Burning of all debris (crates, boxes, packaging waste materials); Chainman, Rodmen, and Grade

Markers; Cleaning, clearing, grading and/or removal for streets, highways, roadways, aprons, runways, sidewalks, parking areas, airports, approaches, and other similar installations; Cleaning or reconditioning of streets, ways, sewers and waterlines, all maintenance work and work of an unskilled and semi-skilled nature; Concrete Bucket Tender (Groundman) hooking and unhooking of bucket; Concrete Forms; moving, cleaning, oiling and carrying to the next point of erection of all forms; Concrete Products Plant Laborers; Conveyor Tender (conveying of building materials); Crushed Stone Yards and Gravel and Sand Pit Laborers and all other similar plants; Demolition, Wrecking and Salvage Laborers: Wrecking and dismantling of buildings and all structures, with use of cutting or wrecking tools, breaking away, cleaning and removal of all fixtures, All hooking, unhooking, signaling of materials for salvage or scrap removed by crane or derrick; Digging under streets, roadways, aprons or other paved surfaces; Driller's Tender; Chuck Tender, Outside Nipper; Dry-packing of concrete (plugging and filling of she-bolt holes); Fence and/or Guardrail Erector: Dismantling and/or re-installation of all fence; Finegrader; Firewatcher; Flagman (Coning, preparing, stablishing and removing portable roadway barricade devices); Signal Men on all construction work defined herein, including Traffic Control Signal Men at construction site; General Excavation; Backfilling, Grading and all other labor connected therewith; Digging of trenches, ditches and manholes and the leveling, grading and other preparation prior to laying pipe or conduit for any purpose; Excavations and foundations for buildings, piers, foundations and holes, and all other construction. Preparation of street ways and bridges; General Laborer: Cleaning and Clearing of all debris and surplus material. Clean-up of right-of-way. Clearing and slashing of brush or trees by hand or mechanical cutting. General Clean up: sweeping, cleaning, wash-down, wiping of construction facility and equipment (other than "Light Clean up (Janitorial) Laborer. Garbage and Debris Handlers and Cleaners. Appliance Handling (job site) (after delivery unloading in storage area); Ground and Soil Treatment Work (Pest Control); Guniting/Shotcrete Operator Tender; Junk Yard Laborers (same as Salvage Yard); Laser Beam "Target Man" in connection with Laborers' work; Layout Person for Plastic (when work involves waterproofing for waterponds, artificial lakes and reservoirs); Limbers, Brush Loaders, and Pilers; Loading, Unloading, carrying, distributing and handling of all rods and material for use in reinforcing concrete construction (except when a derrick or outrigger operated by other than hand power is used); Loading, unloading, sorting, stockpiling, handling and distribution of water mains, gas mains and all pipes; Loading and unloading of all materials, fixtures, furnishings and appliances from point of delivery to stockpile to point of installation; hooking and signaling from truck, conveyance or stockpile; Material Yard Laborers; Pipelayer Tender; Pipewrapper, Caulker, Bander, Kettlemen, and men applying asphalt, Laykold, Creosote, and similar-type materials

(pipe under 6 inches); Plasterer Laborer; Preparation, construction and maintenance of roadbeds and sub-grade for all paving, including excavation, dumping, and spreading of sub-grade material; Prestressed or precast concrete slabs, walls, or sections: all loading, unloading, stockpiling, hooking on of such slabs, walls or sections; Quarry Laborers; Railroad, Streetcar, and Rail Transit Maintenance and Repair; Roustabout; Rubbish Trucks in connection with Building Construction Projects (excluding clearing, grubbing, and excavating); Salvage Yard: All work connected with cutting, cleaning, storing, stockpiling or handling of materials, all cleanup, removal of debris, burning, back-filling and landscaping of the site; Sandblasting Tender (Pot Tender): Hoses and pots or markers; Scaffolds: Erection, planking and removal of all scaffolds used for support for lathers, plasters, brick layers, masons, and other construction trades crafts; Scaffolds: (Specially designed by carpenters) laborers shall tend said carpenter on erection and dismantling thereof, preparation for foundation or mudsills, maintenance; Scraping of floors; Screeds: Handling of all screeds to be reused; handling, dismantling and conveyance of screeds; Setting, leveling and securing or bracing of metal or other road forms and expansion joints; Sheeting Piling/trench shoring (handling and placing of skip sheet or wood plank trench shoring); Ship Scalers; Shipwright Tender; Sign Erector (subdivision traffic, regulatory, and street-name signs); Sloper; Slurry Seal Crews (Mixer Operator, Applicator, Squeegee Man, Shuttle Man, Top Man); Snapping of wall ties and removal of tie rods; Soil Test operations of semi and unskilled labor such as filling sand bags; Striper (Asphalt, Concrete or other Paved Surfaces); Tool Room Attendant (Job Site); Traffic Delineating Device Applicator; Underpinning, lagging, bracing, propping and shoring, loading, signaling, right-of-way clearance along the route of movement, The clearance of new site, excavation of foundation when moving a house or structure from old site to new site; Utilities employees; Water Man; Waterscape/Hardscape Laborers; Wire Mesh Pulling (all concrete pouring operations); Wrecking, stripping, dismantling and handling concrete forms an false work.

 LAB00368-002 09/01/2020

	Rates	Fringes
Landscape & Irrigation Laborers		
GROUP 1.....	\$ 26.40	14.25
GROUP 2.....	\$ 27.40	14.25
GROUP 3.....	\$ 21.70	14.25

LABORERS CLASSIFICATIONS

GROUP 1: Installation of non-potable permanent or temporary irrigation water systems performed for the purposes of

Landscaping and Irrigation architectural horticultural work; the installation of drinking fountains and permanent or temporary irrigation systems using potable water for Landscaping and Irrigation architectural horticultural purposes only. This work includes (a) the installation of all heads, risers, valves, valve boxes, vacuum breakers (pressure and non-pressure), low voltage electrical lines and, provided such work involves electrical wiring that will carry 24 volts or less, the installation of sensors, master control panels, display boards, junction boxes, conductors, including all other components for controllers, (b) and metallic (copper, brass, galvanized, or similar) pipe, as well as PVC or other plastic pipe including all work incidental thereto, i.e., unloading, handling and distribution of all pipes fittings, tools, materials and equipment, (c) all soldering work in connection with the above whether done by torch, soldering iron, or other means; (d) tie-in to main lines, thrust blocks (both precast and poured in place), pipe hangers and supports incidental to installation of the entire irrigation system, (e) making of pressure tests, start-up testing, flushing, purging, water balancing, placing into operation all irrigation equipment, fixtures and appurtenances installed under this agreement, and (f) the fabrication, replacement, repair and servicing of landscaping and irrigation systems. Operation of hand-held gas, air, electric, or self-powered tools and equipment used in the performance of Landscape and Irrigation work in connection with architectural horticulture; Choke-setting, signaling, and rigging for equipment operators on job-site in the performance of such Landscaping and Irrigation work; Concrete work (wet or dry) performed in connection with such Landscaping and Irrigation work. This work shall also include the setting of rock, stone, or riprap in connection with such Landscape, Waterscape, Rockscape, and Irrigation work; Grubbing, pick and shovel excavation, and hand rolling or tamping in connection with the performance of such Landscaping and Irrigation work; Sprigging, handseeding, and planting of trees, shrubs, ground covers, and other plantings and the performance of all types of gardening and horticultural work relating to said planting; Operation of flat bed trucks (up to and including 2 1/2 tons).:

GROUP 2. Layout of irrigation and other non-potable irrigation water systems and the layout of drinking fountains and other potable irrigation water systems in connection with such Landscaping and Irrigation work. This includes the layout of all heads, risers, valves, valve boxes, vacuum breakers, low voltage electrical lines, hydraulic and electrical controllers, and metallic (coppers, brass, galvanized, or similar) pipe, as well as PVC or other plastic pipe. This work also includes the reading and interpretation of plans and specifications in connection with the layout of Landscaping, Rockscape, Waterscape, and Irrigation work; Operation of Hydro-Mulching machines (sprayman and driver), Drillers, Trenchers (riding type, Davis T-66, and similar) and fork

lifts used in connection with the performance of such Landscaping and Irrigation work; Tree climbers and chain saw tree trimmers, Sporadic operation (when used in connection with Landscaping, Rockscape, Waterscape, and Irrigation work) of Skid-Steer Loaders (Bobcat and similar), Cranes (Bantam, Grove, and similar), Hoptos, Backhoes, Loaders, Rollers, and Dozers (Case, John Deere, and similar), Water Trucks, Trucks requiring a State of Hawaii Public Utilities Commission Type 5 and/or type 7 license, sit-down type and "gang" mowers, and other self-propelled, sit-down operated machines not listed under Landscape & Irrigation Maintenance Laborer; Chemical spraying using self-propelled power spraying equipment (200 gallon capacity or more).

GROUP 3: Maintenance of trees, shrubs, ground covers, lawns and other planted areas, including the replanting of trees, shrubs, ground covers, and other plantings that did not "take" or which are damaged; provided, however, that re-planting that requires the use of equipment, machinery, or power tools shall be paid for at the rate of pay specified under Landscape and Irrigation Laborer, Group 1; Raking, mowing, trimming, and runing, including the use of "weed eaters", hedge trimmers, vacuums, blowers, and other hand-held gas, air, electric, or self-powered tools, and the operation of lawn mowers (Note: The operation of sit-down type and "gang" mowers shall be paid for at the rate of pay specified under Landscape & Irrigation Laborer, Group 2); Guywiring, staking, propping, and supporting trees; Fertilizing, Chemical spraying using spray equipment with less than 200 gallon capacity, Maintaining irrigation and sprinkler systems, including the staking, clamping, and adjustment of risers, and the adjustment and/or replacement of sprinkler heads, (Note: the cleaning and gluing of pipe and fittings shall be paid for at the rate of pay specified under Landscape & Irrigation Laborer(Group 1)); Watering by hand or sprinkler system and the performance of other types of gardening, yardman, and horticultural-related work.

 LAB00368-003 09/02/2020

	Rates	Fringes
Underground Laborer		
GROUP 1.....	\$ 39.30	22.68
GROUP 2.....	\$ 40.80	22.68
GROUP 3.....	\$ 41.30	22.68
GROUP 4.....	\$ 42.30	22.68
GROUP 5.....	\$ 42.65	22.68
GROUP 6.....	\$ 42.90	22.68
GROUP 7.....	\$ 43.35	22.68

GROUP 1: Watchmen; Change House Attendant.

GROUP 2: Swamper; Brakeman; Bull Gang-Muckers, Trackmen; Dumpmen (any method); Concrete Crew (includes rodding and

spreading); Grout Crew; Reboundmen

GROUP 3: Chucktenders and Cabetenders; Powderman (Prime House); Vibratorman, Pavement Breakers

GROUP 4: Miners - Tunnel (including top and bottom man on shaft and raise work); Timberman, Retimberman (wood or steel or substitute materials thereof); Blasters, Drillers, Powderman (in heading); Microtunnel Laborer; Headman; Cherry Pickerman (where car is lifted); Nipper; Grout Gunmen; Grout Pumpman & Potman; Gunitite, Shotcrete Gunmen & Potmen; Concrete Finisher (in tunnel); Concrete Screed Man; Bit Grinder; Steel Form Raisers & Setters; High Pressure Nozzlemans; Nozzlemans (on slick line); Sandblaster-Potman (combination work assignment interchangeable); Tugger

GROUP 5: Shaft Work & Raise (below actual or excavated ground level); Diamond Driller; Gunitite or Shotcrete Nozzlemans; Rodman; Groundman

GROUP 6: Shifter

GROUP 7: Shifter (Shaft Work & Raiser)

 * PAIN1791-001 07/01/2021

	Rates	Fringes
Painters:		
Brush.....	\$ 38.90	30.09
Sandblaster; Spray.....	\$ 38.90	30.09

 PAIN1889-001 07/01/2020

	Rates	Fringes
Glaziers.....	\$ 39.50	34.85

 PAIN1926-001 02/28/2021

	Rates	Fringes
Soft Floor Layers.....	\$ 37.77	32.07

 PAIN1944-001 01/05/2020

	Rates	Fringes
Taper.....	\$ 43.10	29.90

 PLAS0630-001 08/31/2020

	Rates	Fringes
PLASTERER.....	\$ 43.69	31.68

PLAS0630-002 08/31/2020

	Rates	Fringes
Cement Masons:		
Cement Masons.....	\$ 42.65	32.29
Trowel Machine Operators....	\$ 42.80	32.29

 PLUM0675-001 01/03/2021

	Rates	Fringes
Plumber, Pipefitter, Steamfitter & Sprinkler Fitter...	\$ 51.43	24.55

 ROOF0221-001 09/06/2020

	Rates	Fringes
Roofers (Including Built Up, Composition and Single Ply).....	\$ 41.80	20.50

 SHEE0293-001 09/02/2018

	Rates	Fringes
Sheet metal worker.....	\$ 42.55	27.44

 SUHI1997-002 09/15/1997

	Rates	Fringes
Drapery Installer.....	\$ 13.60	1.20
FENCE ERECTOR (Chain Link Fence).....	\$ 9.33	1.65

 WELDERS - Receive rate prescribed for craft performing operation to which welding is incidental.

=====

Note: Executive Order (EO) 13706, Establishing Paid Sick Leave for Federal Contractors applies to all contracts subject to the Davis-Bacon Act for which the contract is awarded (and any solicitation was issued) on or after January 1, 2017. If this contract is covered by the EO, the contractor must provide employees with 1 hour of paid sick leave for every 30 hours they work, up to 56 hours of paid sick leave each year. Employees must be permitted to use paid sick leave for their own illness, injury or other health-related needs, including preventive care; to assist a family member (or person who is like family to the employee) who is ill, injured, or has other health-related needs, including preventive care; or for reasons resulting from, or to assist a family member (or person who is like family to the employee) who is a victim of, domestic

violence, sexual assault, or stalking. Additional information on contractor requirements and worker protections under the EO is available at www.dol.gov/whd/govcontracts.

Unlisted classifications needed for work not included within the scope of the classifications listed may be added after award only as provided in the labor standards contract clauses (29CFR 5.5 (a) (1) (ii)).

The body of each wage determination lists the classification and wage rates that have been found to be prevailing for the cited type(s) of construction in the area covered by the wage determination. The classifications are listed in alphabetical order of ""identifiers"" that indicate whether the particular rate is a union rate (current union negotiated rate for local), a survey rate (weighted average rate) or a union average rate (weighted union average rate).

Union Rate Identifiers

A four letter classification abbreviation identifier enclosed in dotted lines beginning with characters other than ""SU"" or ""UAVG"" denotes that the union classification and rate were prevailing for that classification in the survey. Example: PLUM0198-005 07/01/2014. PLUM is an abbreviation identifier of the union which prevailed in the survey for this classification, which in this example would be Plumbers. 0198 indicates the local union number or district council number where applicable, i.e., Plumbers Local 0198. The next number, 005 in the example, is an internal number used in processing the wage determination. 07/01/2014 is the effective date of the most current negotiated rate, which in this example is July 1, 2014.

Union prevailing wage rates are updated to reflect all rate changes in the collective bargaining agreement (CBA) governing this classification and rate.

Survey Rate Identifiers

Classifications listed under the ""SU"" identifier indicate that no one rate prevailed for this classification in the survey and the published rate is derived by computing a weighted average rate based on all the rates reported in the survey for that classification. As this weighted average rate includes all rates reported in the survey, it may include both union and non-union rates. Example: SULA2012-007 5/13/2014. SU indicates the rates are survey rates based on a weighted average calculation of rates and are not majority rates. LA indicates the State of Louisiana. 2012 is the year of survey on which these classifications and rates are based. The next number, 007 in the example, is an internal number used in producing the wage determination. 5/13/2014 indicates the survey completion

date for the classifications and rates under that identifier.

Survey wage rates are not updated and remain in effect until a new survey is conducted.

Union Average Rate Identifiers

Classification(s) listed under the UAVG identifier indicate that no single majority rate prevailed for those classifications; however, 100% of the data reported for the classifications was union data. EXAMPLE: UAVG-OH-0010 08/29/2014. UAVG indicates that the rate is a weighted union average rate. OH indicates the state. The next number, 0010 in the example, is an internal number used in producing the wage determination. 08/29/2014 indicates the survey completion date for the classifications and rates under that identifier.

A UAVG rate will be updated once a year, usually in January of each year, to reflect a weighted average of the current negotiated/CBA rate of the union locals from which the rate is based.

WAGE DETERMINATION APPEALS PROCESS

1.) Has there been an initial decision in the matter? This can be:

- * an existing published wage determination
- * a survey underlying a wage determination
- * a Wage and Hour Division letter setting forth a position on a wage determination matter
- * a conformance (additional classification and rate) ruling

On survey related matters, initial contact, including requests for summaries of surveys, should be with the Wage and Hour Regional Office for the area in which the survey was conducted because those Regional Offices have responsibility for the Davis-Bacon survey program. If the response from this initial contact is not satisfactory, then the process described in 2.) and 3.) should be followed.

With regard to any other matter not yet ripe for the formal process described here, initial contact should be with the Branch of Construction Wage Determinations. Write to:

Branch of Construction Wage Determinations
Wage and Hour Division
U.S. Department of Labor
200 Constitution Avenue, N.W.
Washington, DC 20210

2.) If the answer to the question in 1.) is yes, then an interested party (those affected by the action) can request

review and reconsideration from the Wage and Hour Administrator (See 29 CFR Part 1.8 and 29 CFR Part 7). Write to:

Wage and Hour Administrator
U.S. Department of Labor
200 Constitution Avenue, N.W.
Washington, DC 20210

The request should be accompanied by a full statement of the interested party's position and by any information (wage payment data, project description, area practice material, etc.) that the requestor considers relevant to the issue.

3.) If the decision of the Administrator is not favorable, an interested party may appeal directly to the Administrative Review Board (formerly the Wage Appeals Board). Write to:

Administrative Review Board
U.S. Department of Labor
200 Constitution Avenue, N.W.
Washington, DC 20210

4.) All decisions by the Administrative Review Board are final.

=====

END OF GENERAL DECISION"

PROPOSAL SCHEDULE

	ITEM	APPROX QUANTITY	UNIT	UNIT PRICE	AMOUNT
201.0000	Clearing and Grubbing	L.S.	L.S.	L.S.	\$_____
201.0100	Removal of Trees	L.S.	L.S.	L.S.	\$_____
202.0420	Removal of Guardrails	122	L.F.	\$_____	\$_____
202.0430	Removal of AC Pavement	1,837	S.Y.	\$_____	\$_____
202.0435	Removal of AC Pavement Driveways	65	S.Y.	\$_____	\$_____
202.0440	Removal of Existing Concrete Bridge and Pedestrian Walkway	L.S.	L.S.	L.S.	\$_____
202.0442	Removal of Concrete Pavement	10	S.Y.	\$_____	\$_____
202.0444	Removal of Concrete and CRM Retaining Walls	L.S.	L.S.	L.S.	\$_____
202.0446	Removal of Miscellaneous Retaining Walls and CMU Walls With Wood Fence Panels	L.S.	L.S.	L.S.	\$_____
202.0460	Removal of Riprap	25	S.Y.	\$_____	\$_____
202.0470	Removal of Pavement Striping and Markers	L.S.	L.S.	L.S.	\$_____
202.0510	Removal of 6-Inch, 8-Inch, 12-Inch and 16-Inch Water line	264	L.F.	\$_____	\$_____
202.0520	Removal of gate valves, valve boxes, reaction blocks, fire hydrants, concrete jacket, and any other waterline appurtenances and incidentals.	L.S.	L.S.	L.S.	\$_____

BR-083-1(48)

Addendum No. 1

r7/07/21

P-8

PROPOSAL SCHEDULE

	ITEM	APPROX QUANTITY	UNIT	UNIT PRICE	AMOUNT
202.0600	Removal of Cesspools and Septic Tanks	F.A.	F.A.	F.A.	\$20,000.00
202.0700	Removal of Excavated Material	L.S.	L.S.	L.S.	\$_____
202.0800	Removal of Houses	L.S.	L.S.	L.S.	\$_____
202.0910	Removal of Chain Link Fencing and Salvaging at 5-4-18:3, 5-4-11:20 and 5-4-11:21	370	L.F.	\$_____	\$_____
202.0920	Removal of Chain Link Fencing and Salvaging at 5-4-11:4	200	L.F.	\$_____	\$_____
203.0100	Roadway Excavation	600	C.Y.	\$_____	\$_____
203.0300	Borrow Excavated Material	553	C.Y.	\$_____	\$_____
204.0100	Trench Excavation for 6-inch Water line	11	C.Y.	\$_____	\$_____
204.0110	Trench Backfill for 6-inch Water line	6	C.Y.	\$_____	\$_____
204.0200	Trench Excavation for 8-inch Water line	111	C.Y.	\$_____	\$_____
204.0210	Trench Backfill for 8-inch Water line	38	C.Y.	\$_____	\$_____
204.0300	Trench Excavation for 12-Inch Water line	134	C.Y.	\$_____	\$_____
204.0310	Trench Backfill for 12-inch Water line	108	C.Y.	\$_____	\$_____

BR-083-1(48)

Addendum No. 1

r7/07/21

P-9

PROPOSAL SCHEDULE

	ITEM	APPROX QUANTITY	UNIT	UNIT PRICE	AMOUNT
204.0400	Trench Excavation for 16-inch Water line	222	C.Y.	\$ _____	\$ _____
204.0410	Trench Backfill for 16-inch Water line	171	C.Y.	\$ _____	\$ _____
205.6101	Structure Excavation for Bridge Abutment, Wingwalls, Return Wall and Barrier Walls	850	C.Y.	\$ _____	\$ _____
205.7201	Structure Backfill for Bridge Abutments, Wingwalls, Return Wall and Barrier Wall	400	C.Y.	\$ _____	\$ _____
205.8200	Filter Material	50	C.Y.	\$ _____	\$ _____
206.1000	Excavation for 4-inch Drain line	25	C.Y.	\$ _____	\$ _____
206.2000	Excavation for Dumped Riprap	700	C.Y.	\$ _____	\$ _____
209.0100	Installation, Maintenance, Monitoring, and Removal of BMP	L.S.	L.S.	L.S.	\$ _____
209.0200	Additional Water Pollution, Dust, and Erosion Control	F.A.	F.A.	F.A.	\$ 175,000.00
209.0300	Water Quality Sampling	L.S.	L.S.	L.S.	\$ _____
219.1000	Determination and Characterization of Fill Material	L.S.	L.S.	L.S.	\$ _____
301.1000	Hot Mix Asphalt Base Course	130	C.Y.	\$ _____	\$ _____
304.1000	Aggregate Base	115	C.Y.	\$ _____	\$ _____

BR-083-1(48)

Addendum No. 1

r7/07/21

P-10

PROPOSAL SCHEDULE

	ITEM	APPROX QUANTITY	UNIT	UNIT PRICE	AMOUNT
305.1000	Aggregate Subbase	310	C.Y.	\$ _____	\$ _____
401.1000	HMA Pavement, Mix No. IV	392	TON	\$ _____	\$ _____
401.2000	Pavement Smoothness Incentive	Allowance	Allowance	Allowance	\$ 2,700.00
411.0100	6-Inch Concrete Pavement	16	C.Y.	\$ _____	\$ _____
503.1091	Concrete for Abutments, Wingwalls, Return Wall and Barrier Walls	300	C.Y.	\$ _____	\$ _____
503.1093	Concrete for Bridge Deck, Topping over End Beam and Concrete encasing ducts with bridge	280	C.Y.	\$ _____	\$ _____
503.1095	Concrete for Approach Slabs and Sleeper Slabs	140	C.Y.	\$ _____	\$ _____
503.1096	Concrete for W16 Cradles	5	C.Y.	\$ _____	\$ _____
503.1097	Concrete for Diaphragms	20	C.Y.	\$ _____	\$ _____
503.1099	Concrete for Reaction Blocks at Wing Wall No. 3 and No. 4	30	C.Y.	\$ _____	\$ _____
503.2050	Concrete for Reaction Blocks, Test Blocks, Jackets and Reaction Beams	122	C.Y.	\$ _____	\$ _____
503.8000	Mechanical Grooving	6,500	S.F.	\$ _____	\$ _____
504.7400	Precast Prestressed Concrete Girder	1,227	L.F.	\$ _____	\$ _____

BR-083-1(48)

Addendum No. 1

r7/07/21

P-11

PROPOSAL SCHEDULE

	ITEM	APPROX QUANTITY	UNIT	UNIT PRICE	AMOUNT
504.7401	Inspections in a State other than Hawaii	F.A.	F.A.	F.A.	\$ 100,000.00
507.1501	Metal Railing	231	L.F.	\$ _____	\$ _____
507.7000	Concrete Barrier (Including End Posts)	280	L.F.	\$ _____	\$ _____
507.7001	Aesthetic Bridge Railing (Including End Posts)	231	L.F.	\$ _____	\$ _____
511.0100	Furnishing Drilled Shaft Drilling Equipment	L.S.	L.S.	L.S.	\$ _____
511.0200	Obstructions	120	Hour	\$ _____	\$ _____
511.0300	Load Test	1	EA	\$ _____	\$ _____
511.0310	Trial Shaft	100	LF	\$ _____	\$ _____
511.0400	Drilled Shaft (48-Inch Diameter)	600	LF	\$ _____	\$ _____
511.0510	Unclassified Shaft Excavation (48-Inch Diameter)	600	LF	\$ _____	\$ _____
511.1100	Coring for Integrity Testing for Acceptable Drilled Shaft	154	LF	\$ _____	\$ _____
512.0200	Installing Prefabricated Steel Beam Bridge Abutments and Piers	1	EA	\$ _____	\$ _____
512.0300	Installing Prefabricated Steel Beam Bridge	1	EA	\$ _____	\$ _____

BR-083-1(48)

Addendum No. 1

r7/07/21

P-12

PROPOSAL SCHEDULE

	ITEM	APPROX QUANTITY	UNIT	UNIT PRICE	AMOUNT
512.0500	Removal of Prefabricated Steel Beam Bridge, Prefabricated Steel Beam Bridge Abutments and Piers	1	EA	\$ _____	\$ _____
540.1000	VESLMC (Bridge Deck Closure)	10	C.Y.	\$ _____	\$ _____
540.1001	VESLMC (End Beam Closures)	5	C.Y.	\$ _____	\$ _____
602.1091	Reinforcing Steel for Abutments, Wingwalls, Return Wall and Barrier Walls	80,000	LBS	\$ _____	\$ _____
602.1093	Reinforcing Steel for Bridge Deck, Topping over End Beam and Concrete encasing ducts with bridge	85,000	LBS	\$ _____	\$ _____
602.1095	Reinforcing Steel for Approach Slabs and Sleeper Slabs	48,000	LBS	\$ _____	\$ _____
602.1097	Reinforcing Steel for Diaphragms	7,000	LBS	\$ _____	\$ _____
602.1099	Reinforcing Steel for Reaction Blocks	4,000	LBS	\$ _____	\$ _____
602.1100	Reinforcing Steel (Epoxy Coated) for Corbels	600	LBS	\$ _____	\$ _____
603.1000	Bed Course Material for Culvert	10	C.Y.	\$ _____	\$ _____
603.2000	4-Inch High Density Polyethylene Pipe, Type S	70	L.F.	\$ _____	\$ _____
606.3000	Guardrail Type MGS with Standard 8" Offset Block	175	L.F.	\$ _____	\$ _____
607.0140	6-Feet, Chain Link Fence	55	L.F.	\$ _____	\$ _____

BR-083-1(48)

Addendum No. 1

r7/07/21

P-13

PROPOSAL SCHEDULE

	ITEM	APPROX QUANTITY	UNIT	UNIT PRICE	AMOUNT
607.0150	8-Feet, Chain Link Fence With Barbed Wire	610	L.F.	\$ _____	\$ _____
607.0160	Chain Link Gate, 8 Feet High and 20 feet Wide	2	Each	\$ _____	\$ _____
614.0100	Adjusting Street Survey Monuments	1	Each	\$ _____	\$ _____
617.1000	Imported Planting Soil	64	C.Y.	\$ _____	\$ _____
621.1000	Security Guard Services	L.S.	L.S.	L.S.	\$ _____
621.1100	Rodent Control	L.S.	L.S.	L.S.	\$ _____
622.1000	Highway Lighting Luminaire and Bracket Arm, 84W LED	4	Each	\$ _____	\$ _____
622.8000	Temporary Highway Lighting	L.S.	L.S.	L.S.	\$ _____
624.1003	Temporary Water Systems	L.S.	L.S.	L.S.	\$ _____
624.1004	Permanent Water Systems	L.S.	L.S.	L.S.	\$ _____
626.1000	Type A Manhole, 3.0 feet to 4.0 feet	1	Each	\$ _____	\$ _____
626.1100	Type A Manhole, 4.0 feet to 5.0 feet	1	Each	\$ _____	\$ _____
626.3100	6-Inch Standard Valve Box	1	Each	\$ _____	\$ _____

BR-083-1(48)

Addendum No. 1

r7/07/21

P-14

PROPOSAL SCHEDULE

	ITEM	APPROX QUANTITY	UNIT	UNIT PRICE	AMOUNT
626.3200	8-Inch Standard Valve Box	2	Each	\$ _____	\$ _____
627.1000	Lightweight Concrete	10	C.Y.	\$ _____	\$ _____
628.0100	Shotcrete for Stream Lining	L.S.	L.S.	L.S.	\$ _____
629.1010	4-Inch Pavement Striping (Thermoplastic) (Diversion Road)	3,419	L.F.	\$ _____	\$ _____
629.1012	4-Inch Pavement Striping (Thermoplastic) (Final)	2,163	L.F.	\$ _____	\$ _____
629.1014	8-Inch Pavement Striping (Thermoplastic) (Diversion Road)	25	L.F.	\$ _____	\$ _____
629.1016	12-Inch Pavement Striping (Thermoplastic) (Diversion Road)	14	L.F.	\$ _____	\$ _____
629.1018	12-Inch Pavement Striping (Thermoplastic) (Final)	17	L.F.	\$ _____	\$ _____
629.1020	Pavement Arrow (Thermoplastic) (Diversion Road)	1	Each	\$ _____	\$ _____
629.1022	Pavement Word (Thermoplastic) (Diversion Road)	2	Each	\$ _____	\$ _____
629.2010	Type C Pavement Marker	54	Each	\$ _____	\$ _____
629.2020	Type D Pavement Marker	58	Each	\$ _____	\$ _____
631.3000	New "No Jumping From Bridge" Sign	4	Each	\$ _____	\$ _____

BR-083-1(48)

Addendum No. 1

r7/07/21

P-15

PROPOSAL SCHEDULE

	ITEM	APPROX QUANTITY	UNIT	UNIT PRICE	AMOUNT
631.4000	New "Unlawful to Litter \$1000 Fine" Sign	2	Each	\$ _____	\$ _____
631.5000	New "The Bus" Sign	1	Each	\$ _____	\$ _____
631.6000	New Stop and Street Sign	1	Each	\$ _____	\$ _____
631.7000	New "No Parking" and Supplemental Signs	2	Each	\$ _____	\$ _____
631.8001	Relocation of Existing Bus Stop Sign	1	Each	\$ _____	\$ _____
631.8002	Relocation of Existing Street Sign	2	Each	\$ _____	\$ _____
631.8003	Relocation of Existing Stop Sign	1	Each	\$ _____	\$ _____
632.1000	Type OM 3-1 Object Marker With Post	4	Each	\$ _____	\$ _____
636.1000	E-Construction license	F.A.	F.A.	F.A.	\$ 234,800.00
641.1000	Hydro-mulch seeding (Seashore Paspalum)	580	S.Y.	\$ _____	\$ _____
642.1000	Plant Maintenance	3	Month	\$ _____	\$ _____
643.1000	Maintenance of Existing Landscape Areas	F.A.	F.A.	F.A.	\$ 70,000.00
645.1000	Traffic Control	L.S.	L.S.	L.S.	\$ _____

BR-083-1(48)

Addendum No. 1

r7/07/21

P-16

PROPOSAL SCHEDULE

	ITEM	APPROX QUANTITY	UNIT	UNIT PRICE	AMOUNT
645.2000	Additional Police Officers, Additional Traffic Control Devices and Advertisements	F.A.	F.A.	F.A.	\$ 100,000.00
648.1000	Field Posted Drawings	L.S.	L.S.	L.S.	\$ _____
651.1000	HECO Ductline, One 3-Inch PVC, Schedule 40, Concrete Encased	L.S.	L.S.	L.S.	\$ _____
651.2000	HECO Handhole, 2' x 4'	1	Each	\$ _____	\$ _____
651.3001	HECO Pole Riser, One 3-Inch	4	Each	\$ _____	\$ _____
651.3005	Remove HECO Pole Riser	4	Each	\$ _____	\$ _____
652.1001	HT Ductline, One 2-Inch, Type GT 42, Concrete Encased	L.S.	L.S.	L.S.	\$ _____
652.1002	HT Ductline, One 1-Inch, Type GT 42, Concrete Encased	L.S.	L.S.	L.S.	\$ _____
652.1008	JTS Ductline, Two 4-Inch, PVC Schedule 40, Concrete Encased	L.S.	L.S.	L.S.	\$ _____
652.1009	JTS Conduit In Bridge Structure, Two 4-Inch, PVC Schedule 40	L.S.	L.S.	L.S.	\$ _____
652.2001	HT Handhole, 2' x 4'	1	Each	\$ _____	\$ _____
652.2005	JTS Manhole, 4' x 6'	2	Each	\$ _____	\$ _____
652.3001	HT Pole Riser, One 2-Inch	2	Each	\$ _____	\$ _____

BR-083-1(48)

Addendum No. 1

r7/07/21

P-17

PROPOSAL SCHEDULE

	ITEM	APPROX QUANTITY	UNIT	UNIT PRICE	AMOUNT
652.3002	HT Pole Riser, One 1-Inch	2	Each	\$ _____	\$ _____
652.3005	Remove HT Pole Riser	5	Each	\$ _____	\$ _____
655.0100	Dumped Riprap	700	C.Y.	\$ _____	\$ _____
657.1000	Handling and Disposal of Hazardous Items and Material from Existing Bridge and Pedestrian Walkway	F.A.	F.A.	F.A.	\$ 20,000.00
657.2000	Handling and Disposal of Hazardous Excavated Items and Material	F.A.	F.A.	F.A.	\$ 20,000.00
665.1000	Pest Control	L.S.	L.S.	L.S.	\$ _____
688.1000	Asbestos Removal	L.S.	L.S.	L.S.	\$ _____
688.2000	Additional Asbestos Removal	F.A.	F.A.	F.A.	\$ 5,000.00
688.3000	Asbestos Removal Monitoring	F.A.	F.A.	F.A.	\$ 10,000.00
691.1000	Archaeological Monitoring	F.A.	F.A.	F.A.	\$ 100,000.00
693.1000	Terminal Impact Attenuator - Quadguard	3	Each	\$ _____	\$ _____
693.2000	Terminal Impact Attenuator - Crash Cushion System	1	Each	\$ _____	\$ _____
693.3000	Terminal Impact Attenuator - Quadguard (Diversion Road)	4	Each	\$ _____	\$ _____

BR-083-1(48)

Addendum No. 1

r7/07/21

P-18

PROPOSAL SCHEDULE

	ITEM	APPROX QUANTITY	UNIT	UNIT PRICE	AMOUNT
693.4000	Terminal Impact Attenuator - Crash Cushion System (Diversion Road)	2	Each	\$ _____	\$ _____
695.1000	Public Education Materials or Services	F.A.	F.A.	F.A.	\$ 50,000.00
696.0200	Field Office Trailer (Not to Exceed \$32,000)	L.S.	L.S.	L.S.	\$ _____
696.1000	Project Site Laboratory Trailer (Not to Exceed \$22,000)	L.S.	L.S.	L.S.	\$ _____
696.2000	Maintenance of Trailers	F.A.	F.A.	F.A.	\$ 80,000.00
699.1000	Mobilization (Not to Exceed 6% of the Sum of All Items Excluding the Bid Price of This Item).	L.S.	L.S.	L.S.	\$ _____
TOTAL AMOUNT FOR COMPARISON OF BIDS					\$ _____
<p>NOTES:</p> <ol style="list-style-type: none"> 1. Bids shall include all Federal, State, County and other applicable taxes. 2. The TOTAL AMOUNT FOR COMPARISON OF BIDS will be used to determine the lowest responsible bidder. 3. In case of a discrepancy between unit price and the total in said bid, the unit price shall prevail. 4. Bidders must complete all unit prices and amounts. Failure to do so may be grounds for rejection of bid. 					

FED. ROAD DIST. NO.	STATE	PROJ. NO.	FISCAL YEAR	SHEET NO.	TOTAL SHEETS
HAWAII	HAW.	BR-083-1(48)	2021	14	161

(* Note:
New R/W begins at Sta. 1246+52.78.
See sht. C-17.

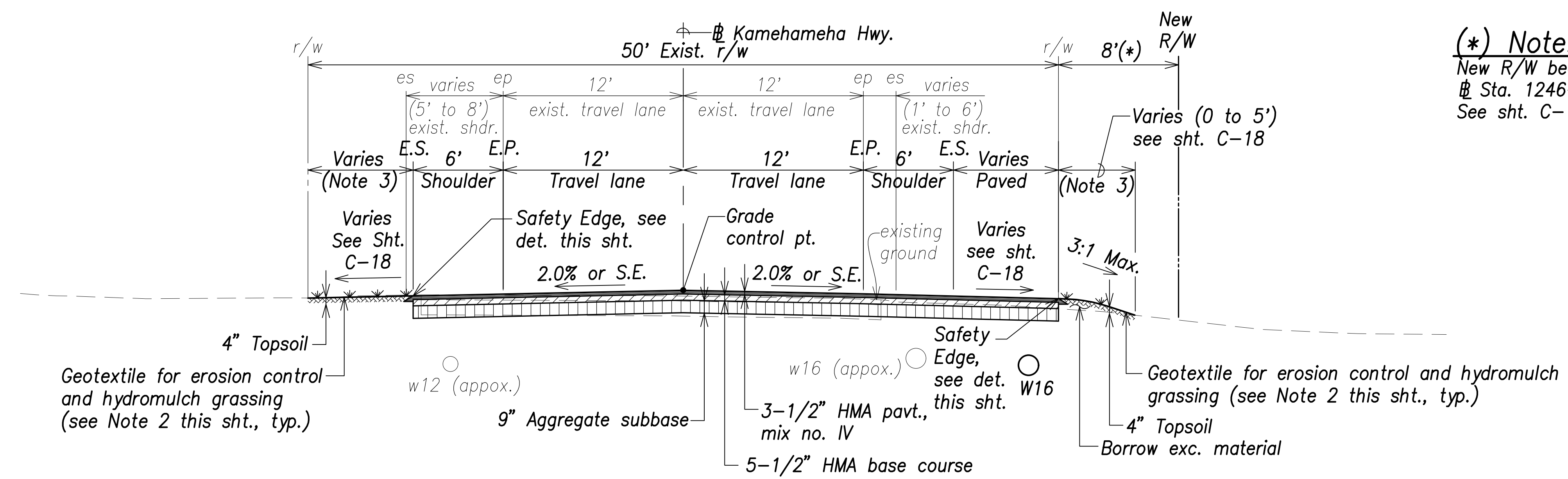

TYPICAL SECTION - (Sta. 1246+15 to Sta. 1246+70)
Scale: 1"=5'

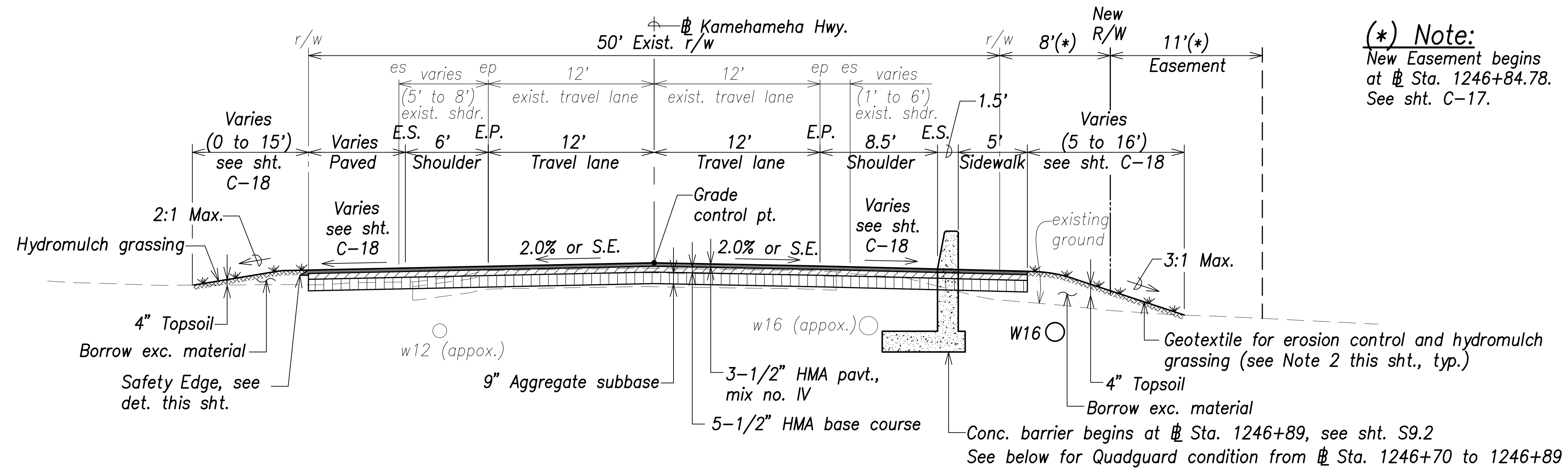

TYPICAL SECTION - (Sta. 1246+70 to Sta. 1247+12.18)
Scale: 1"=5'

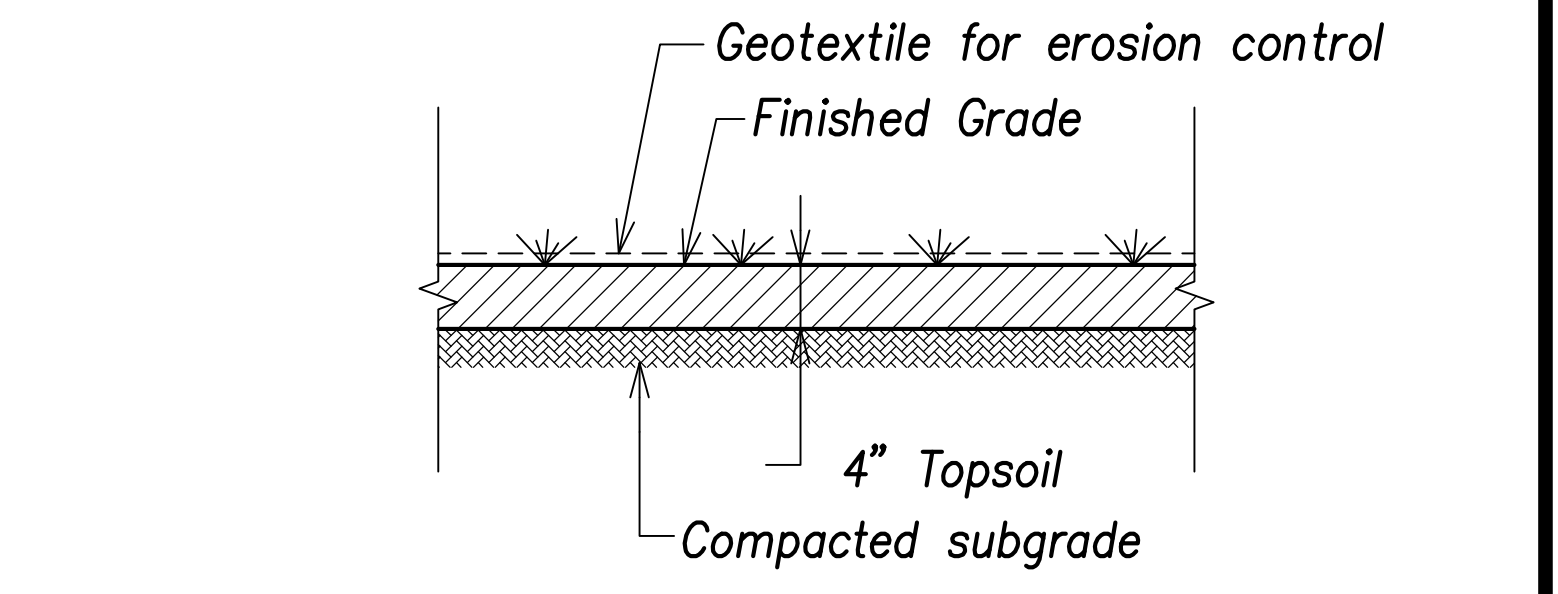

GEOTEXTILE FOR EROSION CONTROL
Not to Scale

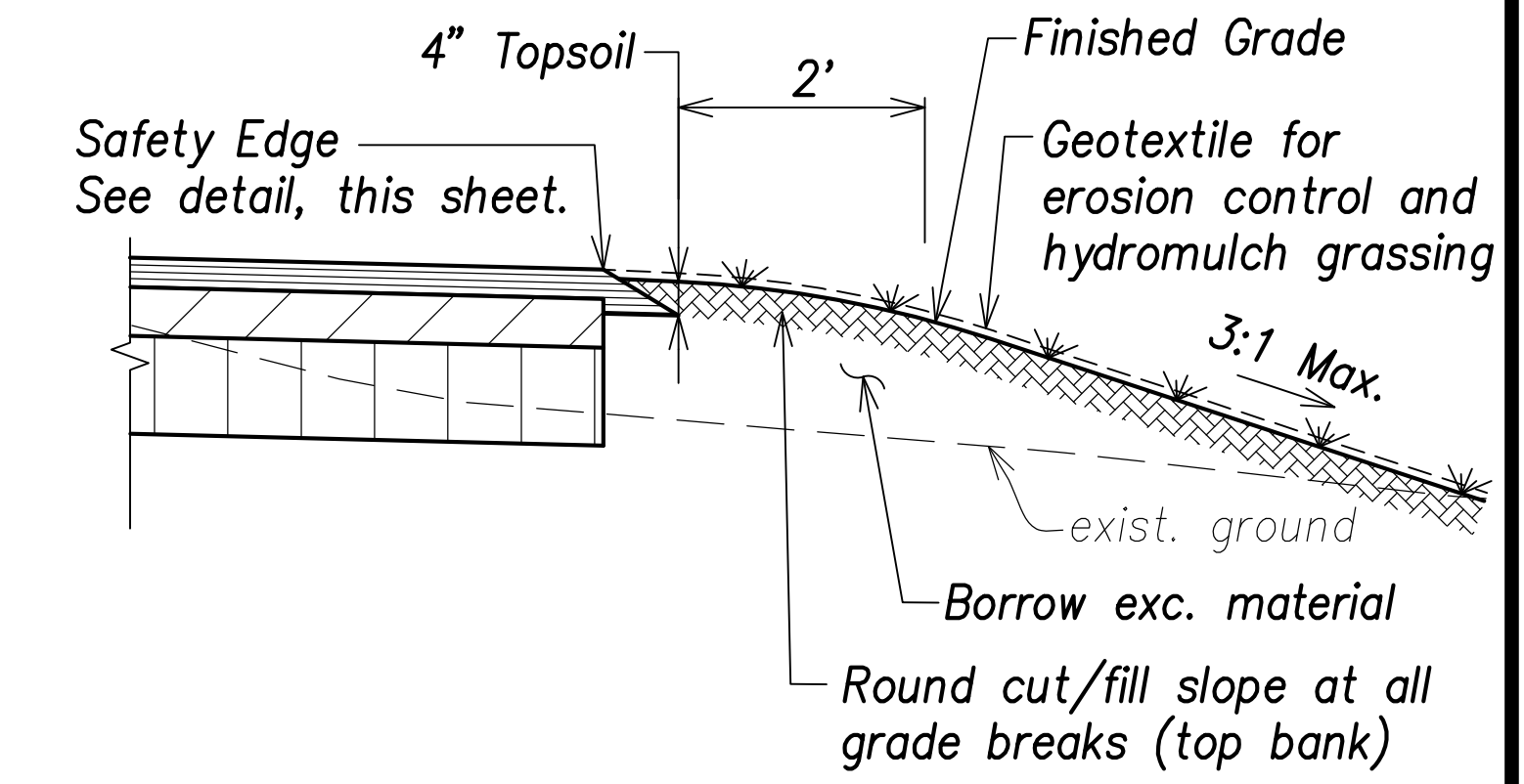

TYPICAL TOP BANK ROUNDING
Not to Scale

(* Note:
New Easement begins at Sta. 1246+84.78.
See sht. C-17.

Notes:

1. The Contractor shall photo document the existing landscaping in all adjacent residential lots affected by the project and submit to the engineer. Upon completion of major work items, the Contractor shall restore landscaping back to existing condition or better.
2. Hydromulch Grassing. The Contractor shall broadcast sprigs of seashore paspalum at 10 bushels per 1,000 SF capped with hydromulch at 30 lbs per 1,000 SF.
3. At driveway connections, pavement section shall be 3-1/2" HMA pavt., mix no. IV over 6" Aggregate subbase. See sht. C-17 and C-20.

DATE	BY
DESIGNED BY	WC
TRACED BY	WC
QUANTITIES BY	
CHECKED BY	
NO.	

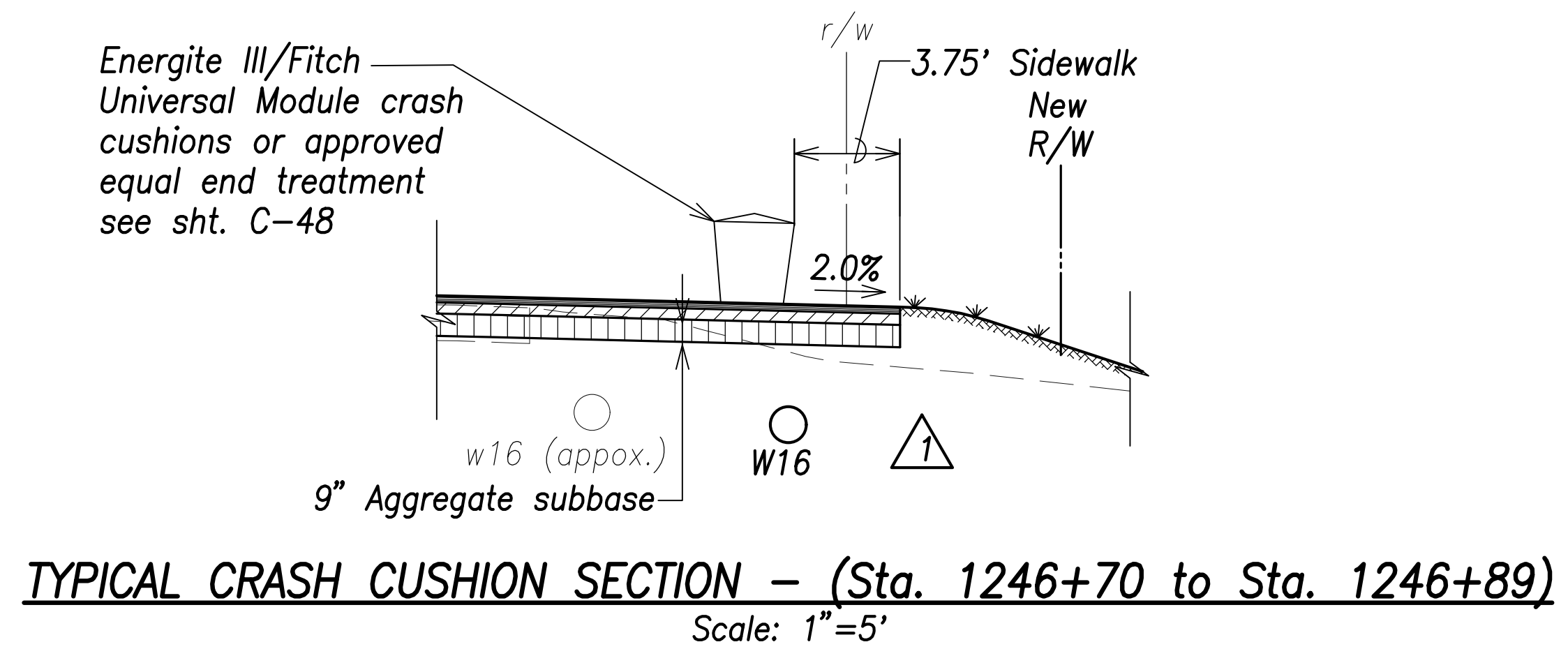

TYPICAL CRASH CUSHION SECTION - (Sta. 1246+70 to Sta. 1246+89)
Scale: 1"=5'

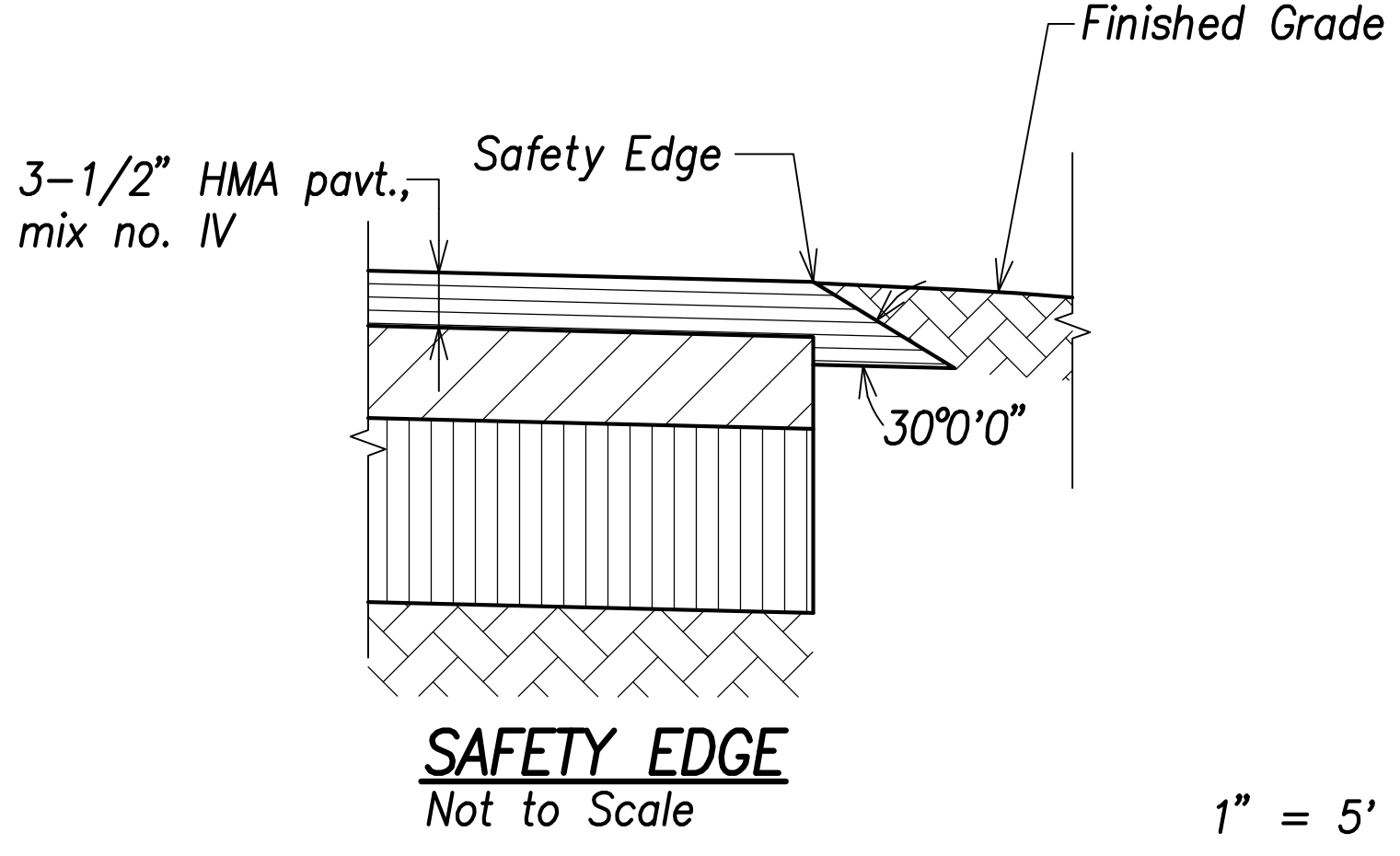

SAFETY EDGE
Not to Scale

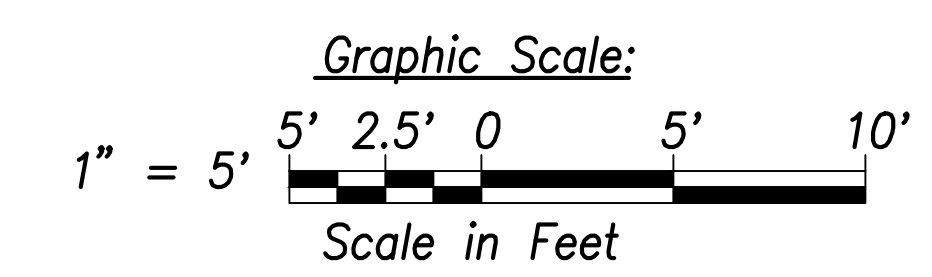

7/7/21	Rev. Typ. Crash Cushion Section
DATE	REVISION



STATE OF HAWAII
DEPARTMENT OF TRANSPORTATION
HIGHWAYS DIVISION

TYPICAL SECTIONS - 1

Kamehameha Highway
Kaipapau Stream Bridge Replacement
Federal Aid Project No. BR-083-1(48)

Scale: As Noted Date: February 2021

FED. ROAD DIST. NO.	STATE	PROJ. NO.	FISCAL YEAR	SHEET NO.	TOTAL SHEETS
HAWAII	HAW.	BR-083-1(48)	2021	20	161

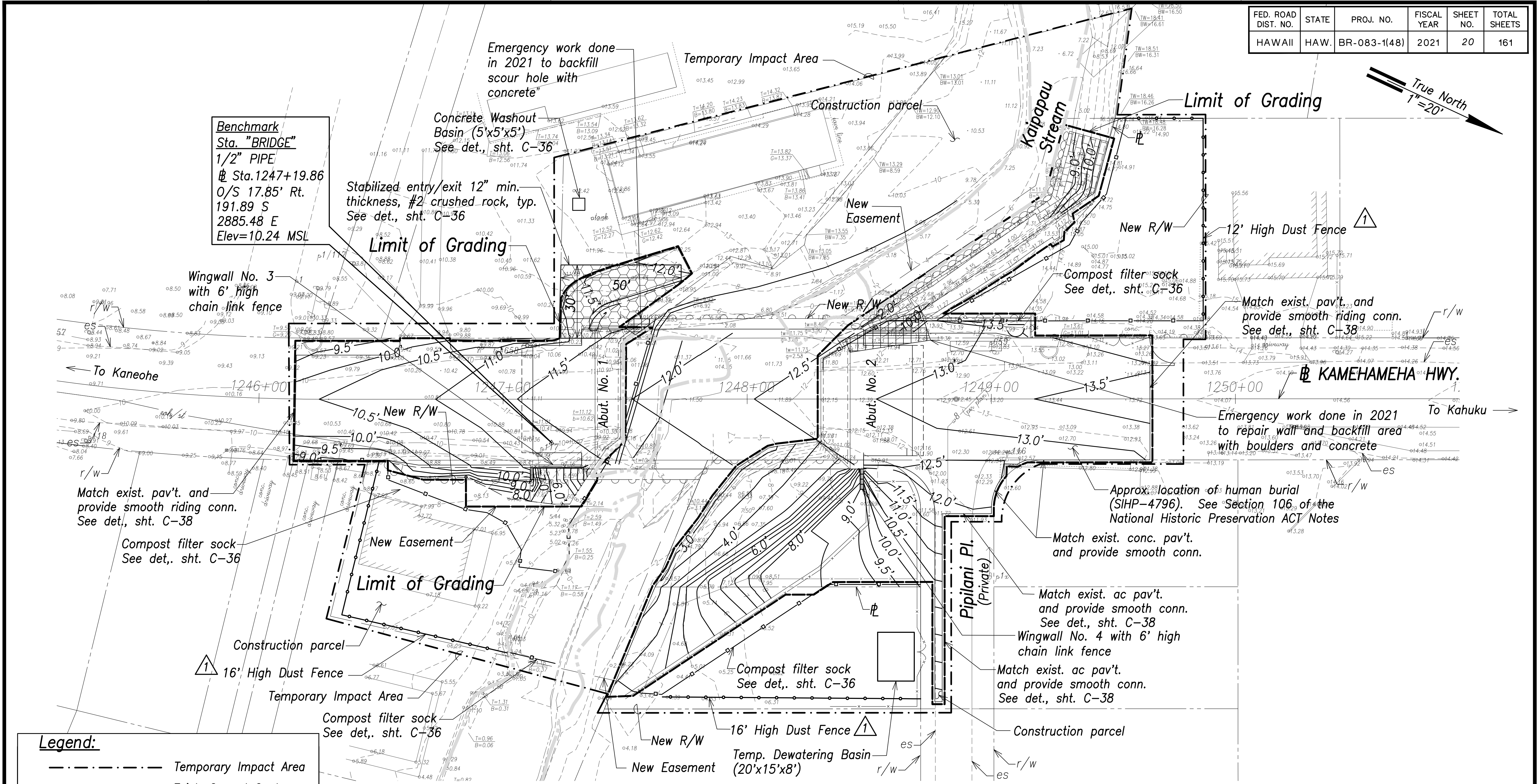

Benchmark
Sta. "BRIDGE"
1/2" PIPE
Sta. 1247+19.86
O/S 17.85' Rt.
191.89 S
2885.48 E
Elev=10.24 MSL

Wingwall No. 3
with 6' high
chain link fence

Match exist. pav't. and
provide smooth riding conn.
See det., sht. C-38

Compost filter sock
See det., sht. C-36

16' High Dust Fence

Compost filter sock
See det., sht. C-36

New R/W

New Easement

Temp. Dewatering Basin
(20'x15'x8')

Pipilani Pl.
(Private)

Match exist. conc. pav't.
and provide smooth conn.

Match exist. ac pav't.
and provide smooth conn.
See det., sht. C-38

Wingwall No. 4 with 6' high
chain link fence

Match exist. ac pav't.
and provide smooth conn.
See det., sht. C-38

Construction parcel

Match exist. pav't. and
provide smooth riding conn.
See det., sht. C-38

Emergency work done in 2021
to repair wall and backfill area
with boulders and concrete

Approx. location of human burial
(SIHP-4796). See Section 106 of the
National Historic Preservation Act Notes

Legend:

- - - - - Temporary Impact Area
- - - - - 10 - - - - - Exist. Ground Contour
- - - - - 10 - - - - - Finished Grade Contour
- - - - - Limit of Grading
- - - - - Dust Fence
- - - - - Compost Filter Sock
- - - - - Top of Bank
- - - - - Bottom of Bank
- ← - - - - - Drainage Flow Direction
- - - - - - Stabilized Entry/Exit

Fill Condition Cut Condition

Notes:

- For additional finished grade elevations, see sht. C-20.
- For bridge deck elevations, see structural drawings.
- For grading work under bridge, see sht. C-19.
- The contractor shall be responsible for obtaining grading permit from the City and County of Honolulu, Department of Planning and Permitting.
- Sediment and Erosion Control BMP measures shown in the Contract Documents are minimum BMPs requirements and do not constitute an acceptable and/or complete Sediment and Erosion Control Plan. The Contractor shall incorporate additional BMPs based upon their means and methods considering site conditions and construction sequence in accordance with the Contract Documents including applicable permit document requirements. Cost shall be included in Pay Item 209.0100, "Installation, Maintenance, Monitoring, and Removal of BMP."

ROADWAY GRADING, EROSION & SEDIMENT CONTROL PLAN
Scale: 1"=20'

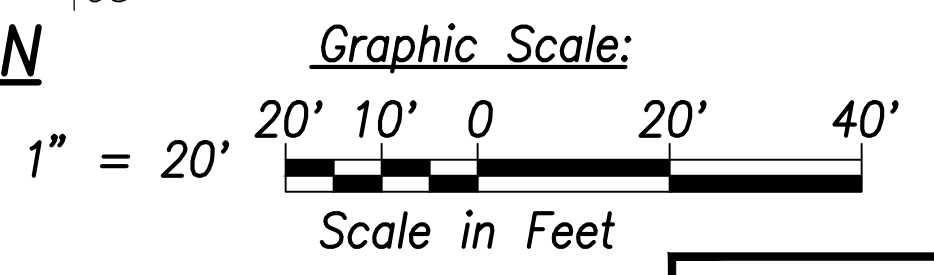

DATE	BY
DESIGNED BY	
CHECKED BY	

WALTER G. CHONG
LICENSED PROFESSIONAL ENGINEER
No. 8982-C
HAWAII, U.S.A.

SIGNATURE: *Walter G. Chong* LIC. EXPIRATION: 4/30/22
R. M. TOWILL CORPORATION

DATE	REVISION
7/7/21	Rev. Dust fence heights

STATE OF HAWAII
DEPARTMENT OF TRANSPORTATION
HIGHWAYS DIVISION
ROADWAY GRADING, EROSION & SEDIMENT CONTROL PLAN
Kamehameha Highway
Kaipapau Stream Bridge Replacement
Federal Aid Project No. BR-083-1(48)
Scale: As Noted Date: February 2021

FED. ROAD DIST. NO.	STATE	PROJ. NO.	FISCAL YEAR	SHEET NO.	TOTAL SHEETS
HAWAII	HAW.	BR-083-1(48)	2021	26	161

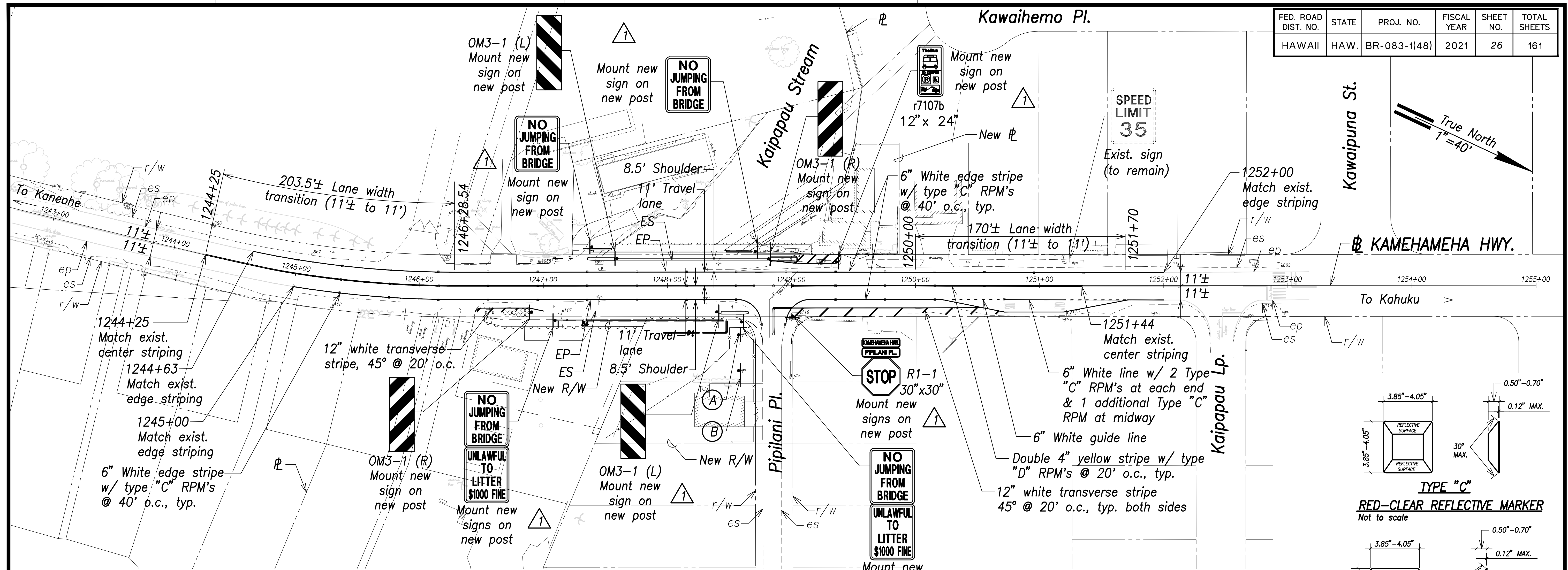

SIGNING & STRIPING PLAN
Scale: 1"=40'

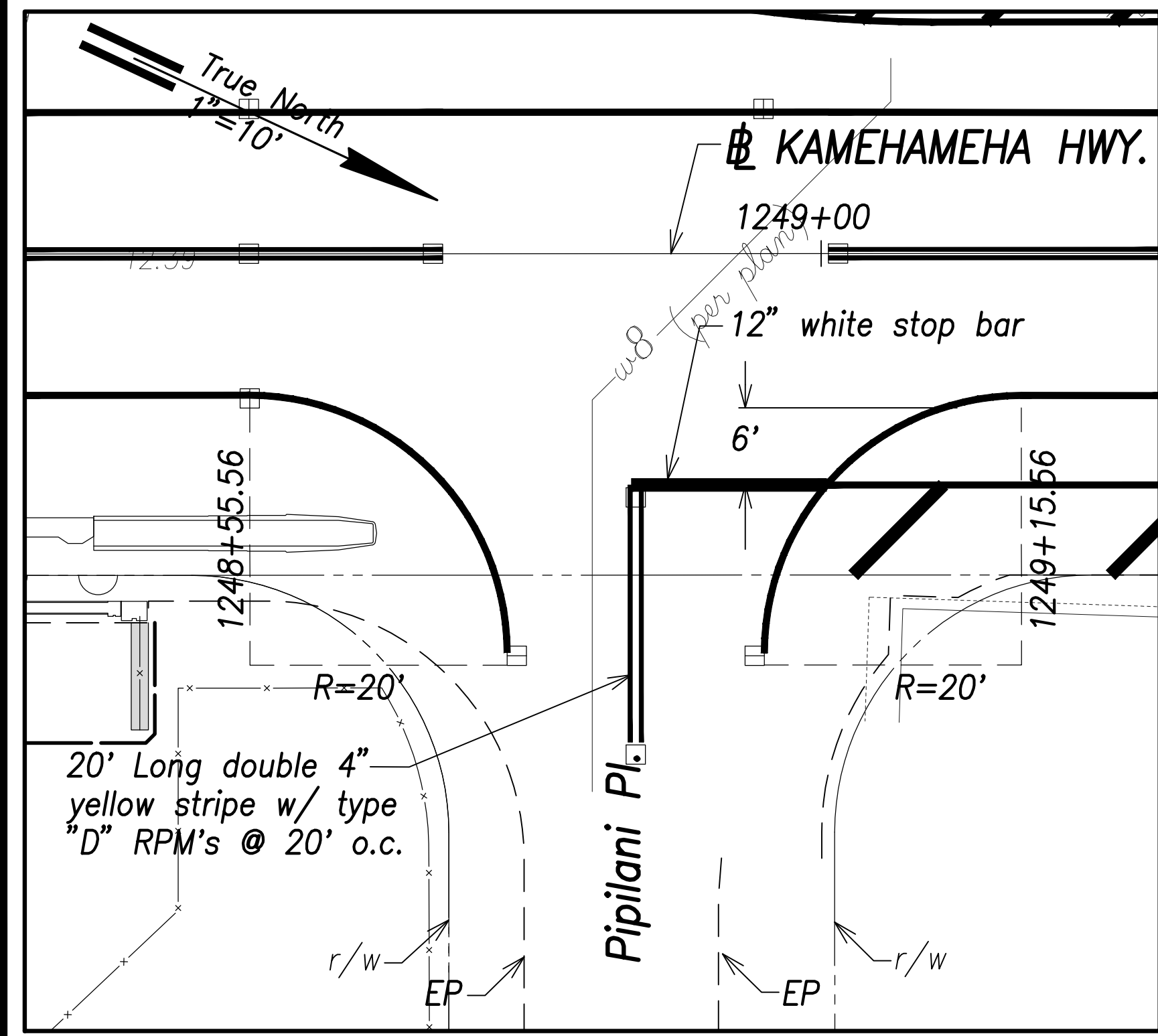

INTERSECTION PLAN
Scale: 1"=10'

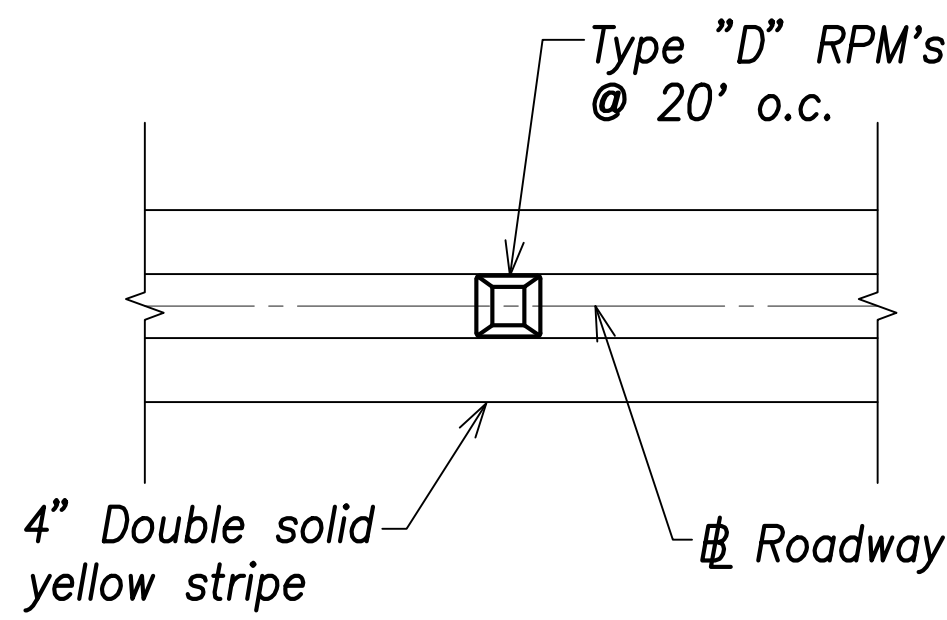

TYPICAL CENTER LINE STRIPING
Not to scale

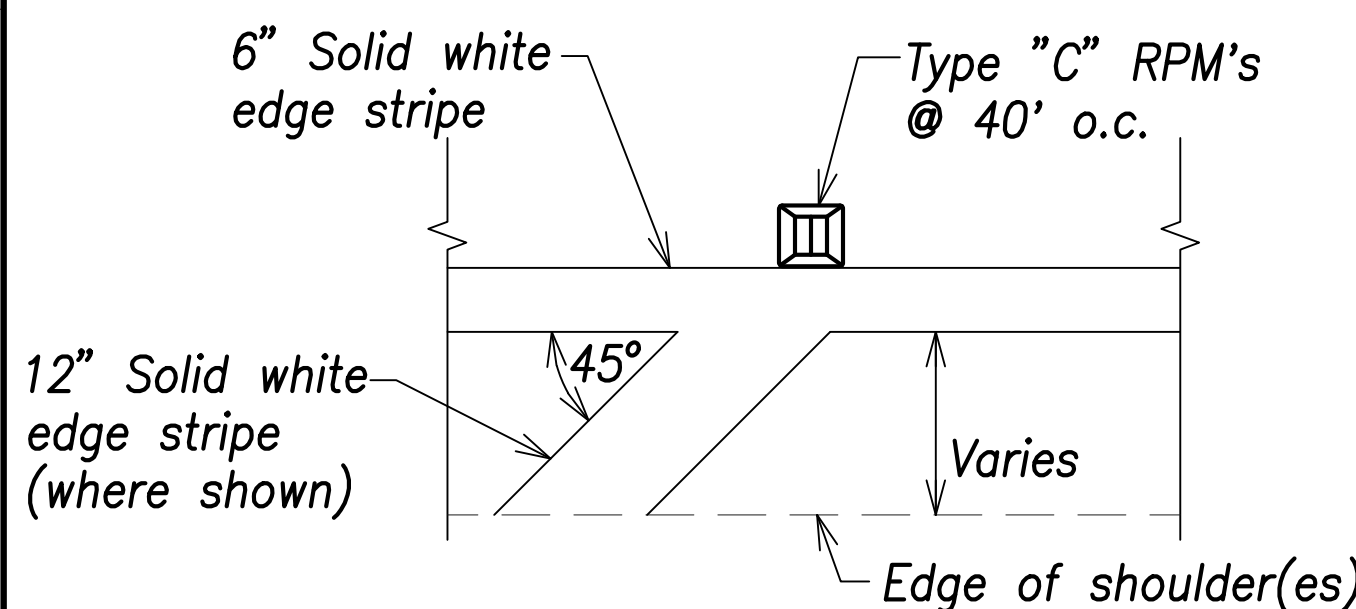

TYPICAL EDGE LINE STRIPING
Not to scale

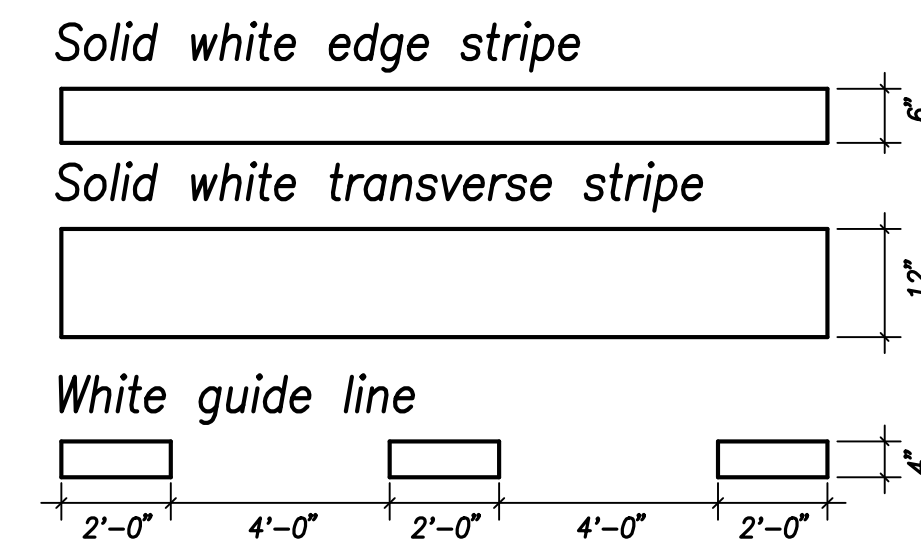

TYPES OF LONGITUDINAL LINES
Not to scale

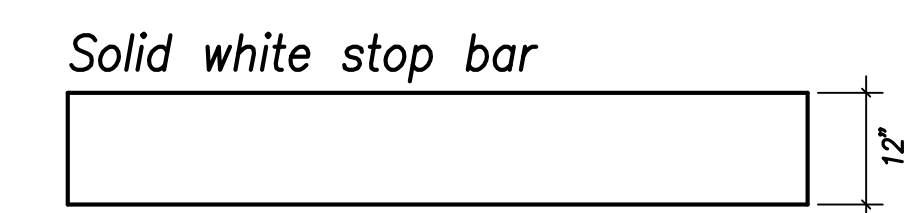

STOP BAR DETAIL
Not to scale

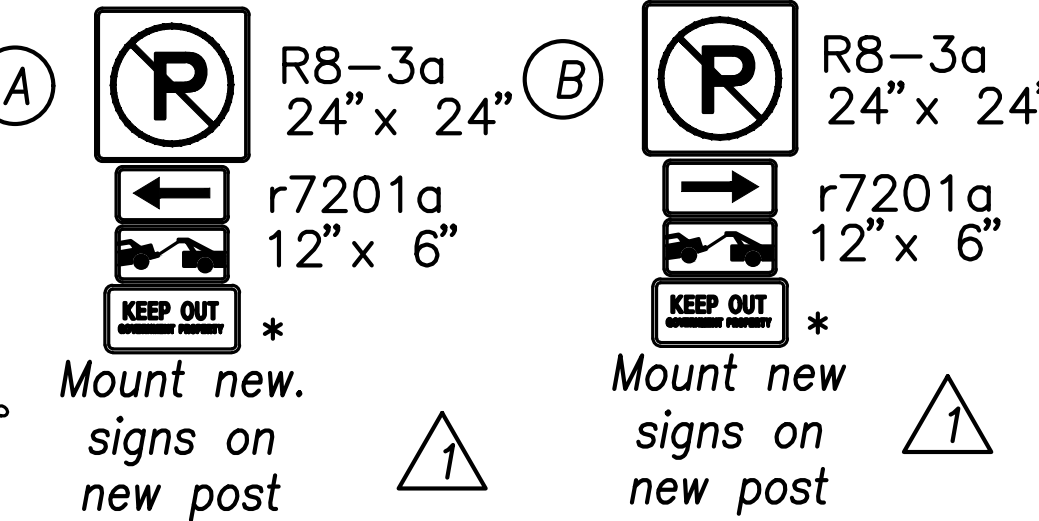

*See Sheet C-41 for sign detail

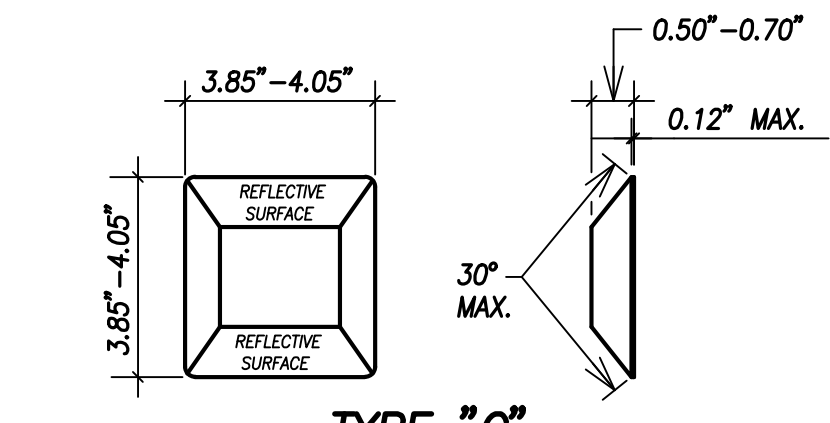

TYPE "C" RED-CLEAR REFLECTIVE MARKER
Not to scale

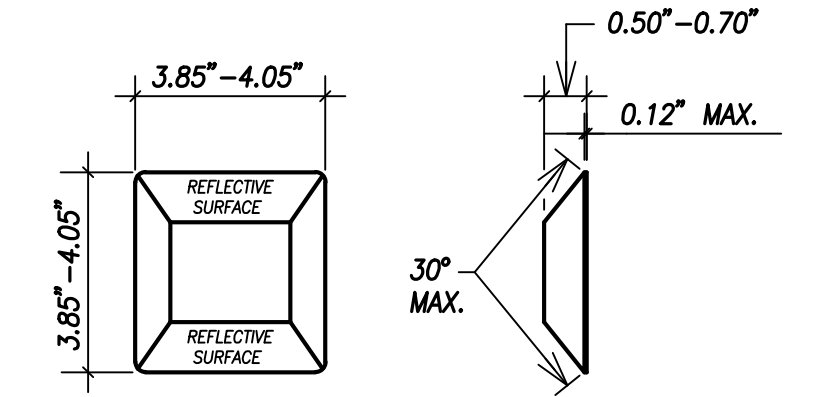

TYPE "D" TWO-WAY YELLOW REFLECTIVE MARKER
Not to scale

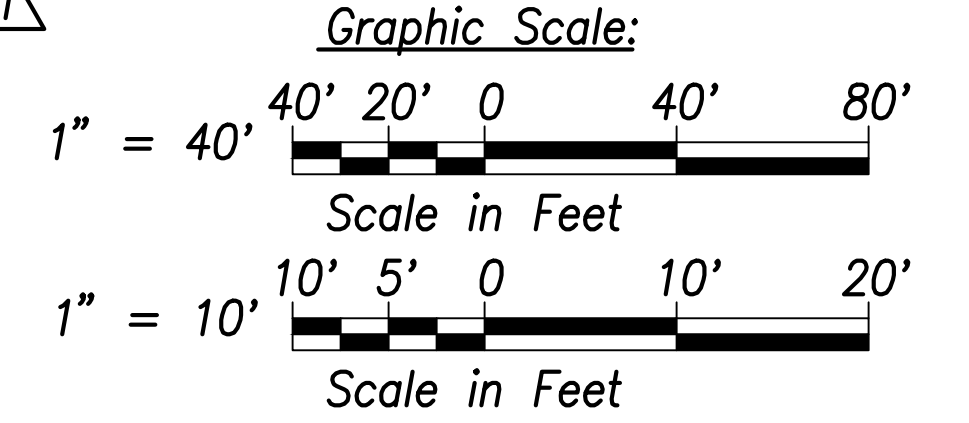

DATE	BY
DESIGNED BY	WC
TRACED BY	WC
QUANTITIES BY	
CHECKED BY	
ORIGINAL PLAN	
NOTE BOOK	
No.	

WALTER G. C. CHONG
LICENSED PROFESSIONAL ENGINEERS
No. 8982-C
HAWAII, U.S.A.
4/30/22
R. M. TOWILL CORPORATION

DATE	REVISION
7/7/21	Rev. sign callouts

STATE OF HAWAII
DEPARTMENT OF TRANSPORTATION
HIGHWAYS DIVISION
SIGNING & STRIPING PLAN
Kamehameha Highway
Kaipapau Stream Bridge Replacement
Federal Aid Project No. BR-083-1(48)
Scale: As Noted Date: February 2021

FED. ROAD DIST. NO.	STATE	PROJ. NO.	FISCAL YEAR	SHEET NO.	TOTAL SHEETS
HAWAII	HAW.	BR-083-1(48)	2021	31	161

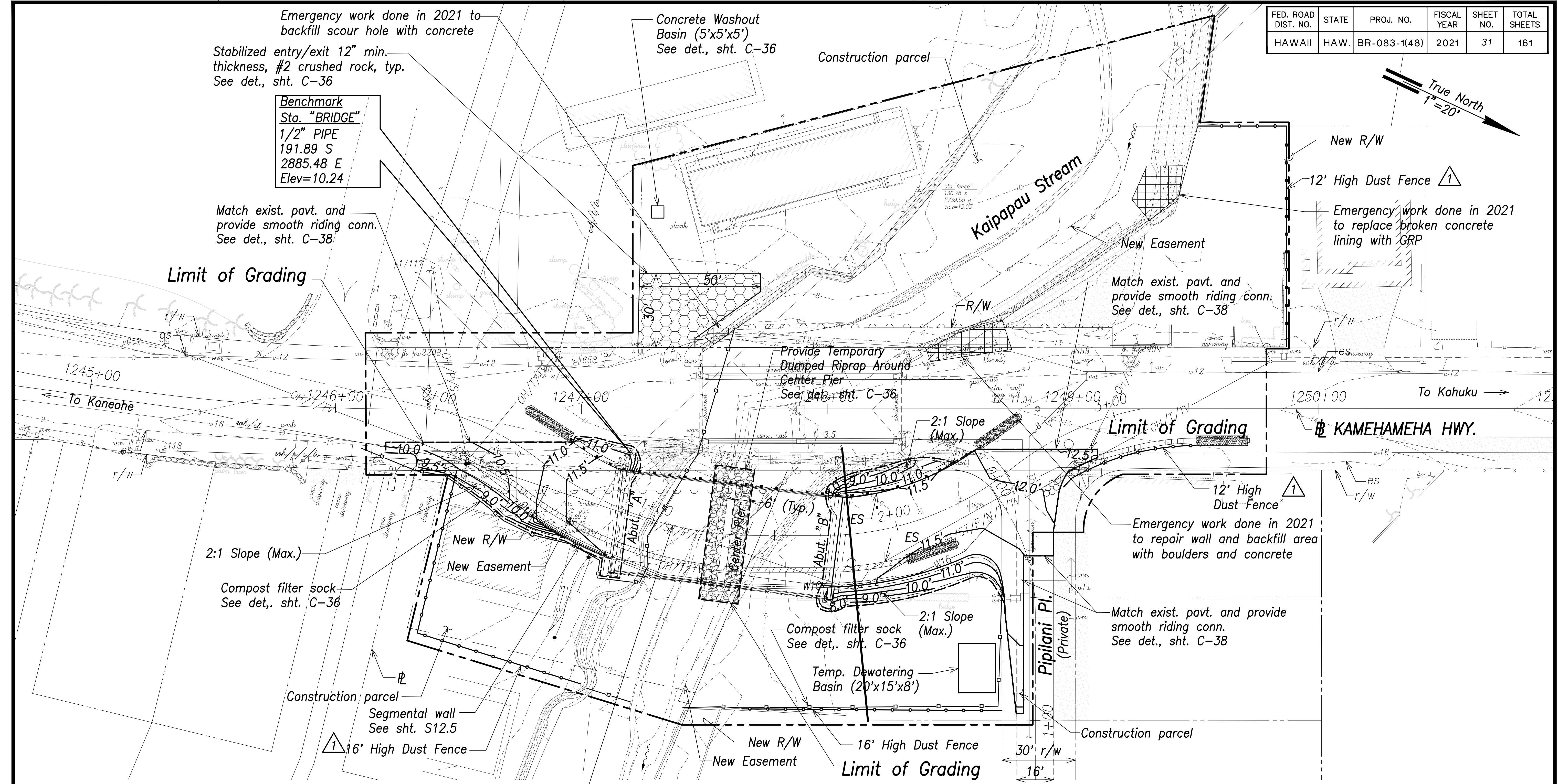

Legend:

	Project Limits
	10' Exist. Ground Contour
	10.0' Finished Grade Contour
	Limit of Grading
	Dust Fence
	Compost Filter Sock
	Drainage Flow Direction
	Stabilized Entry/Exit

Notes:

- The contractor shall be responsible for obtaining grading permit from the City and County of Honolulu, Department of Planning and Permitting.
- Sediment and Erosion Control BMP measures shown in the Contract Documents are minimum BMPs requirements and do not constitute an acceptable and/or complete Sediment and Erosion Control Plan. The Contractor shall incorporate additional BMPs based upon their means and methods considering site conditions and construction sequence in accordance with the Contract Documents including applicable permit document requirements. Cost shall be included in Pay Item 209.0100, "Installation, Maintenance, Monitoring, and Removal of BMP."

DIVERSION ROAD - GRADING, EROSION AND SEDIMENT CONTROL PLAN
Scale: 1"=20'

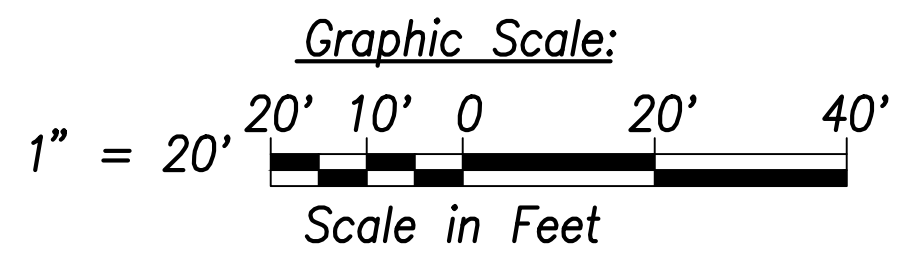

DATE	
DESIGNED BY	EST
DRAWN BY	TC
TRACED BY	
DESIGNED BY	
QUANTITIES BY	
CHECKED BY	
NO.	

DATE	REVISION
7/7/21	Rev. Dust fence height

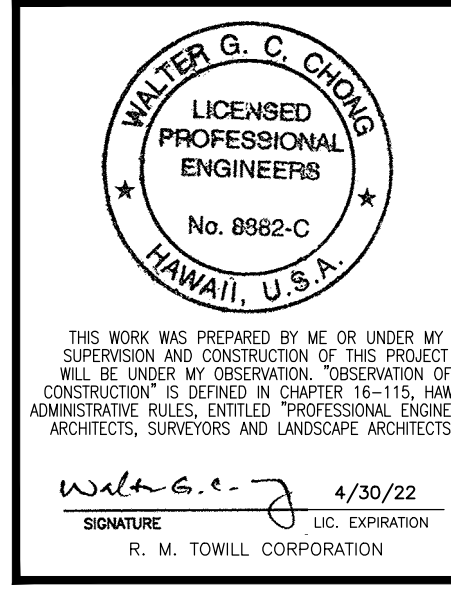

STATE OF HAWAII
DEPARTMENT OF TRANSPORTATION
HIGHWAYS DIVISION
DIVERSION ROAD-GRADING, EROSION AND SEDIMENT CONTROL PLAN
Kamehameha Highway
Kaipapau Stream Bridge Replacement
Federal Aid Project No. BR-083-1(48)
Scale: As Noted Date: February 2021

FED. ROAD DIST. NO.	STATE	PROJ. NO.	FISCAL YEAR	SHEET NO.	TOTAL SHEETS
HAWAII	HAW.	BR-083-1(48)	2021	35	161

Connect to exist. w16 D.I. pipe
Sta. 1246+52.0± Hwy.,
O/S 17.3± Rt.
=Sta. 0+00.0± 16" W.L.
=Sta. 0+00.0± Temp. W.L.
Materials for conn.
1-16" D.I. Sleeve, 15" long
8-LF 16" D.I.P., Cl. 53
1-16" 1/8 Bend, D.I. (H)
1-Conc. block
Temp. for testing
1-16" Cap w/4" C.O.
1-Conc. block

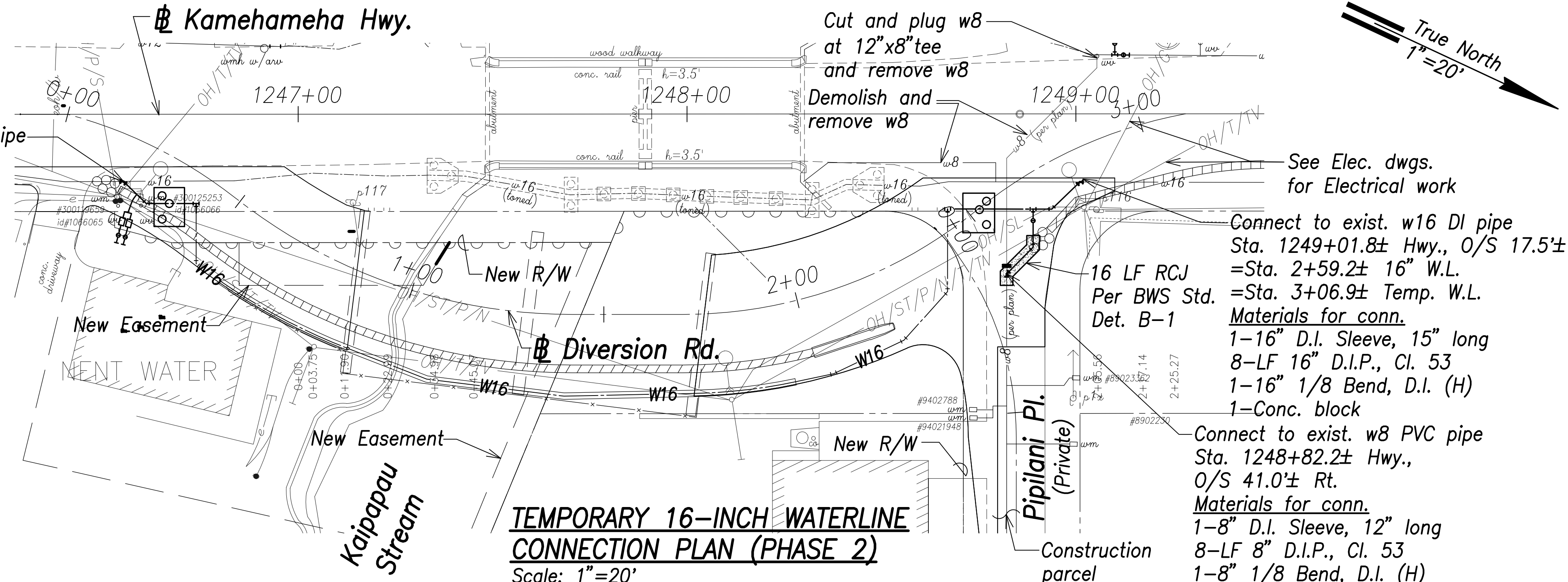

- Notes:**
- The existing waterlines shown on these plans were located using record drawings and toning information from the Board of Water Supply. The contractor shall make an independent check by probing the waterlines and coordinating with the Board of Water Supply to ascertain the exact locations of the waterlines. Any discrepancies shall be immediately brought to the attention of the Project Engineer prior to any work on the water system.
 - Connection of the temporary 16" waterline to the existing 16" waterline cannot begin until after the permanent 12" waterline has been pressure tested, accepted by BWS and placed into service and the temporary 12" waterline has been removed.

TEMPORARY 16-INCH WATERLINE CONNECTION PLAN (PHASE 2)
Scale: 1"=20'

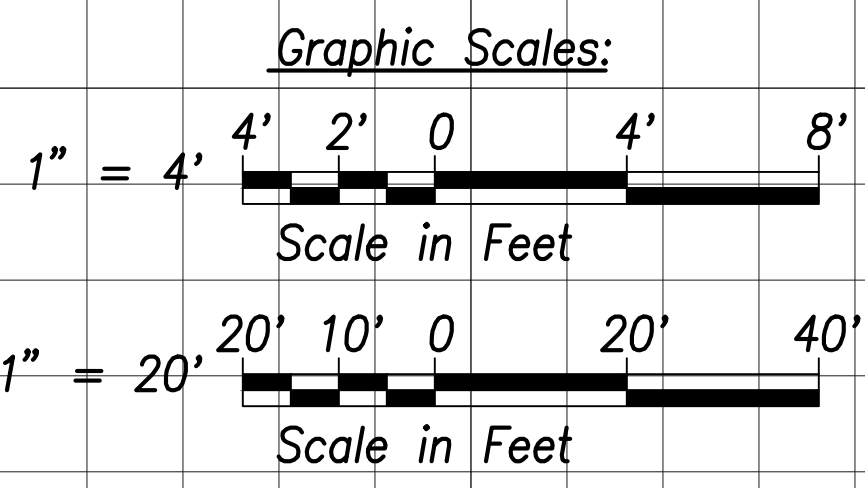
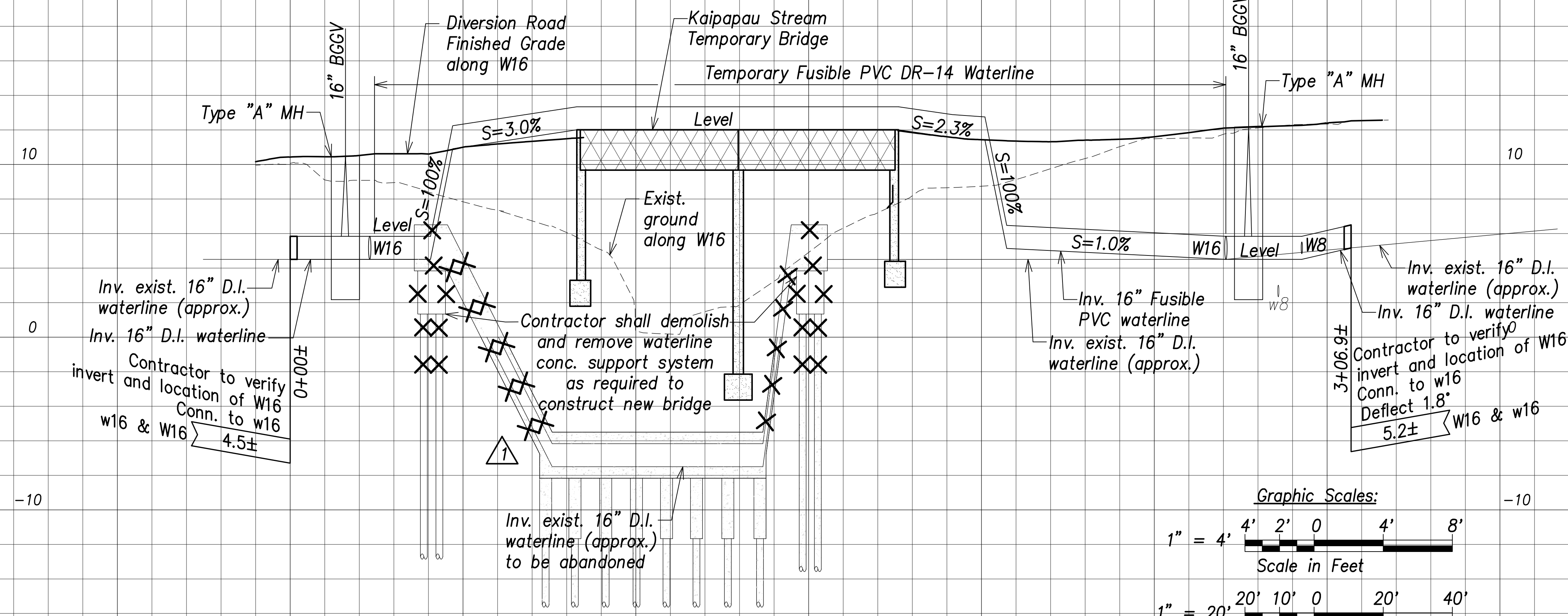

DATE	_____
DESIGNED BY	_____
DRAWN BY	_____
CHECKED BY	_____
NO.	_____

TEMPORARY 16-INCH WATERLINE CONNECTION PROFILE (PHASE 2)
Scales: 1"=20' Horiz.
1"=4' Vert.

APPROVED:
Manager and Chief Engineer, BWS
(for work affecting BWS facilities
State R/W & BWS easements only)

DATE: MAY 24 2021

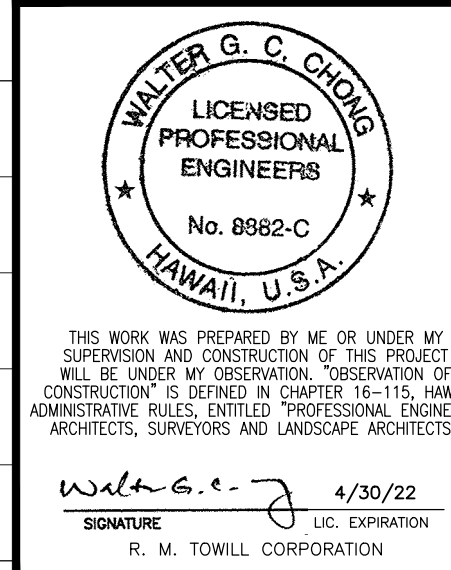

7/7/21	Rev. profile w16 removal limits
DATE	REVISION

STATE OF HAWAII
DEPARTMENT OF TRANSPORTATION
HIGHWAYS DIVISION

TEMPORARY 16-INCH WATERLINE CONNECTION PLAN (PHASE 2)
Kamehameha Highway
Kaipapau Stream Bridge Replacement
Federal Aid Project No. BR-083-1(48)

Scale: As Noted Date: February 2021

FED. ROAD DIST. NO.	STATE	PROJ. NO.	FISCAL YEAR	SHEET NO.	TOTAL SHEETS
HAWAII	HAW.	BR-083-1(48)	2021	37	161

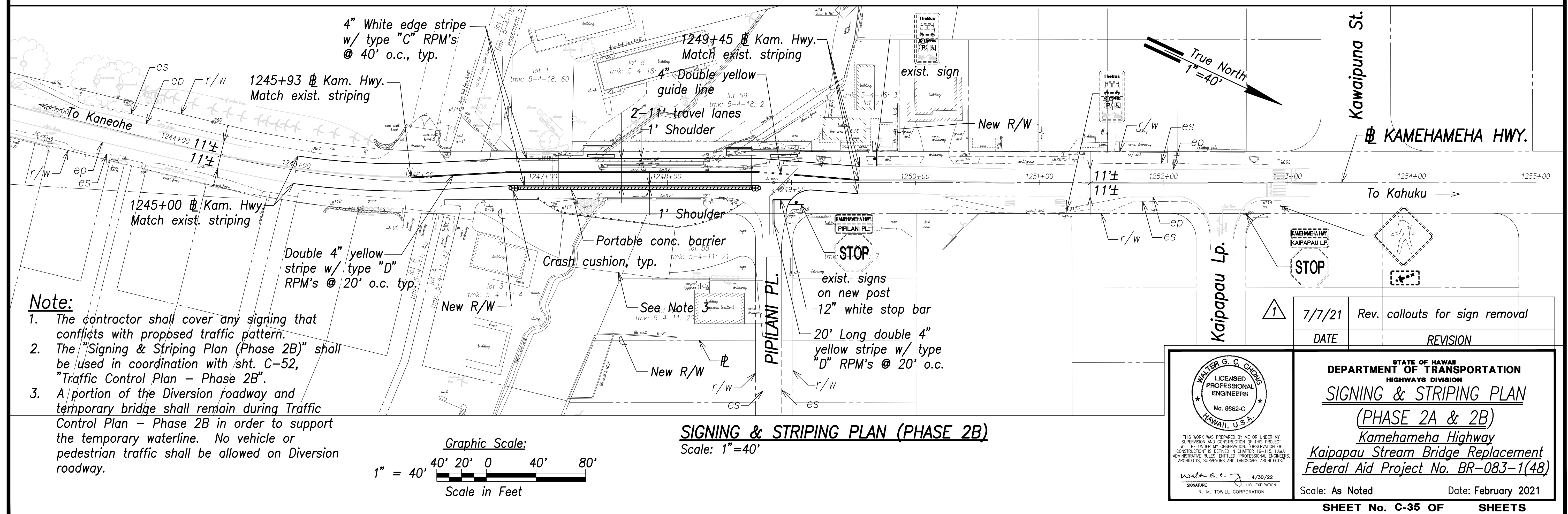
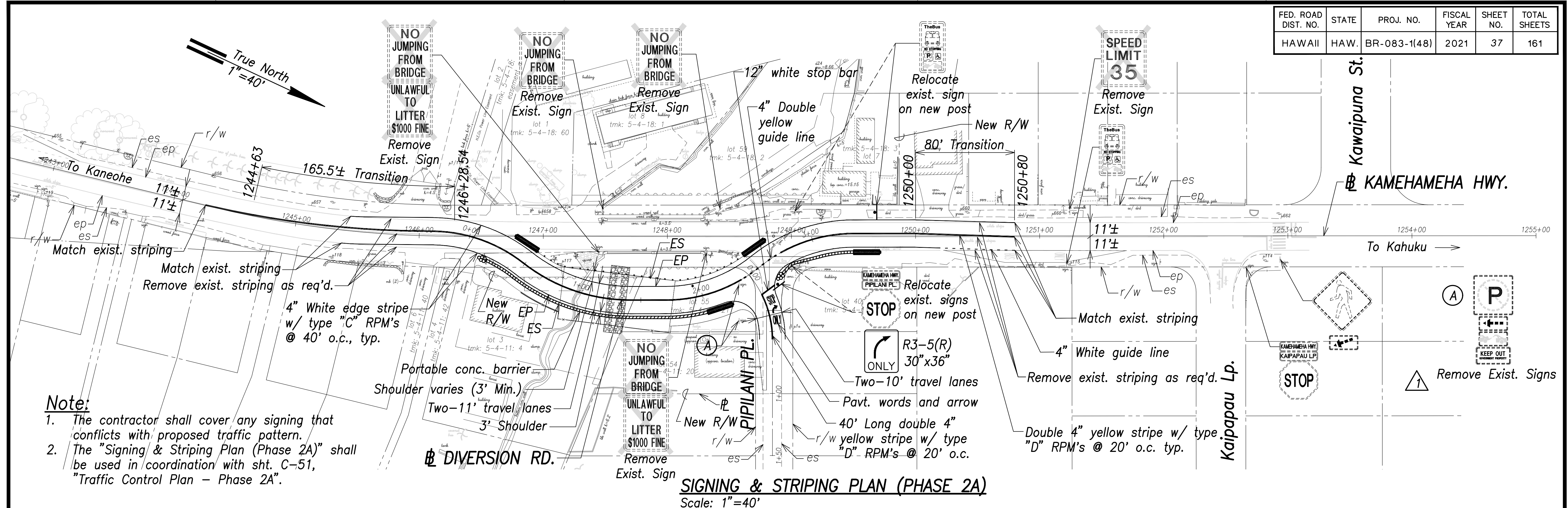

DATE	BY
DESIGNED BY	TC
TRACED BY	
DESIGNED BY	
QUANTITIES BY	
CHECKED BY	

WALTER G. C. CHONG
LICENSED PROFESSIONAL ENGINEERS
No. 8982-C
HAWAII, U.S.A.

Signature: *Walter G. C. Chong*
R. M. TOWILL CORPORATION
LIC. EXPIRATION: 4/30/22

STATE OF HAWAII
DEPARTMENT OF TRANSPORTATION
HIGHWAYS DIVISION
SIGNING & STRIPING PLAN
(PHASE 2A & 2B)
Kamehameha Highway
Kaipapau Stream Bridge Replacement
Federal Aid Project No. BR-083-1(48)

Scale: As Noted Date: February 2021

FED. ROAD DIST. NO.	STATE	PROJ. NO.	FISCAL YEAR	SHEET NO.	TOTAL SHEETS
HAWAII	HAW.	BR-083-1(48)	2021	39	161

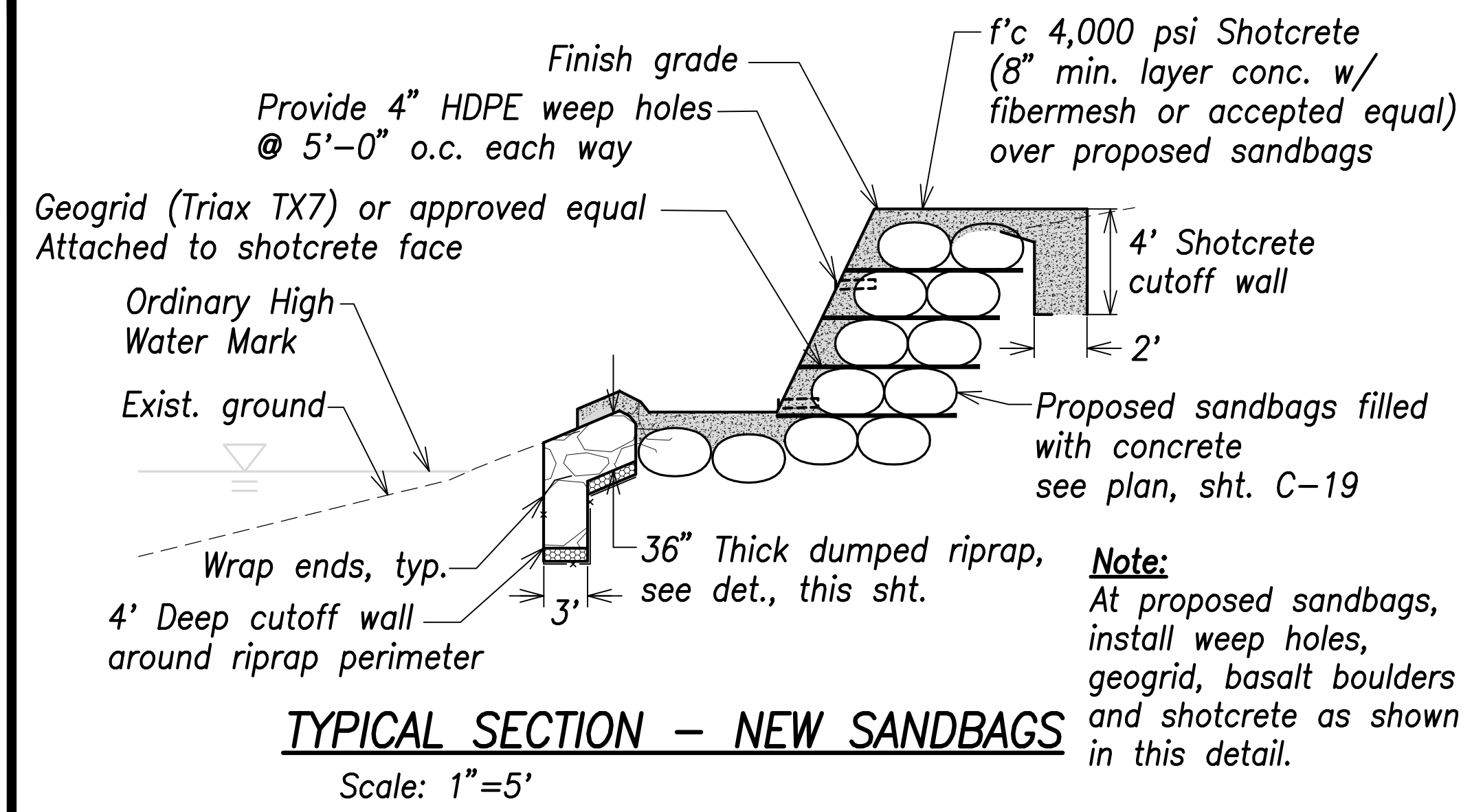

TYPICAL SECTION - NEW SANDBAGS
Scale: 1"=5'

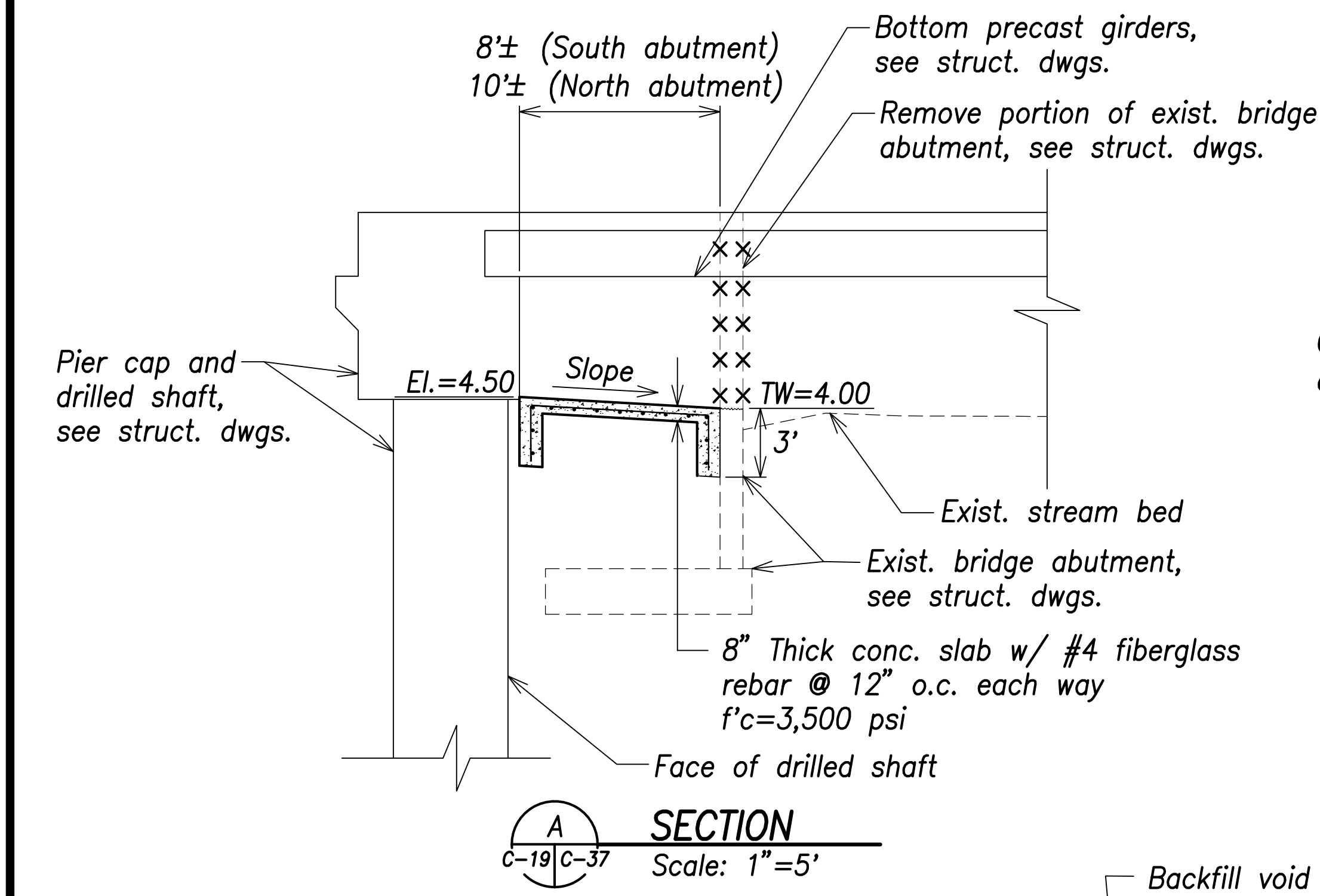

SECTION A
C-19/C-37 Scale: 1"=5'

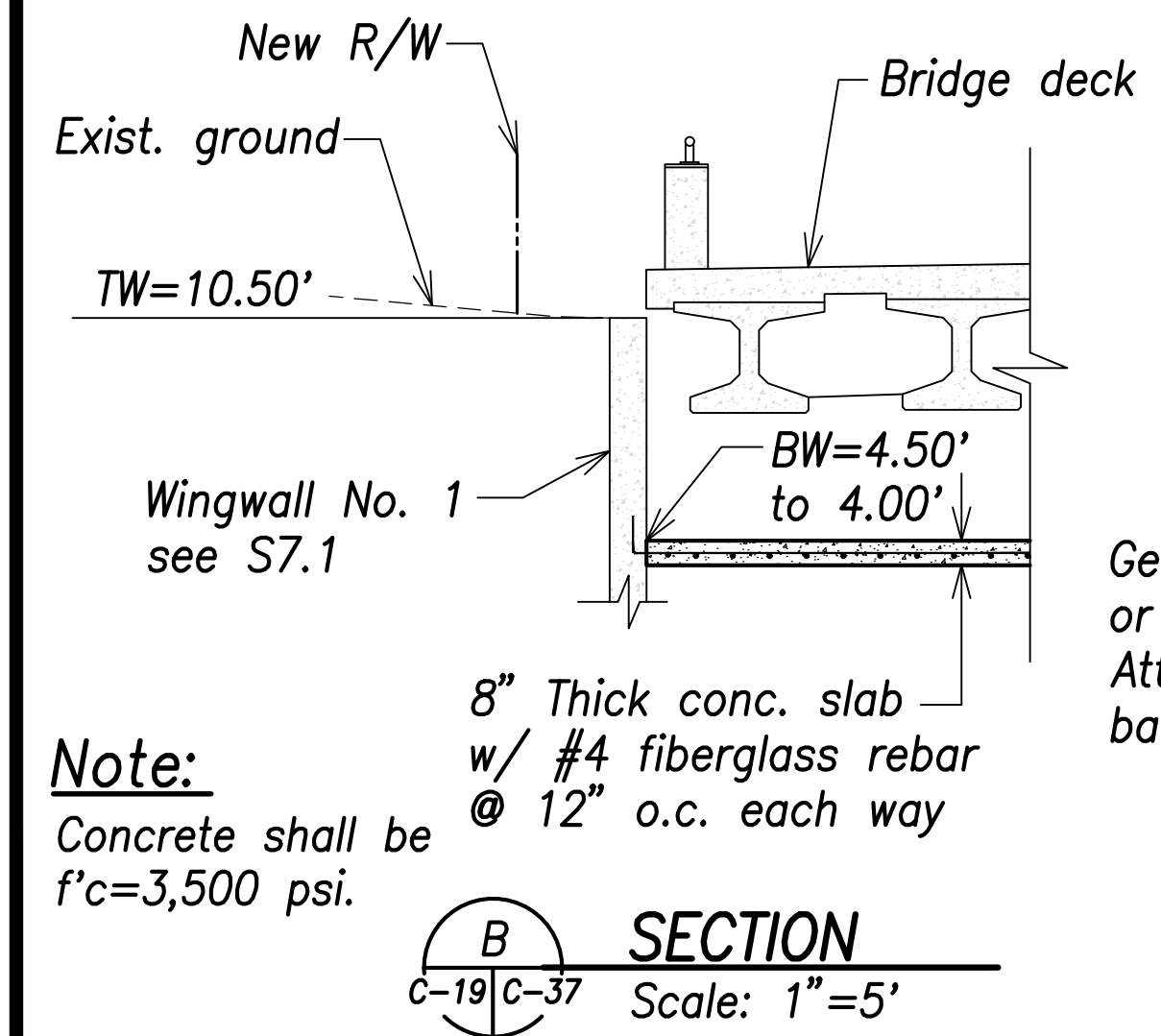

SECTION B
C-19/C-37 Scale: 1"=5'

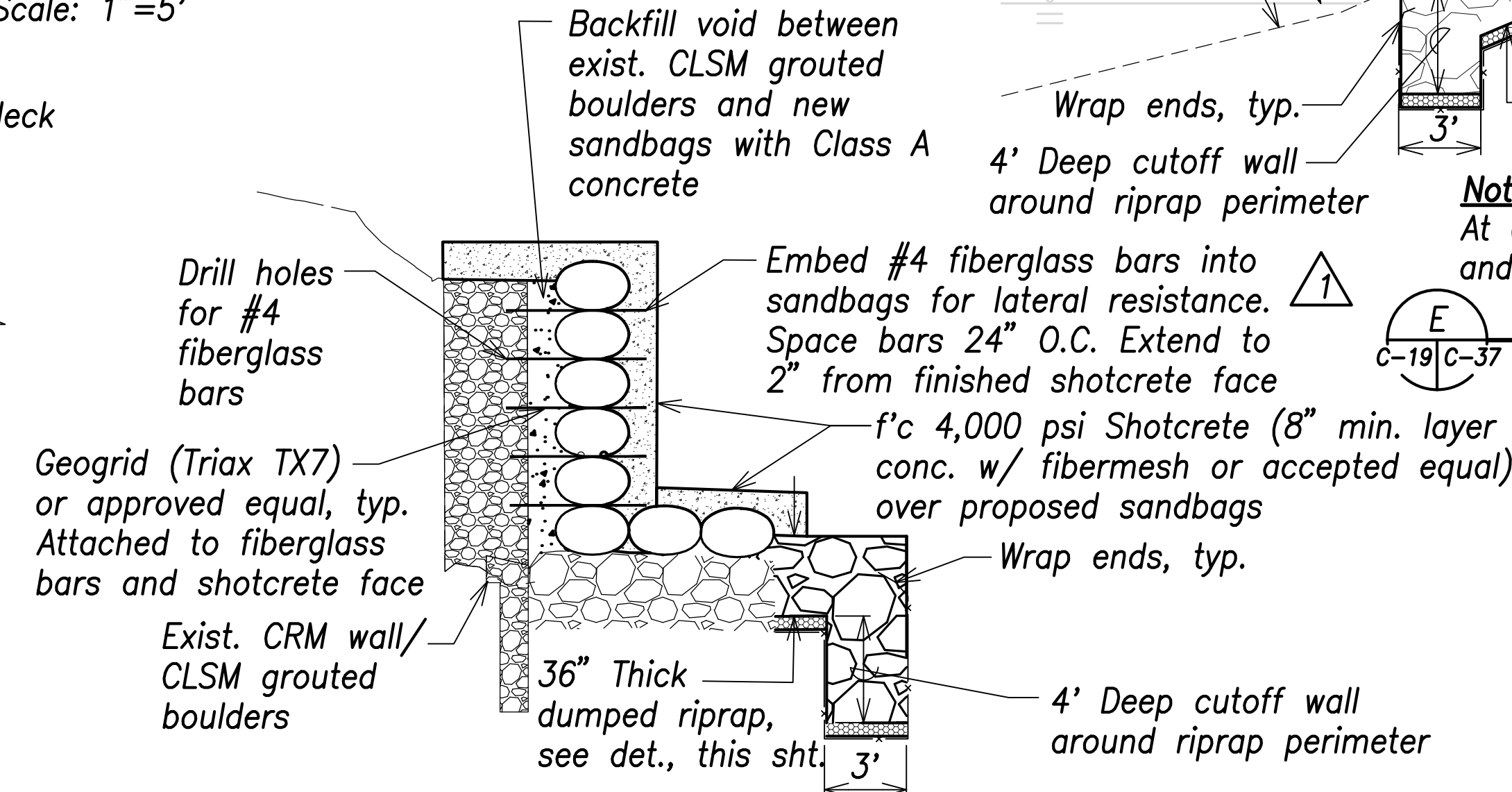

TYPICAL SECTION - NEW SANDBAGS AT CRM WALL
Scale: 1"=5'

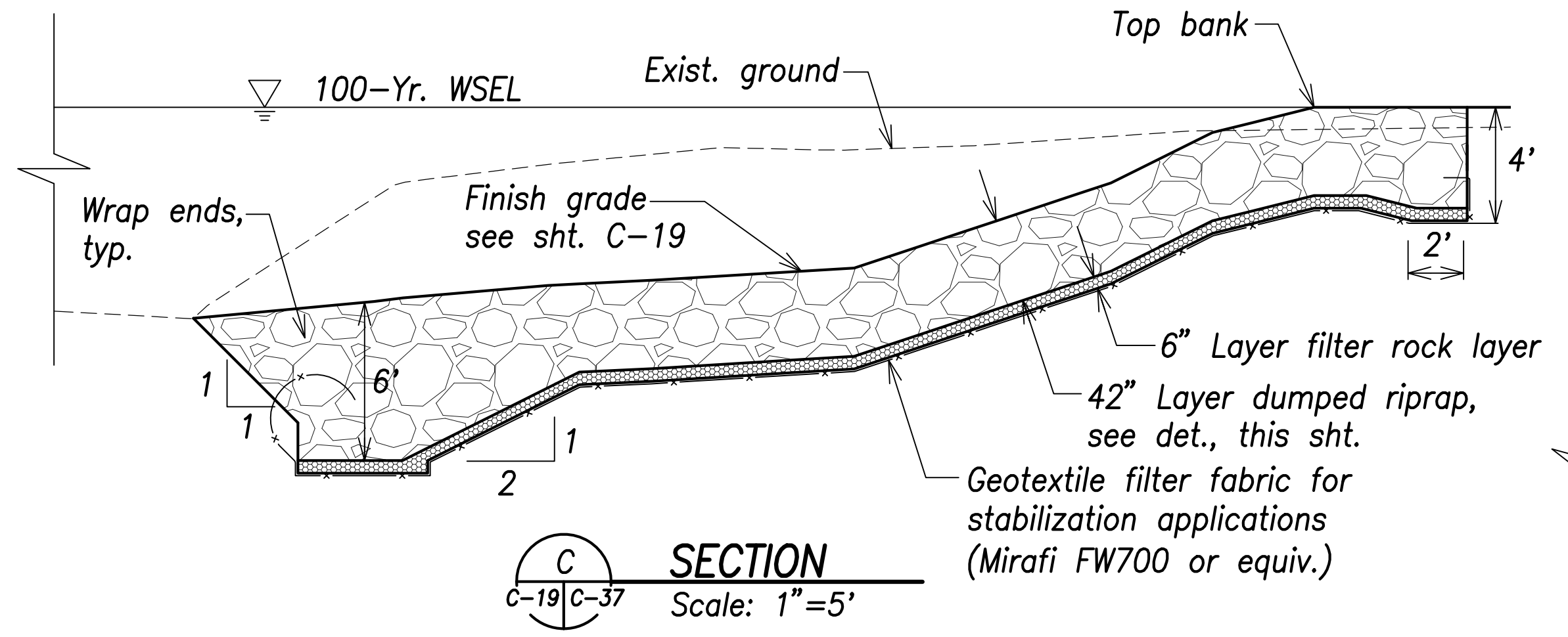

SECTION C
C-19/C-37 Scale: 1"=5'

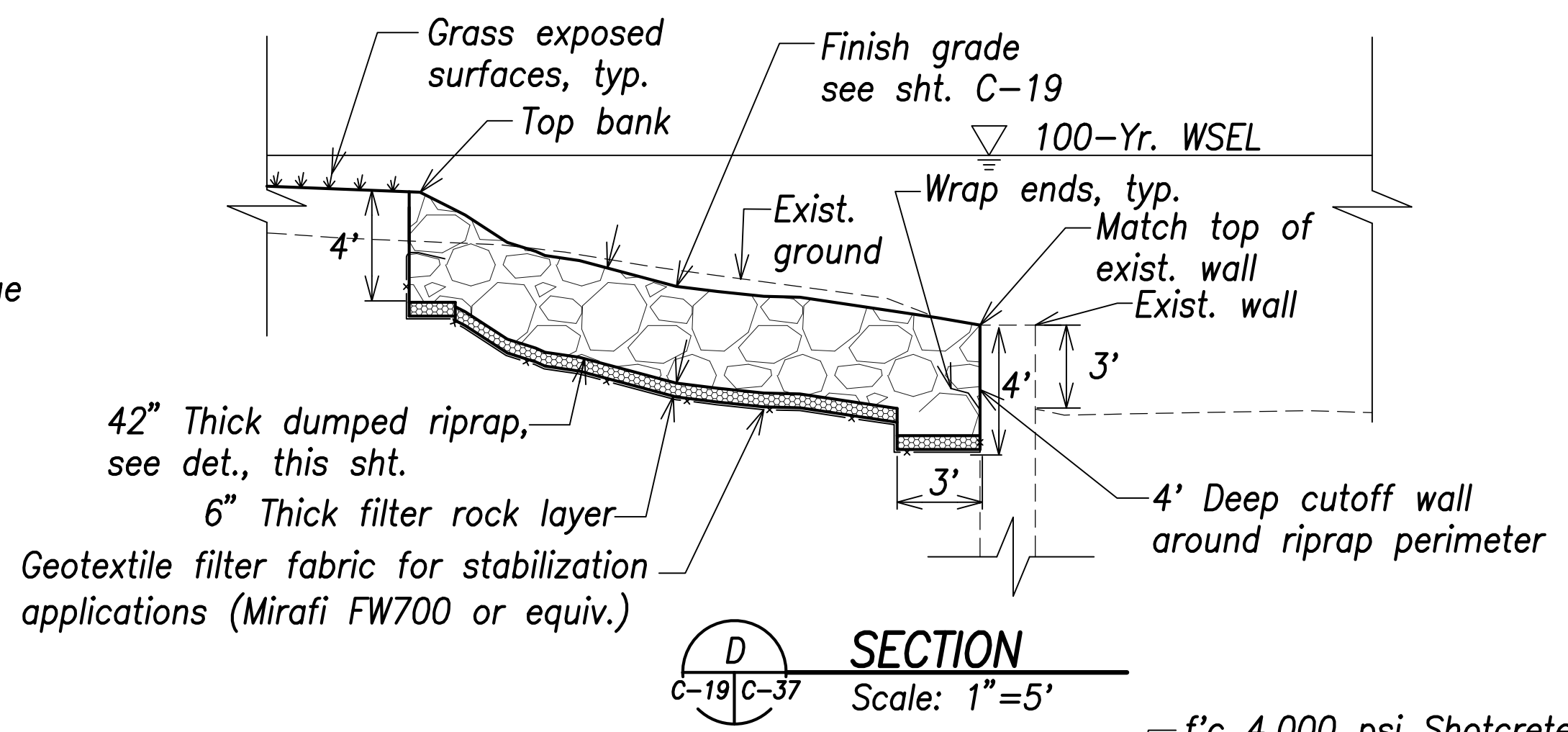

SECTION D
C-19/C-37 Scale: 1"=5'

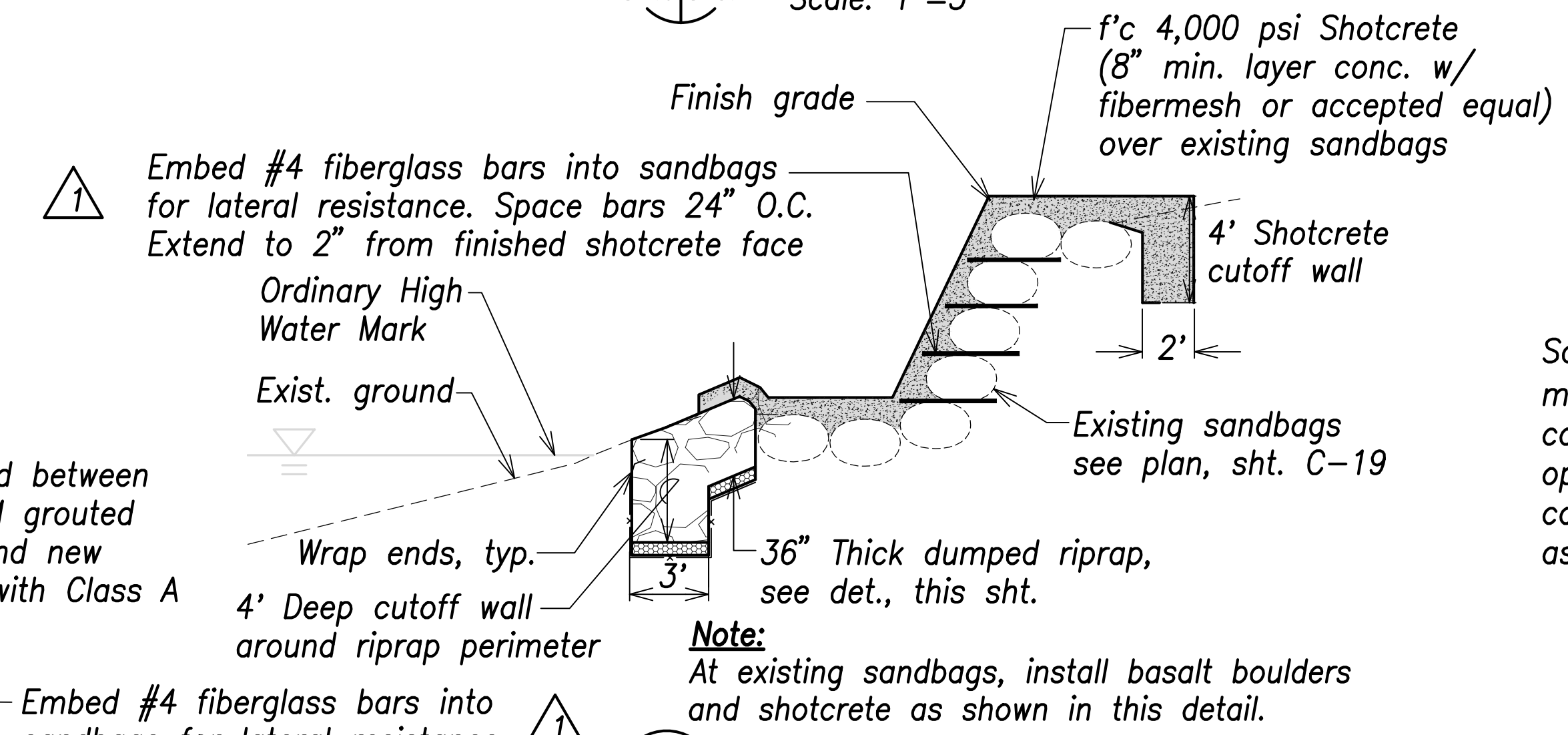

SECTION E
C-19/C-37 Scale: 1"=5'

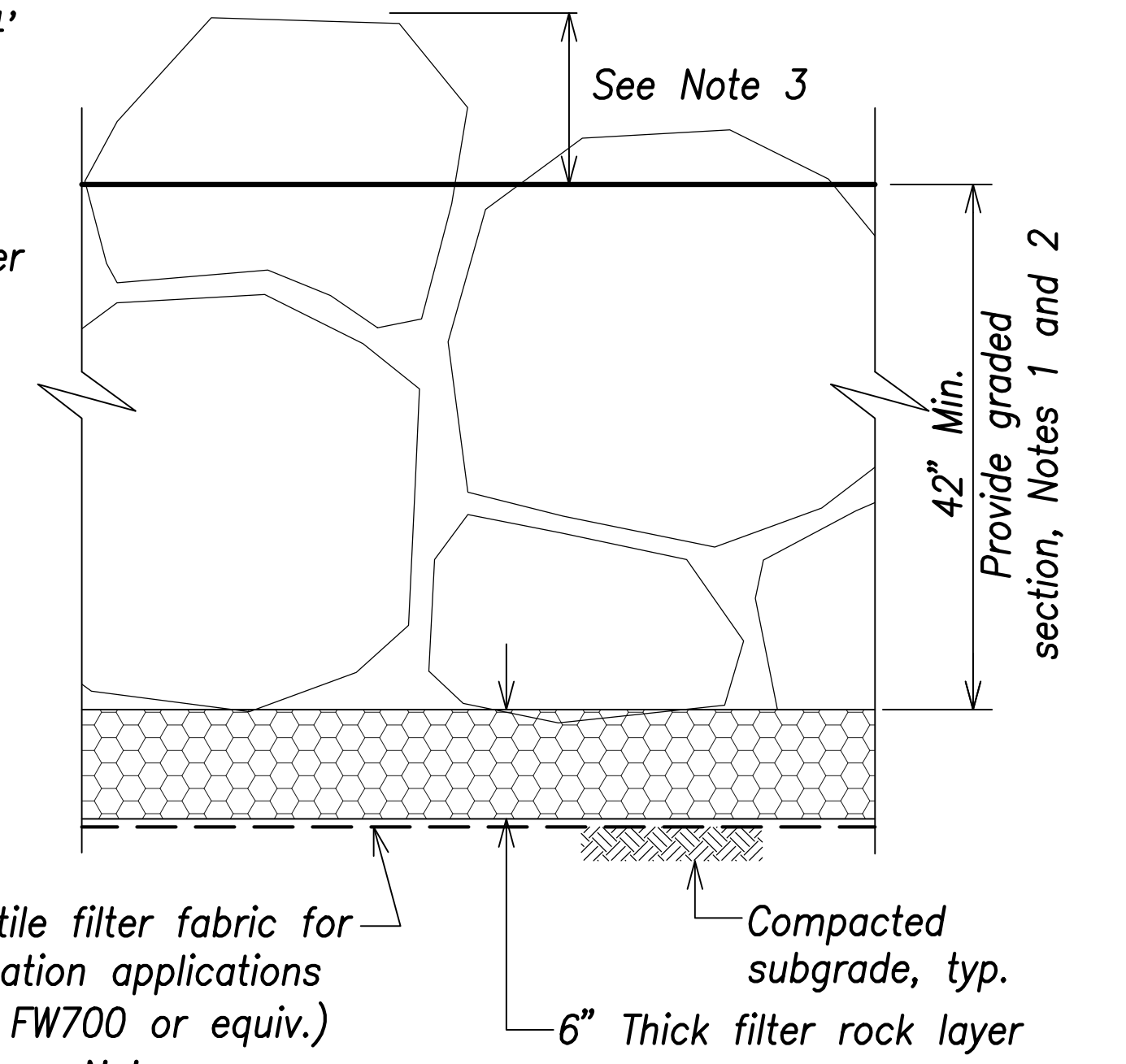

Geotextile filter fabric for stabilization applications (Mirafi FW700 or equiv.)

Notes:

- Riprap shall be basalt rock and consist of 27" average stone size.
- Riprap gradation:
 $D_{100} = 2.85'$ 2,000 lbs
 $D_{50} = 2.25'$ 1,000 lbs
 $D_{10} = 1.80'$ 500 lbs
- 12" Max. from highest adjacent rock finish top.

DUMPED RIPRAP
Not to Scale

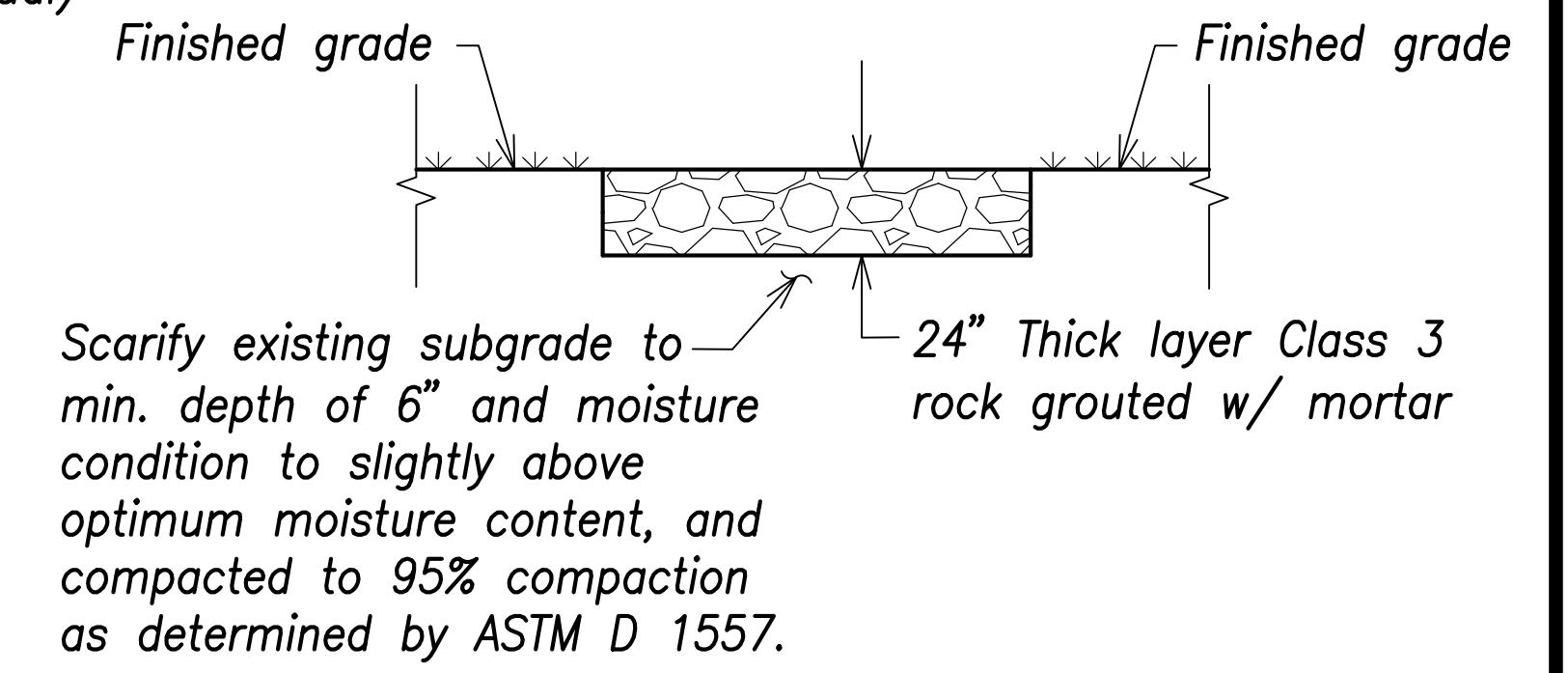

GROUTED RIPRAP SECTION
Not to Scale

DATE	REVISION
7/7/21	Add. 24" O.C. spacing for bars

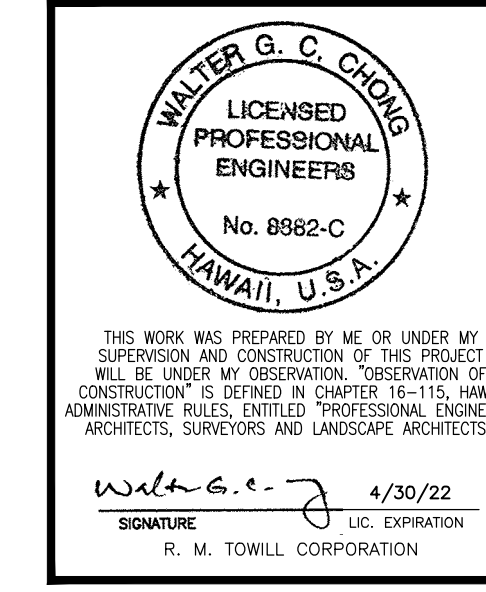

STATE OF HAWAII
DEPARTMENT OF TRANSPORTATION
HIGHWAYS DIVISION
STREAM BANK STABILIZATION & MISCELLANEOUS DETAILS
Kamehameha Highway
Kaipapau Stream Bridge Replacement
Federal Aid Project No. BR-083-1(48)

Scale: As Noted Date: February 2021

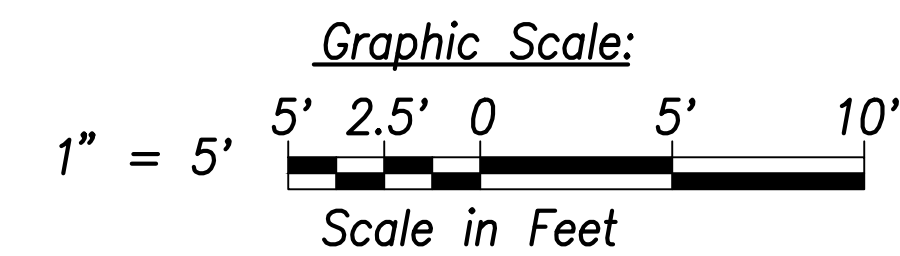

DATE	BY	REVISION

ORIGINAL PLAN
NOTE BOOK
QUANTITIES BY
CHECKED BY

**STATE OF HAWAII
DEPARTMENT OF TRANSPORTATION
HIGHWAYS DIVISION**

PRE-BID MEETING ATTENDANCE AND MINUTES FOR

Project Title: Kamehameha Highway, Kaipapau Stream Bridge Replacement

Federal-Aid Project No.: BR-083-1(48)

Date, Time & Place: June 22, 2021 at 1:30 p.m. HST
Pre-bid meeting was held virtually on Microsoft Teams.

Attendees:

Name	Organization/Company	Contact Information
Jennifer Russell	HDOT HWY-DD	jennifer.t.russell@hawaii.gov
Li Nah Okita	HDOT HWY-DD	li.nah.okita@hawaii.gov
Jillian Chen	HDOT HWY-DD	jillian.m.chen@hawaii.gov
Matthew Morita	HDOT HWY-OR	matthew.s.morita@hawaii.gov
Francis Perez	HDOT HWY-OR	francis.m.perez@hawaii.gov
Kevin Kasamoto	HDOT HWY-DH	kevin.kasamoto@hawaii.gov
Brent Wakuzawa	HDOT HWY-DB	brent.a.wakuzawa@hawaii.gov
Brandon Hee	HDOT HWY-LG	brandon.h.hee@hawaii.gov
Steven Yoshida	HDOT HWY-TD	steven.yoshida@hawaii.gov
Daniel Williams	HDOT OCR	Daniel.K.Williams@hawaii.gov
Karen Awana	HDOT OCR	karen.l.awana@hawaii.gov
Melanie Martin	HDOT OCR	Melanie.Martin@hawaii.gov
Walter Chong	R. M. Towill Corporation	WalterC@rmtowill.com
Emmanuel Minde	Global Specialty Contractors, Inc.	Eminde@globalspecialty.net
Sean McGowan	Kelikai Pacific Foundation	seanm@ssihawaii.com
Shane Lee	Hawaiian Dredging Construction Co.	spasion@hdcc.com

Items of Discussion:

- A. Jennifer Russell (HDOT HWY-DD) called the meeting to order at 1:30 p.m. and noted the following:
1. Anything said at the meeting was for clarification only. The bid documents shall govern over anything said in the meeting and discrepancies shall be clarified by addendum.
 2. Summarized the scope of work as described in the Notice to Bidders.
- B. Daniel Williams (HDOT OCR) discussed Sections IV, V.A., V.C. V.D. and XII of the Disadvantaged Business Enterprise (DBE) Requirements and noted the following:
1. The DBE Project Goal for this project is 4.8%.

2. Refer to Section VIII regarding Demonstration of Good Faith Efforts for Contract Award. Bidders are advised to document all discussions, phone calls, faxes, communications relating to their efforts in meeting the DBE goals with both non-DBE and DBE entities.
 3. All firms bidding or quoting on DOT projects including vendors, subcontractors, manufacturers, truckers, etc., must register as a bidder. The form can be downloaded from <https://hidot.hawaii.gov/administration/files/2019/03/Bidder-Registration-Fillable-Form.pdf>.
 4. Bidders are advised to check the DBE directory at <https://hdot.dbesystem.com> to ensure all the DBEs that they list on their DBE documents are indeed DBE-certified.
- C. Melanie Martin (HDOT OCR) emphasized that the DBE forms are due five (5) days after bid opening and explained how the five days are calculated. Refer to the footnote in Section V.C. of the DBE Requirements. Failure to provide the forms by the due date shall be cause for bid/proposal rejection.
- D. Bidders were invited to ask questions, but there were none.
- E. The following reminders were given:
1. All requests for information (RFIs) must be submitted in writing through HiePRO no less than 14 calendar days before bid opening. Bid opening is currently scheduled for Thursday, July 15, 2021 at 2:00 p.m., Hawaii Standard Time, so questions are due by Thursday, July 1, 2021 at 2:00 p.m. Any questions received after the deadline will not be addressed and verbal RFIs will not receive a response.
 2. All bidders must email their DBE Forms to the Project Manager within 5 calendar days after bid opening by Tuesday, July 20, 2021 at 2:00 p.m. Hawaii Standard Time. Failure to provide these documents shall be cause for bid/proposal rejection.
- F. The meeting concluded at 1:45 p.m.

**STATE OF HAWAII
DEPARTMENT OF TRANSPORTATION
HIGHWAYS DIVISION**

**Project: KAMEHAMEHA HIGHWAY
KAIPAPAU STREAM BRIDGE REPLACEMENT
FEDERAL AID PROJECT NO. BR-083-1(48)**

Prospective bidders had submitted RFIs in HlePRO. Questions and responses are as follows:

1. Can you provide us with a copy of the Geotech report?

Response: A copy of the report has been included in Addendum No. 1.

2. Please provide the geotechnical engineering report entitled "Geotechnical Engineering Exploration, Kamehameha Highway Replacement, Koolauloa, Oahu, Hawaii" dated August 6, 2014 by Geolabs, Inc. as stated on sheet G-2.

Response: See response to #1.

3. Sheet C-18 calls for 12'h Dust Fence while Sheet C-29 calls for 16'h Dust Fence. Please clarify.

Response: The dust fence along TMK: 5-4-11: 20 and within TMK: 5-4-11: 4 should be 16' high and the other dust fences should be 12' high. Sheets C-18 and C-29 have been revised to show this and have been included in Addendum No. 1.

4. Sheet C-17: Wingwalls No. 3 & No. 4: Please provide detail for the 6'h chain link fence & gate.

Response: The 6' high chain link fence & gate shall be constructed per HDOT Std. Plan D-02.

5. Sheet C-37: Please provide the on center spacing of the #4 fiberglass bars.

Response: The spacing shall be 24" on center. Sheet C-37 has been revised to show this and has been included in Addendum No. 1.

6. Sheet C-12, Typical Crash Cushion Section detail: Please provide dimension of the 8" Concrete Pad.

Response: The Energite III sand barrels can be placed on AC pavement. Sheet C-12 has been revised by deleting the callout of the concrete pad and the revised Sheet C-12 has been included in Addendum No. 1.

7. Please provide limit of removal for the 16" Waterline in the stream. Phase 2 on Sheet C-31 shows to remove 16"WL all the way down to the bend. Sheet C-33 shows to remove 16" waterline down to Elev +2.

Response: Sheet C-33 has been revised to show exist. 16" waterline to be removed down to the bend. The revised Sheet C-33 has been included in Addendum No. 1.

8. Sheet S2.2: Please confirm that the caissons are to be removed down to Elev. (-)7.30.

Response: The existing caissons shall be removed, at a minimum, down to Elev. (-)2.0. The portions of existing caissons that remain shall also be, at a minimum, 2'-0" below the finish grade and the bottom of the new structure.

9. Please provide as-built drawings for the existing Kaipapau Stream Bridge

Response: A copy of the available as-built drawings for the bridge from 1932 has been included in Addendum No. 1.

10. Please provide as-built drawings for the existing 16" Waterline.

Response: A copy of the available as-built drawings for the 16" waterline from 1992 has been included in Addendum No. 1.

11. How many W16 cradles are required? Sheet C-34 shows 17ea while Sheet S3.1 shows 2ea. Please clarify.

Response: The number of W16 cradles shall be based on the pipe requirements shown in the contract documents. Sheet C-34 provides criteria for the placement of the pipe supports (cradles). Sheet S1.1 (Layout Plan) notes that the balance of W16 cradles are not shown for clarity and to see sheet S11.1 and S11.1A for details. Sheet S11.1 notes that the Contractor shall submit locations of W16 cradles. The Contractor shall coordinate locations with the precast girder manufacturer, deck reinforcing, abutment reinforcing, and wing wall reinforcing.

12. We would like to request an extension to the bid date of 2 weeks.

Response: The bid opening date will not be extended at this time.

13. Sheet S8.1 Note 13. The Contractor shall record actual volume of drilled shaft concrete placed and compare with predicted and/or theoretical values. For bidding purposes, please provide a % for drilled shaft concrete over theoretical neat volume. This is also required for comparison per Note 13.

Response: The actual volume placed shall be compared to the theoretical volume and not the predicted volume.

14. Drilled shaft specification states "At the time of placement, the concrete temperature shall not exceed 85 degrees F". Due to the location of the project, there may be logistical challenges for concrete trucks arriving at the site within a specific time frame, 85 degrees may be a little rigid for the temperature requirement. We would like to request that the maximum temperature at time of placement be adjusted to "not exceed 90 degrees F". Slightly elevated temperature variations of 87 and 88 degrees have previously been accepted.

Response: Specification Section 511 has been revised to state "At the time of placement, the concrete temperature shall not exceed 90°F." The revised Specification Section 511 has been included in Addendum No 1.

15. Due to project complexities, please consider an extension of the bid date for this project.

Response: The bid opening date will not be extended at this time.

16. Due to prescriptive construction sequence as shown on plan sheets C11 and S0.7 and S0.8, Please consider a bid extension of 3 weeks in order to adequately quantify, coordinate with subcontractors & vendors, and price the required construction activities associated with the temporary bridge bypass and permanent bridge construction.

Response: The bid opening date will not be extended at this time.

17. Please provide copies of all utility agreements required or executed for construction of this project.

Response: Copies will not be provided.

18. Please provide copies of the 404 permit in order to determine allowable means and methods for all in water work including but not limited to construction of new temporary bridge pier, demolition of existing bridge foundations, and installation of permanent scour protection.

Response: The 404 permit documentation is provided in HlePRO as part of the documents for this project (see Nationwide Permit Pre-Construction Notification and Verification).

19. Please confirm that the installation of the temporary street light poles are the responsibility of 3rd party utility companies.

Response: Temporary street light luminaires and bracket arms will be mounted on temporary or permanent joint utility poles. All joint utility poles will be installed by the utility companies.

20. Please advise who is responsible for installation of pole P 117T.

Response: Temporary joint pole P117T will be installed by Hawaiian Electric.

21. Please advise if the existing US Signal Corps cable is to remain in service for the duration of the project. If the line is to remain in service, please provide a temporary utility plan for this service.

Response: The existing US Signal Corps cable is currently not-in-service and does not need to be temporarily relocated/reconnected during construction. Note that the cable will be cut and capped within the new Signal Corps manholes on the Kaneohe and Kahuku sides of the bridge.

22. Please confirm relocation of all utilities to be performed by 3rd parties shall be completed prior to construction NTP.

Response: Temporary relocation of electrical/telecommunications utilities will be performed after construction NTP.

23. Please confirm that all costs for 3rd party utility relocations as shown on the plans are the responsibility of HDOT.

Response: Cost for relocation of utility company overhead facilities (poles, conductors, transformers, etc.) will be the responsibility of the State and/or utility companies.

24. Please provided anticipated Notice to Proceed for this project.

Response: Notice to Proceed for this project is anticipated to be issued by September 25, 2021.

**FINAL SUBMISSION
GEOTECHNICAL ENGINEERING EXPLORATION
KAMEHAMEHA HIGHWAY (ROUTE 83)
KAIPAPAU STREAM BRIDGE REPLACEMENT
KOOLAULO, OAHU, HAWAII**

W.O. 5014-00(A) AUGUST 6, 2014

Prepared for

R.M. TOWILL CORPORATION

and

**STATE OF HAWAII
DEPARTMENT OF TRANSPORTATION
HIGHWAYS DIVISION**



THIS WORK WAS PREPARED BY
ME OR UNDER MY SUPERVISION.

SIGNATURE 4-30-16
EXPIRATION DATE
OF THE LICENSE



GEOLABS, INC.
Geotechnical Engineering and Drilling Services
2006 Kalihi Street • Honolulu, HI 96819

Hawaii • California



GEOLABS, INC.

Geotechnical Engineering and Drilling Services

August 6, 2014
W.O. 5014-00(A)

Mr. Walter Chong
R.M. Towill Corporation
2024 North King Street, Suite 200
Honolulu, HI 96819

Dear **Mr. Chong**:

Geolabs, Inc. is pleased to submit our report entitled "Geotechnical Engineering Exploration, Kamehameha Highway (Route 83), Kaipapau Stream Bridge Replacement, Koolauloa, Oahu, Hawaii" prepared for the design of the replacement bridge project.

Our work was performed in general accordance with the scope of services outlined in our fee proposal dated September 20, 2001.

Please note that the soil and/or rock core samples recovered during our field exploration (remaining after testing) will be stored for a period of two months from the date of this report. The samples will be discarded after that date unless arrangements are made for a longer sample storage period. Please contact our office for alternative sample storage requirements, if appropriate.

Detailed discussion and specific design recommendations are contained in the body of this report. If there is any point that is not clear, please contact our office.

Very truly yours,

GEOLABS, INC.

Clayton S. Mimura, P.E.
President

CSM:RML:GS:mj

**FINAL SUBMISSION
 GEOTECHNICAL ENGINEERING EXPLORATION
 KAMEHAMEHA HIGHWAY (ROUTE 83)
 KAIPAPAU STREAM BRIDGE REPLACEMENT
 KOOLAULOA, OAHU, HAWAII**

W.O. 5014-00(A) AUGUST 6, 2014

TABLE OF CONTENTS

	Page
SUMMARY OF FINDINGS AND RECOMMENDATIONS.....	iii
1. GENERAL.....	1
1.1 Introduction.....	1
1.2 Project Considerations.....	1
1.3 Purpose and Scope.....	2
2. SITE CHARACTERIZATION.....	4
2.1 Regional Geology.....	4
2.2 Site Description.....	5
2.3 Subsurface Conditions.....	5
2.4 Earthquakes and Seismicity.....	7
2.5 Field Percolation Tests.....	8
3. DISCUSSION AND RECOMMENDATIONS.....	9
3.1 General Information.....	9
3.2 Seismic Design Considerations.....	10
3.3 Stream/Channel Material for Scour Analysis.....	11
3.4 Drilled Shaft Foundations.....	12
3.4.1 Uplift Load Resistance.....	13
3.4.2 Lateral Load Resistance.....	14
3.4.3 Foundation Settlements.....	15
3.4.4 Construction Considerations.....	15
3.4.5 Workmanship.....	16
3.4.6 Trial Shaft Program.....	17
3.4.7 Non-Destructive Integrity Testing.....	19
3.5 Structure Approach Slabs.....	20
3.6 Retaining Structures.....	21
3.6.1 Static Lateral Earth Pressures.....	21
3.6.2 Dynamic Lateral Earth Forces.....	22
3.6.3 Drainage.....	23
3.7 Bypass Roadway.....	24
3.8 Temporary Segmental Retaining Wall.....	24
3.9 Site Grading.....	26
3.10 Underground Water Line.....	27
3.11 Design Review.....	28
3.12 Post Design / Construction Observation Services.....	29

4. LIMITATIONS..... 30

CLOSURE..... 32

PLATES

- Project Location Map..... Plate 1
- Site Plan Plate 2
- Generalized Geologic Cross-Section A-A' Plate 3
- Drilled Shaft Load Test Detail Plate 4
- Access Tube Detail for Crosshole Sonic Logging Test Plate 5

APPENDIX A

- Field Exploration..... Page A-1
- Soil Log Legend Plate A
- Logs of Borings..... Plates A-1 thru A-7

APPENDIX B

- Laboratory Tests Page B-1
- Laboratory Test Data Plates B-1 thru B-8

APPENDIX C

- Field Percolation Tests Page C-1
- Percolation Test Data Plates C-1 thru C-8

APPENDIX D

- Core Photographs Plates D-1 thru D-7

FINAL SUBMISSION
GEOTECHNICAL ENGINEERING EXPLORATION
KAMEHAMEHA HIGHWAY (ROUTE 83)
KAIPAPAU STREAM BRIDGE REPLACEMENT
KOOLAULOA, OAHU, HAWAII
W.O. 5014-00(A) AUGUST 6, 2014

SUMMARY OF FINDINGS AND RECOMMENDATIONS

Our exploratory program generally involved drilling three deep borings at the future abutment and center pier locations for the Kaipapau Stream Bridge Replacement project. In addition, we also drilled four shallow borings along the roadway for utility relocations, earthwork and pavement design purposes. Generally, we encountered stiff surface fill materials placed over loose to very loose recent alluvium followed by dense old alluvium. Conglomerate and saprolitic soils were encountered below the old alluvium, and basalt formation was encountered below the saprolitic soil horizon in some of the deeper borings. Groundwater was encountered at depths ranging from about 5.9 to 10 feet below the existing ground surface. We did not encounter groundwater in Boring Nos. 6 and 7.

Based on the subsurface conditions encountered, the estimated scour depth, and the foundation loads provided, we recommend utilizing a deep foundation system consisting of drilled shafts to support the replacement bridge structure. In general, we recommend utilizing a nominal shaft diameter of 4 feet embedded into the dense old alluvium, conglomerate and/or basalt formation to support the abutments. The recommended minimum drilled shaft lengths range from 70 to 84 feet for the south abutment and 52 to 68 feet for the north abutment.

It should be noted that potentially difficult drilling conditions may be encountered during installation of the drilled shafts due to the presence of very loose alluvial soils, hard basaltic boulders and cobbles, and shallow groundwater levels. Therefore, placement of concrete by tremie methods will be required for the drilled shafts where groundwater would be encountered within the depths of the drilled shafts.

The text of this report should be referred to for more detailed discussions and specific design recommendations.

END OF SUMMARY OF FINDINGS AND RECOMMENDATIONS

SECTION 1. GENERAL

1.1 Introduction

This report presents the results of our geotechnical engineering exploration performed for the Kaipapau Stream Bridge Replacement project located along Kamehameha Highway (Route 83) at Mile Post (MP) 20.99 in the Koolauloa area on the Island of Oahu, Hawaii. The project location and general vicinity are shown on the Project Location Map, Plate 1.

This report summarizes our findings and presents our geotechnical engineering recommendations derived from our field exploration, laboratory testing, and engineering analyses. These recommendations are intended for the design of foundations, retaining structures, and site grading only. The findings and recommendations presented herein are subject to the limitations noted at the end of this report.

1.2 Project Considerations

The replacement bridge project site is along Kamehameha Highway traversing Kaipapau Stream and is adjacent to some residential dwellings. We understand it is proposed to demolish the existing bridge structure and construct a replacement bridge across Kaipapau Stream. The existing bridge structure is a two-span bridge with a total span of about 82 feet measured from abutment to abutment. The existing bridge structure is supported on a composite foundation system consisting of timber piles and shallow spread footings.

We understand the existing bridge is hydraulically inadequate and does not conform to current State of Hawaii - Department of Transportation (HDOT) and Federal Highway Administration (FHWA) design standards. Due to site constraints and hydraulic requirements, the bridge structure should not significantly increase the elevation of the approaches to the bridge and the bridge deck elevation.

The current design concept involves replacing the existing bridge with a new concrete bridge that will meet current HDOT and FHWA standards. Based on the available plans, the new bridge structure will be a concrete girder bridge measuring 110 feet long by 57 feet wide supported by abutments at both ends. A temporary

bypass roadway will be constructed on the makai side of the bridge to allow traffic to traverse around the bridge construction area.

In general, the existing abutments will be kept in place with the new abutments positioned behind the existing abutment structures. In addition, the existing center pier structure will be demolished. The planned finished deck elevation of the new bridge structure will be about +11.5 to +13.0 feet Mean Sea Level (MSL). The bottom of footing elevation for the abutments is set at approximately +2.40 and +3.52 feet MSL for Abutment Nos. 1 and 2, respectively. In addition, new wing walls will be constructed at the abutment structures. It should be noted that a pavement justification report presenting the pavement structural sections will be provided separately.

1.3 Purpose and Scope

The purpose of our geotechnical engineering exploration is to obtain an overview of the surface and subsurface conditions to develop a soil and/or rock data set to formulate geotechnical recommendations for design of the bridge replacement project. Our work was performed in general accordance with our fee proposal dated September 20, 2001. Our scope of work generally consisted of the following tasks and work efforts:

1. Review of available in-house soil and geologic information around the bridge replacement project location.
2. Application of the necessary excavation permits from the City and County of Honolulu and State of Hawaii – Department of Transportation, Highways Division prior to drill crew mobilization (including preparation of a traffic control plan).
3. Coordination of the utility toning with the various utility companies and utility clearance of the proposed boring locations by our field engineer/geologist.
4. Provision of traffic control at the proposed boring locations during our field exploration program.
5. Mobilization and demobilization of truck-mounted drilling equipment, water truck, and operators to the project site and back.

6. Drilling and sampling of seven borings extending to depths ranging from about 13 to 112.5 feet below the existing ground for a total of about 397.5 lineal feet of exploration.
7. Coordination of the field exploration and logging of the borings by our field geologist.
8. Performance of eight percolation tests to evaluate the permeability characteristics of the subsurface materials for dewatering considerations.
9. Laboratory testing of selected soil and/or rock core samples obtained during the field exploration as an aid in classifying the materials encountered and evaluating their engineering properties.
10. Analyses of the field and laboratory data to develop geotechnical recommendations for design of the bridge replacement project.
11. Preparation of this report summarizing our work on the project and presenting our findings and geotechnical design recommendations. In addition, a separate pavement justification report was prepared for the bridge approach pavements.
12. Coordination of our work on the project by our engineer.
13. Quality assurance of our overall work on the project and client/design team consultation by our principal engineer.
14. Miscellaneous work efforts such as drafting, word processing, clerical support, and reproductions.

Detailed descriptions of our field exploration methodology and the Logs of Borings are presented in Appendix A. Results of the laboratory tests performed on selected soil samples obtained from our field exploration are presented in Appendix B. Results of the field percolation tests performed are presented in Appendix C. Core photographs are presented in Appendix D.

END OF GENERAL

SECTION 2. SITE CHARACTERIZATION

2.1 Regional Geology

The Island of Oahu was formed by the merging of basalt lavas erupted from the prominent Wai`anae and Ko`olau Volcanoes. Of the two, the Wai`anae Volcano is the older volcano that breached the ocean surface nearly 4 million years ago. The Ko`olau Volcano rose above sea level approximately 2.7 million years ago, making it the younger of the two volcanoes.

In general, the two volcanoes were built by the long-term eruption of thinly bedded a`a and pahoehoe type lava flows, which erupted from the elongated and linear trending volcanic vents associated with the prominent rift zones of each of the volcanoes. The Ko`olau lavas banked against the lava flows of the Wai`anae Volcano to form the Schofield Plateau of the central interior portion of Oahu. The Wai`anae Mountains, which form the western third of the Island of Oahu, contain the oldest basalt rock formations on the Island. The Ko`olau Mountains form the eastern two-thirds of the island and include the rock layers exposed along the Ko`olau Pali extending from Waimanalo to Kahuku.

During the final stages of eruption and continuing well after the cessation of Wai`anae and Ko`olau volcanic eruptions, the island mass began to subside thousands of feet under the tremendous weight of the rock. In addition to the subsidence of the island, the force of stream erosion worked in conjunction with the large-scale fracture and slumping of portions of the land mass to form the island's topography of today. Erosion by streams and ocean waves has continued to work on the exposed land surfaces to form the topography of the present day.

The coastal area of Koolauloa lies within the Coastal Plain of Oahu and is to the northeast of the Ko`olau Mountain. As a result, much of the generally flat land area is underlain by unconsolidated coastal sediments (coralline sands and silts) with pockets of hard, cemented sand dunes (sandstone) and coral/limestone rock formation. Progressing toward the hills of the Ko`olau Mountains, the subsurface conditions gradually change to reflect an increase in thickness of terrestrial sediments, such as the

alluvial soils derived from the hills and valleys located to the southwest of the coastline. The alluvial soils may overlie the buried coral and sand deposits in the subsurface.

The coral and limestone rock encountered in the subsurface often contain locally occurring voids and cavity structures originating during the deposition of the calcareous deposits in shallow marine environments. In addition, some of the voids develop following the coral and limestone deposition as a result of the slow percolation of freshwater down through the geologic strata leaching the calcareous mineralogy of the materials.

2.2 Site Description

The project site is at Kamehameha Highway (Route 83), MP 20.99, in the Koolauloa area on the Island of Oahu, Hawaii. The existing bridge, which spans across Kaipapau Stream, is a two-lane, two-span concrete structure supported by two abutments and one center pier. The north abutment is supported by timber piles while the center pier and the south abutment are supported on shallow continuous strip footings. The existing bridge is approximately 82 feet long by 28 feet wide. A wooden pedestrian walkway was observed along upstream side of the existing bridge. The bridge center pier, abutments and wing walls are constructed of cement rubble masonry (CRM) and concrete construction.

Based on the topographic survey, the existing bridge deck elevations range from about +11 to +12 feet MSL. Residential properties with existing dwellings about the bridge site.

2.3 Subsurface Conditions

Our field exploration program consisted of drilling and sampling seven borings, designated as Boring Nos. 1 through 7, extending to depths from about 13 to 112.5 feet below the existing ground surface at the proposed bridge alignment. Generally, Boring Nos. 1 through 3 were drilled at the proposed south abutment, center pier and north abutment locations, respectively. Boring Nos. 4 and 5 were drilled at the south side of the bridge approach, and Boring Nos. 6 and 7 were drilled at the north side of the bridge approach. The approximate boring locations are shown on the Site Plan, Plate 2.

In general, we encountered surface fills consisting of medium stiff to stiff clays and silts extending to about 8 feet below the existing ground. The fills were underlain by recent alluvium consisting of loose to very loose sands and gravel. The recent alluvium grades to older alluvium at about 28 to 31 feet below the existing roadway level. The older alluvium consists of sandy gravel and grades with cobbles and boulders at greater depths. Conglomerate and saprolitic soils (varying from dense/stiff to hard) were encountered below the older alluvium. Basalt formation was encountered below the saprolitic soil horizon at various depths below the ground level. The basalt formation (or saprolitic soils) extended to the maximum depth explored of about 112.5 feet below the existing ground surface. It should be noted that the saprolitic soil and/or basalt formation layer was not encountered at Boring No. 3 (within the stream channel) at the maximum depth explored of about 112 feet below the roadway level.

An idealized cross section depicting the anticipated subsurface conditions at the new bridge site is shown on the Generalized Geologic Cross-Section, Plate 3. The approximate surface projections of the idealized cross section prepared for this report is shown on the Site Plan, Plate 2.

We encountered groundwater in the borings at depths of about 5.9 to 10 feet below the existing ground surface at the time of our field exploration. These groundwater depths correspond to elevations ranging from about +1.5 to +3.1 feet MSL. It should be noted that groundwater levels are expected to fluctuate depending on tides, seasonal rainfall, time of year, surface runoff, and other factors. Considering the bridge is adjacent to an active stream, the groundwater level at the site will vary in response to the water level in the stream.

Detailed descriptions of the field exploration methodology are presented in Appendix A. Descriptions and graphic representations of the materials encountered in the borings are provided on the Logs of Borings, Plates A-1 through A-7. Results of the laboratory tests performed on selected soil samples retrieved from our field exploration are presented in Appendix B. The field percolation test results are presented in Appendix C.

2.4 Earthquakes and Seismicity

In general, earthquakes that occur throughout the world are caused by shifts in the tectonic plates. In contrast, earthquake activity in Hawaii is primarily linked to volcanic activity. Therefore, earthquake activity in Hawaii generally occurs before or during volcanic eruptions. In addition, earthquakes may result from the underground movement of magma that comes close to the surface but does not erupt. The Island of Hawaii experiences thousands of earthquakes each year, but most are so small that they can only be detected by sensitive instruments. However, some of the earthquakes are strong enough to be felt, and a few cause minor to moderate damage.

In general, earthquakes associated with volcanic activity are most common on the Island of Hawaii. Earthquakes that are directly associated with the movement of magma are concentrated beneath the active Kilauea and Mauna Loa Volcanoes on the Island of Hawaii. Because the majority of the earthquakes in Hawaii (over 90 percent) are related to volcanic activity, the risk of seismic activity and degree of ground shaking diminishes with increased distance from the Island of Hawaii. The Island of Hawaii has experienced numerous earthquakes greater than Magnitude 5 (M5+); however, earthquakes are not confined only to the Island of Hawaii.

To a lesser degree, the Island of Maui has experienced numerous earthquakes greater than Magnitude 5. Therefore, moderate to strong earthquakes have occurred in the County of Maui. The effects of earthquakes occurring on the Islands of Hawaii and Maui may be felt on the Island of Oahu. For example, several small landslides occurred on the Island of Oahu as a result of the Maui Earthquake of 1938 (M6.8). In addition, some houses on the Island of Oahu were reportedly damaged as a result of the Lanai Earthquake of 1871 (M7+).

Over the last 150 years of recorded history, we are not aware of reported earthquakes greater than Magnitude 6 occurring on the Island of Oahu. We understand that an earthquake of Magnitude 4.8 to 5.0 occurred along the Diamond Head Fault in 1948 on the Island of Oahu. The moderate tremor resulted in broken store windows, ruptured building walls, and broken underground water mains.

2.5 Field Percolation Tests

Eight field permeability tests were conducted at the proposed replacement bridge abutment locations to evaluate the infiltration characteristics of the subsurface materials encountered in the borings. The permeability tests were performed in Boring Nos. 1 and 3.

Four falling head and four constant head permeability tests were performed to evaluate the average hydraulic conductivity of the underlying subsurface materials. The test results are summarized in the following table. The field percolation test results are presented in Appendix C.

FIELD PERCOLATION TEST RESULTS				
<u>Location</u>	<u>Permeability Test Type</u>	<u>Test Depth (feet)</u>	<u>Test Duration (minutes)</u>	<u>Hydraulic Conductivity, k (feet/minute)</u>
Boring No. 1 (Kaneohe Side)	Constant Head	16.5	20.0	3.2×10^{-2}
	Falling Head		6.0	5.8×10^{-3}
	Constant Head	21.5	20.0	3.8×10^{-2}
	Falling Head		10.5	3.2×10^{-3}
Boring No. 3 (Kahuku Side)	Constant Head	17.0	20.0	7.8×10^{-2}
	Falling Head		3.0	5.2×10^{-3}
	Constant Head	22.0	20.0	4.2×10^{-2}
	Falling Head		10.0	9.4×10^{-4}

In general, the calculated k-values for the tests indicate the subsurface materials encountered at the two boring locations may be considered moderately to highly permeable in terms of water transmission.

END OF SITE CHARACTERIZATION

SECTION 3. DISCUSSION AND RECOMMENDATIONS

The project site is underlain by fills placed over soft to stiff alluvial soils overlying dense/stiff conglomerate, saprolitic soils and basalt formation at greater depths. Groundwater was encountered in the borings at depths of about 5.9 to 10 feet below the existing ground surface.

Based on the subsurface conditions encountered, the estimated scour depth, and the foundation loads provided, we recommend utilizing a deep foundation system consisting of drilled shafts to support the replacement bridge structure. In general, we recommend utilizing a nominal shaft diameter of 4 feet embedded into the dense old alluvium, conglomerate and/or basalt formation to support the abutment structures. The drilled shaft foundations would derive support principally from adhesion between the shaft and the dense older alluvium, conglomerate and/or basalt formation encountered in the borings.

It should be noted that potentially difficult drilling conditions likely will be encountered during installation of the drilled shafts in the stream channel due to the presence of the very loose sandy recent alluvium and the boulders and cobbles in the subsurface. Temporary steel casings will likely be required to reduce the potential for caving-in of the drilled holes during the drilling operation for the shafts at the abutment locations. Special drilling tools will be required to advance the drilled holes considering the presence of dense basaltic boulders and cobbles and hard basalt formation at the site. Detailed discussions and recommendations for design of the bridge structure are presented in the following sections.

3.1 General Information

Based on the information provided, the new replacement bridge structure will be a one-span bridge spanning approximately 110 feet from abutment to abutment. Based on information provided by the project structural engineer, general information and the foundation loads pertaining to the new bridge structure are presented in the following table.

FOUNDATION LOADING INFORMATION							
<u>Location</u>	<u>Loading Condition</u>	<u>Axial Compression</u> (kips)	<u>Longitudinal Shear</u> (kips)	<u>Transverse Shear</u> (kips)	<u>Longitudinal Moment</u> (kip-feet)	<u>Transverse Moment</u> (kip-feet)	<u>Torsional Moment</u> (kip-feet)
South Abutment (Kaneohe Side)	Strength I Limit State	2,623	253	0	4,898	3,844	608
North Abutment (Kahuku Side)	Strength I Limit State	2,623	253	0	4,898	4,648	736
South Abutment (Kaneohe Side)	Extreme Event Limit State	2,265	806	537	9,551	4,054	1,448
North Abutment (Kahuku Side)	Extreme Event Limit State	2,257	774	544	9,531	4,839	1,596

3.2 Seismic Design Considerations

Based on the design criteria provided by the State of Hawaii - Department of Transportation, Highways Division, the Kaipapau Stream Bridge Replacement project will need to be designed based on a peak horizontal bedrock acceleration (PBA) coefficient of 0.18g. Based on the average penetration resistance of the subsurface materials encountered in the borings and the geologic setting in the area, the project site may be classified as a "Stiff Soil" profile for seismic design considerations. Therefore, the project site may be classified as and designed based on a Site Class D soil profile based on Table No. 3.10.3.1-1 of the 2008 Interim Revisions to the AASHTO LRFD Bridge Design Specifications.

When seismic waves propagate through a soil profile, the seismic shear waves are usually intensified and amplified depending on the thickness and properties of the soils. Based a Site Class D soil profile, we estimate the peak ground acceleration (PGA) at the ground surface may be amplified to about 0.26g based on a peak bedrock acceleration (PBA) of 0.18g.

3.3 Stream/Channel Material for Scour Analysis

One of the most common causes of bridge failure stems from scouring of bridge foundations from flood or other water flow damage. Therefore, the foundation design of the bridge structure will need to take into consideration the potential for stream scour.

Scour is the result of erosive action of flowing water, excavating and carrying material away from the bed and banks of streams/channels. Total scour over a period of time generally consists of three components: 1) Aggregation and Degradation; 2) Contraction Scour; and 3) Local Scour. The rates of scour depend on a number of factors such as the shape and dimensions of a pier or abutment, depth of flow, velocity of approach flow, size and gradation of stream/channel bed material, and bed configuration.

One of the factors affecting the scour depth is the grain size characteristics of the stream bed material. The median diameter of the stream bed material (D_{50}), in conjunction with the depth of flow and flow velocity, is used to calculate fall velocity of stream bed materials in scour depth analysis. In order to evaluate the size and gradation of the stream bed material for scour depth analysis at the bridge location, soil samples from the boring (Boring No. 2) within the stream channel were retrieved for laboratory analysis. The stream bed materials generally consist of sands and gravel. Sieve analysis tests were performed on the recovered soil samples to provide the grain size distribution of the materials. Based on the laboratory test results, the median diameter of the stream bed material (D_{50}) at the replacement bridge structure was approximately 4 to 10 millimeters.

We understand that the total scour elevation for the 100-year storm event is elevation -8 feet MSL for the bridge abutments. For the Strength Limit State, 100 percent of the 100-year scour depth was used in the analysis. As suggested by HDOT, 25 percent of the 100-year scour depth was used in the Extreme Event Limit State analysis. The foundation design recommendations presented in the following sections of this report have incorporated these potential scour depths for the replacement bridge structure.

3.4 Drilled Shaft Foundations

Based on our field exploration, the project site is underlain by fills placed over alluvial soils overlying dense/stiff conglomerate, saprolitic soils and basalt formation at greater depths. Groundwater was encountered in the borings at depths of about 5.9 to 10 feet below the existing ground surface. Based on the subsurface conditions encountered, estimated scour depth elevation, and the foundation loads presented above, we recommend using drilled shaft foundations with a nominal diameter of 4 feet to support the proposed replacement bridge structure. The drilled shaft foundations would derive support principally from adhesion between the drilled shaft and the alluvium and basalt formation encountered in the borings. The contribution from end bearing of the drilled shafts has been discounted in our analyses due to the difficulties of obtaining a clean bottom for end-bearing shafts in these subsurface conditions during construction.

Based on our field exploration, engineering analyses, and the above assumptions, we recommend using drilled shafts with the following compressive load capacities for the extreme event and strength limit states based on Load and Resistance Factor Design (LRFD) methods for design of highway bridges. For the strength limit state, a resistance factor of 0.45 has been applied to the extreme event limit state capacities for design of the drilled shaft foundations. Based on the spacing of the drilled shafts (3.5 to 4 diameters center-to-center), efficiency factors of 0.75 to 0.82 are applied to the extreme event and strength limit state capacities for the shaft group presented in the following table. Bottom of footing elevations of +2.40 and +3.52 MSL were used in the analysis for Abutment Nos. 1 and 2, respectively.

FOUNDATION LAYOUT AND DRILLED SHAFT CAPACITIES						
<u>Location</u>	<u>Shaft Identification</u>	<u>Shaft Diameter</u> (feet)	<u>Drilled Shaft Tip Elev.</u> (feet MSL)	<u>Compressive Load Capacity Per Drilled Shaft</u> (kips)		
				<u>Unfactored Single Shaft Capacity</u>	<u>Extreme Event Limit State</u>	<u>Strength Limit State</u>
South Abutment (Kaneohe Side)	Mauka Shaft	4	-79.6	2,620	1,960	885
South Abutment (Kaneohe Side)	Center Two Shafts	4	-71.6	2,065	1,550	700
South Abutment (Kaneohe Side)	Makai Shaft	4	-67.6	1,695	1,360	610
North Abutment (Kahuku Side)	Mauka Shaft	4	-64.5	2,745	2,060	925
North Abutment (Kahuku Side)	Center Two Shafts	4	-54.5	2,050	1,540	695
North Abutment (Kahuku Side)	Makai Shaft	4	-48.5	1,535	1,225	555

3.4.1 Uplift Load Resistance

In general, uplift loads may be resisted by a combination of the dead weight of the drilled shaft and by shear along the shaft surface and the adjacent soils. We recommend using following uplift load capacities for the extreme event and strength limit states. For the strength limit state, a resistance factor of 0.35 has been applied to the extreme event limit state capacities for design of the drilled shaft foundations. The uplift load capacities provided also include the weight of the drilled shaft. The project structural engineer should check the structural capacity of the shaft member in tension.

UPLIFT LOAD CAPACITIES FOR DRILLED SHAFT FOUNDATIONS				
<u>Location</u>	<u>Shaft Identification</u>	<u>Drilled Shaft Diameter (feet)</u>	<u>Uplift Load Capacity Per Drilled Shaft (kips)</u>	
			<u>Extreme Event Limit State</u>	<u>Strength Limit State</u>
South Abutment (Kaneohe Side)	Mauka Shaft	4	2,000	700
South Abutment (Kaneohe Side)	Center Two Shafts	4	1,545	540
South Abutment (Kaneohe Side)	Makai Shaft	4	1,345	470
North Abutment (Kahuku Side)	Mauka Shaft	4	2,060	720
North Abutment (Kahuku Side)	Center Two Shafts	4	1,545	540
North Abutment (Kahuku Side)	Makai Shaft	4	1,230	430

3.4.2 Lateral Load Resistance

In general, lateral load resistance of drilled shafts is a function of the stiffness of the surrounding soil, the stiffness of the shaft, allowable deflection at the top of shaft, and induced moment in the shaft. The lateral load analyses were performed using the "GROUP" program. The program solves for deflection and bending moment along several deep foundation elements under lateral loads as a function of depth. The analysis was carried out with the use of non-linear "p-y" curves to represent soil moduli. The lateral deflection was then computed using the appropriate soil moduli at various depths.

Based on the available plan provided, the drilled shafts will be spaced at a minimum of 3.5 to 4 times the diameter of the shaft from center-to-center. Therefore, the effect of group action was considered in our lateral load analyses by including an efficiency factor in the direction of loading. Based on the anticipated load acting at the top of the drilled shaft group, the lateral deflection at the top of the drilled shaft group, and the maximum induced moments and shears are presented in the table below.

LATERAL DEFLECTION AND MAXIMUM INDUCED MOMENT IN THE DRILLED SHAFT FOUNDATIONS				
<u>Location</u>	<u>Loading Condition</u>	<u>Lateral Deflection (inches)</u>	<u>Maximum Moment Induced (kips-feet)</u>	<u>Maximum Shear Induced (kips)</u>
South Abutment (Kaneohe Side)	Strength I Limit State	0.1	1,475	83
North Abutment (Kahuku Side)		0.1	1,430	79
South Abutment (Kaneohe Side)	Extreme Event Limit State – Longitudinal	0.4	2,470	209
South Abutment (Kaneohe Side)	Extreme Event Limit State – Transverse	0.5	1,405	147
North Abutment (Kahuku Side)	Extreme Event Limit State – Longitudinal	0.4	2,445	199
North Abutment (Kahuku Side)	Extreme Event Limit State – Transverse	0.6	1,460	209

3.4.3 Foundation Settlements

Settlement of the drilled shaft foundations would result primarily from elastic compression of the drilled shaft and subgrade response. We estimate the total settlement of the drilled shaft supported foundation to be less than 0.5 inches with differential settlements between drilled shafts not exceeding about one-half that amount. We believe that these settlements are essentially elastic and should occur as the loads are applied.

3.4.4 Construction Considerations

The performance of drilled shafts depends significantly upon the contractor's method of construction and construction procedures. As a result of these potential

variations, a Geolabs representative should be present to observe the installation of drilled shafts during construction. In our opinion, the following may have a significant impact on the effectiveness and cost of the drilled shaft foundations.

Based on our field exploration, the abutment locations are underlain by very loose recent alluvium and dense cobbles and gravel with some boulders. Due to the presence of very loose soils, we anticipate that caving-in of the materials are highly likely during the drilling operations. To reduce the potential for caving-in of the drilled holes, temporary casing of the drilled holes should be provided during the drilled shaft installation. Care should be exercised during removal of the temporary casing to reduce the potential for "necking" of the drilled shaft. Therefore, a minimum 5-foot head of concrete above the bottom of the casing or adequate concrete head to counter hydrostatic pressures from the groundwater should be maintained during removal of the casing. The anticipated shallow groundwater levels at the bridge location also may pose some construction difficulties because proper observation of the sides and bottoms of the drilled shaft may not be possible.

It should be noted that dense basaltic cobbles and gravel with boulders and hard basalt formation were encountered in the borings. Therefore, special drilling tools for coring into the basaltic cobbles, boulders and basalt formation will be required. Appropriate measures also will be needed to avoid dislodging the boulders into the drilled shaft hole during the drilling and shaft installation process.

The drilled shaft contractor will need to demonstrate that the proposed drilling equipment (and coring tools) and construction methodology will be capable of installing the drilled shafts to the recommended depths and dimensions by performance of a trial shaft program. We recommend the trial shaft extend to a depth of at least 100 feet below the ground surface.

3.4.5 Workmanship

The load carrying capacities of drilled shafts depend, to a large extent, on the contact between the drilled shafts and the surrounding subsurface materials.

Therefore, proper construction techniques are important. The contractor should exercise care in drilling the shaft holes, installation of the temporary casing, placing concrete into the holes, and removal of the temporary casing.

Because of the shallow groundwater conditions at the site, concrete placement by tremie methods will be required during construction of the drilled shafts. The concrete should be placed in a suitable manner by displacing the water in an upward fashion from the bottom of the drilled hole. A low-shrink concrete mix with high slump (7 to 9-inch slump range) should be used to provide close contact between the drilled shafts and the surrounding soils. In addition, the maximum particle size of the aggregates in the concrete should be limited to 0.375 inches. The concrete should be placed in a suitable manner to reduce the potential for segregation of the aggregates from the concrete mix, and the concrete should be deposited into the drilled hole by pumping through a solid tremie pipe. A Geolabs representative should be present to observe the drilled shaft installation during construction because relatively high compressive load capacities are recommended for these drilled shafts.

3.4.6 Trial Shaft Program

A trial shaft program is normally required and highly recommended for bridge projects. Considering the diameter and structural load capacities of the drilled shafts, we recommend undertaking a trial shaft program, including the performance of an instrumented load test, to fulfill the following objectives:

- To examine the adequacy of the methods and equipment proposed by the contractor to install the drilled shafts through the loose alluvial soils, into the conglomerate layers consisting of basaltic cobbles and gravel with some boulders, and into the hard basalt formation.
- To confirm or modify the estimated tip elevations of the drilled shafts.
- To assess the contractor's method of placing and extracting the temporary casing for the drilled shaft.
- To assess the contractor's method of tremmie concrete placement.

To achieve these objectives, we recommend that the trial shaft program consist of drilling a 4-foot diameter trial shaft extending to a depth of at least 100 feet below the existing ground surface at a location near the north abutment. The location of the trial shaft should be near, but outside of, the abutment foundations. After drilling the trial shaft, the trial shaft should be filled with concrete similar to a production drilled shaft. In addition, we recommend constructing a separate load test shaft for load testing purposes. The load test shaft should be structurally reinforced and instrumented with embedment strain gauges for load testing. The embedment strain gauges should be placed starting from the bottom at an elevation of about 5 feet above the tip of the trial shaft and subsequently at 5-foot intervals, as shown on the Drilled Shaft Load Test Detail, Plate 4.

Due to the high capacities recommended for the drilled shafts, a conventional load test would not be practical and would be costly to conduct. Therefore, a bi-directional axial load test should be conducted on the reinforced load test shaft using an expandable base load cell (Osterberg Load Cell). The expandable base load cell will need to be attached to the reinforcing cage prior to lowering the reinforcing cage in place. The drilled shaft load test should be performed in general accordance with the Quick Load Test Method of ASTM D1143. In general, the load test shaft should be loaded at increments of about 100 to 200 kips and should be held for a minimum of 12 hours at or near failure to evaluate the potential for creep effects. The load test shaft should be loaded to failure to evaluate the ultimate side shear resistance of the trial shaft. Installation of the expandable base load cell and embedment strain gauges, performance of the bi-directional axial load test, and analyses of the load test data should be performed by a qualified professional experienced in these types of load testing procedures.

Considering the specialized nature of the trial shaft program, a Geolabs representative should be present during the trial shaft and load testing program to evaluate the contractor's method of drilled shaft installation and to evaluate the subsurface materials encountered. In addition, Geolabs should observe the instrumented load test on the reinforced load test shaft. It should be noted that

the drilled shaft design was developed from our analyses using the field exploration data. Therefore, observation of the drilled shaft installation operations by Geolabs is a vital part of the foundation design to confirm the design assumptions.

3.4.7 Non-Destructive Integrity Testing

Based on the critical nature of the drilled shaft foundations for the replacement bridge structure, we recommend conducting non-destructive integrity testing on the production drilled shafts for the project. Crosshole Sonic Logging (CSL) is one of the non-destructive integrity testing methods that have been gaining widespread use and acceptance for integrity testing of drilled shafts.

Crosshole Sonic Logging techniques are based on the propagation of sound waves through concrete. In general, the actual velocity of sound wave propagation in concrete is dependent on the concrete material properties, geometry of the element and wavelength of the sound waves. When ultrasonic frequencies are generated, Pressure (P) waves and Shear (S) waves travel through the concrete. If anomalies are contained in the concrete, the anomalies will reduce the P-wave travel velocity in the concrete. Anomalies in the drilled shaft concrete may include soil particles, gravel, water, voids, contaminated concrete, and highly segregated constituent particles.

The transit time of an ultrasonic P-wave signal may be measured between an ultrasonic transmitter and receiver in two parallel water-filled access tubes placed into the concrete during construction. The P-wave velocity can be obtained by dividing the measured transit time from the distance between the transmitter and receiver. Therefore, anomalies may be detected (if they exist).

In general, the access tubes should be securely attached to the interior of the reinforcing cage as near to parallel as possible in the drilled shaft. We recommend casting a minimum of four access tubes into the concrete of the 4-foot diameter drilled shafts. Details are shown on the Access Tube Detail for Crosshole Sonic Logging Test, Plate 5.

In addition, the access tubes should extend from the bottom of the drilled shaft reinforcing cage to at least 3.5 feet above the top of the shaft. It is imperative that joints required to achieve the full length of the access tubes should be watertight. The contractor is responsible for taking extra care to prevent damage of the access tubes during the placement of the reinforcing cage into the drilled hole. The tubes should be filled with potable water as soon as possible after concrete placement, but water filling of the access tubes should not be later than 4 hours after the concrete placement. Subsequently, the top of the access tubes should be capped with watertight caps.

The Crosshole Sonic Logging (CSL) test of drilled shafts should be conducted after at least 7 days of curing time, but no later than 28 days after concrete placement. In addition, the CSL test of drilled shafts should be performed in general accordance with ASTM D6760. In the event that a drilled shaft is found to have significant anomalies and/or is suspected to be defective based on the CSL testing and/or field observations, the drilled shaft should be cored to evaluate the integrity of the concrete in the drilled shaft. The coring location within the drilled shaft should be determined by our representative, who should be present to observe the installation of the drilled shafts. After completion of the crosshole sonic logging of the drilled shafts, all the access tubes should be filled with grout of the same strength as the drilled shaft concrete.

3.5 Structure Approach Slabs

We anticipate that a relatively substantial excavation of about 10 feet deep followed by subsequent backfilling will be required in order to construct the abutment structures of the new replacement bridge. To reduce the potential for appreciable abrupt differential settlements between the drilled shaft supported bridge structure and the compacted backfills behind the abutment structures, we recommend providing structure approach slabs at the abutment locations. In general, the structure approach slabs should be at least 20 feet in length.

The structure approach slabs should be supported on a minimum of 8 inches of aggregate subbase course placed on a prepared subgrade. The subgrade should be

scarified to a depth of about 8 inches, moisture-conditioned to above the optimum moisture content, and compacted to no less than 95 percent relative compaction. The aggregate subbase course should also be moisture conditioned to above the optimum moisture content and compacted to at least 95 percent relative compaction. Relative compaction refers to the in-place dry density of soil expressed as a percentage of the maximum dry density of the same soil established in accordance with AASHTO T-180 (or ASTM D1557). Optimum moisture is the water content (percentage by dry weight) corresponding to the maximum dry density.

3.6 Retaining Structures

Based on the information provided, we understand retaining structures, such as the abutment walls and wing walls, on the order of about 10 feet in height will be required for the replacement bridge project. In general, foundations for the abutment structure and wing walls (structural elements attached to the bridge structure) should be designed based on the recommendations for support of the bridge structure (drilled shaft foundations). The following guidelines may be used in designing the retaining structures for this project.

3.6.1 Static Lateral Earth Pressures

The abutment walls and wing walls for the replacement bridge should be designed to resist the lateral earth pressures due to the adjacent soils and surcharge effects caused by loads adjacent to the abutment and wing walls. The recommended lateral earth pressures for design of the retaining structures, expressed in equivalent fluid pressures of pounds per square foot per foot of depth (pcf), are presented in the following table.

LATERAL EARTH PRESSURES FOR DESIGN OF RETAINING STRUCTURES			
<u>Backfill Condition</u>	<u>Earth Pressure Component</u>	<u>Active (pcf)</u>	<u>At-Rest (pcf)</u>
Level Backfill	Above Groundwater	40	58
	Below Groundwater	80	88

Backfill behind the retaining structures (above the groundwater level) may consist of the on-site soils or select granular fills (Type A Structure Backfill) compacted to at least 90 percent relative compaction. Because shallow groundwater conditions are anticipated, backfill materials below the groundwater level should consist of free-draining granular materials, such as AASHTO M43, No. 67 gradation (ASTM C 33, No. 67 gradation), wrapped on all sides with non-woven filter fabric (Mirafi 180N or equivalent). The free-draining granular materials should be used up to a level of about 12 inches above the groundwater level to facilitate compaction of the backfill materials.

In general, an active condition may be used for gravity retaining walls or walls that are free to deflect by as much as 0.5 percent of the wall height. If the tops of walls are not free to deflect beyond this degree, or are restrained, the walls should be designed for the at-rest condition. These lateral earth pressures do not include hydrostatic pressures that might be caused by groundwater trapped behind the walls.

Surcharge stresses due to areal surcharges, line loads, and point loads within a horizontal distance equal to the depth of the wall should be considered in the design. For uniform surcharge stresses imposed on the loaded side of the wall, a rectangular distribution with uniform pressure equal to 36 percent of the vertical surcharge pressure acting over the entire height of the wall, which is free to deflect (cantilever), may be used in design. For walls that are restrained, a rectangular distribution equal to 53 percent of the vertical surcharge pressure acting over the entire height of the wall may be used for design. Additional analyses during design may be needed to evaluate the surcharge effects of point loads and line loads.

3.6.2 Dynamic Lateral Earth Forces

We understand dynamic lateral earth forces will need to be considered in the design of the retaining structures based on LRFD methods. An appropriately reduced factor of safety may be used when dynamic lateral earth forces are accounted for in the design of retaining structures. In general, a force due to dynamic lateral earth pressures on the retaining structure will increase with

decreased lateral movement of the structure. The table below summarizes the dynamic lateral earth forces acting on the abutment and wing walls in the event of an earthquake producing a peak ground acceleration of about 0.26g versus various wall displacements.

DYNAMIC LATERAL EARTH FORCES FOR RETAINING STRUCTURES	
<u>Allowable Lateral Wall Movement</u> (inches)	<u>Dynamic Lateral Earth Forces</u> (H ² pounds per linear foot)
0.5	19.6
1.0	14.8
1.5	11.5
2.0	8.1
2.5	5.8

It should be noted that the above table only applies to level backfill conditions, where H is the height of the wall in feet. The resultant force should be assumed to act through the mid-height of the wall. The total lateral earth forces presented above includes both static and dynamic lateral earth pressures.

3.6.3 Drainage

Retaining structures should be well drained to reduce the build-up of hydrostatic pressures. A typical drainage system should consist of permeable material, such as AASHTO M43, No. 67 gradation material, placed near the bottom and along the length of the wall discharging to an appropriate outlet or weep holes. As an alternative, the drainage system may consist of about 1 cubic foot of permeable material, such as AASHTO M43, No. 67 gradation material, wrapped with non-woven, filter fabric at each of the weep hole locations. The weep holes should be spaced not more than 8 feet apart.

Backfill behind the permeable drainage zone should consist of Type A Structure Backfill Material conforming to Section 703.20 of the State of Hawaii Standard Specifications for Road and Bridge Construction, 2005 (HSS). Unless covered by concrete slabs or pavements, the upper 12 inches of backfill should consist of relatively impervious material to reduce the potential for significant water infiltration

behind the walls. In addition, the backfill from the bottom of the wall to about the elevation of the weepholes should consist of relatively impervious soil backfill, such as the on-site clayey soils, to reduce the potential for excess water infiltration into the foundation materials.

3.7 Bypass Roadway

A temporary bypass road will be required during the construction of the replacement bridge structure. The bypass road will include a stream crossing structure with a span of about 91 feet supported on a center pier and abutments at each end of the structure. We understand that an Acrow type of bridge structure will be used. In addition, we understand that scour protection will be provided for the center pier footing and that scour need not be considered for the temporary bridge foundations.

We anticipate that the center pier footing will be bearing on loose to medium dense silty sands and gravels and cobbles and boulders. Should loose/soft subsoils be encountered at the footing level, the loose/soft materials should be over-excavated a minimum of 24 inches and replaced with stabilization layer consisting of No. 2 Coarse rock wrapped with a filter fabric (Mirafi 180N). Bearing resistance of up to 4,500 and 2,000 pounds per square foot (psf) may be used for the Extreme Event and Strength Limit States, respectively. For the Service Limit State, a bearing resistance of up to 1,500 psf may be used.

For the temporary bridge abutments, we anticipate that the abutment footings will be bearing on medium stiff silty clay/clayey silt. The bearing resistance provided for the center pier footing may be used for the abutment footings.

3.8 Temporary Segmental Retaining Wall

A temporary segmental retaining wall will be constructed for the bypass roadway. In general, the segmental retaining wall system is a composite wall system, which utilizes high-density polyethylene, or other reinforcing elements, to reinforce the backfill zone and improve the shear strength of the reinforced soil zone. This composite system essentially forms a gravity wall structure with an ability to tolerate significant total and differential settlements.

We believe that the reinforced fill material for the segmental retaining wall should consist of imported select granular fill materials. In general, the imported select granular fill materials should be well graded from coarse to fine with particles no larger than 3 inches in largest dimension. The material should also contain less than 15 percent particles passing the No. 200 sieve. The material should have a California Bearing Ratio (CBR) value of 25 or higher and a swell potential of one percent or less when tested in accordance with ASTM D1883.

In addition, the reinforced fill material (imported select granular fill materials) should have an angle of internal friction of at least 34 degrees when tested by the standard direct shear test (ASTM D3080). The sample to be tested should be compacted to 95 percent relative compaction at moisture contents above the optimum.

Reinforced fill materials should be placed in level loose lifts not exceeding 8 inches in loose thickness and be compacted to at least 95 percent of the maximum dry density established in accordance with AASHTO T-180 at moisture contents above the optimum.

Geogrids should consist of geosynthetic reinforcement material having regular and defined open areas. The geogrid structure should be select high density polyethylene or polypropylene resin. During wall construction, the geogrids should be oriented with the highest strength axis perpendicular to the wall alignment. The geogrid should lay horizontally on compacted backfill, pulled taut, and anchored before placing backfill on the geogrid.

The geogrid should be continuous throughout the geogrid embedment lengths. Splices to connect two sections of geogrids may be used provided the splice connector is capable of providing 100 percent load transfer between the two geogrid sections.

Based on our analysis, a minimum base width to wall height ratio of at least 1.33 is recommended for the segmental retaining wall structure.

3.9 Site Grading

Based on the existing topography and the design finished grades of the new bridge approaches, the extent of grading required to construct the proposed replacement bridge will consist of cuts and fills up to about 2 feet thick. In addition, we anticipate an excavation of about 10 feet deep followed by backfilling will be required for construction of the abutment and wing walls. In general, the site grading for the project should conform to Section 203 of the HSS and the site-specific recommendations contained in this report.

A Geolabs representative or a qualified personnel experienced in earthwork construction should observe the site grading operations to monitor whether undesirable materials are encountered during the excavation and scarification process, and to confirm whether the exposed soil conditions are similar to those encountered in our exploration.

In general, areas to receive fills should be cleared of vegetation and deleterious materials. The resulting grub/spoil materials should be disposed of properly off-site. Soft, weak, or yielding areas disclosed during clearing operations should be over-excavated to expose firm or dense ground, and the resulting excavation should be backfilled with general fill materials moisture-conditioned to above the optimum moisture content and compacted to a minimum of 90 percent relative compaction. After clearing and grubbing, the exposed subgrades should be scarified to a minimum depth of 8 inches, moisture-conditioned to above the optimum moisture content, and compacted to a minimum of 90 percent relative compaction. Relative compaction refers to the in-place dry density of soil expressed as a percentage of the maximum dry density of the same soil established in accordance with AASHTO T-180 (or ASTM D1557). Optimum moisture is the water content (percentage by dry weight) corresponding to the maximum dry density.

In general, the excavated on-site materials may be re-used as a source of general fill and backfill materials provided that they are free of organic materials and contain no lumps or rock fragments greater than 3 inches in largest dimension. It should be noted that the excavated soft clays and silts should not be used as a source of

general fill and backfill. Where used as general fill and backfill materials, the on-site materials should be moisture-conditioned to above the optimum moisture content, placed in level lifts not exceeding 8 inches in loose thickness, and compacted to a minimum of 90 percent relative compaction.

Imported material should consist of "select granular fill," such as crushed coral, basalt, or cinder sand. Select granular fill materials should be well graded from coarse to fine with particles no larger than 3 inches in largest dimension. Select granular fill should have a laboratory CBR value of 20 or more with a maximum swell value of 1 percent or less when tested in accordance with AASHTO T-193 (or ASTM D1883). In addition, select granular fill material should contain between 10 and 30 percent particles passing the No. 200 sieve. Imported materials should be brought to above the optimum moisture content and compacted to a minimum of 95 percent relative compaction. Surfaces should be finished to create smooth, unyielding subgrades and should be kept moist until covered by concrete slabs or pavements. Imported materials should be tested and approved prior to delivery to the project site for its intended use.

For backfill behind the abutment structure, the backfill material should consist of well-graded, granular fill material conforming to Type A Structure Backfill Material of Section 703.20 of the HSS. The material should be moisture-conditioned to above the optimum moisture content, placed in level loose lifts not exceeding 8 inches, and compacted to a minimum of 90 percent relative compaction. For backfill below the ground water level, free-draining granular material, such as AASHTO M43, No. 67 gradation, wrapped on all sides with non-woven filter fabric should be used. This free draining granular material should be used up to a level of about 12 inches above ground water level to facilitate compaction of the backfill materials.

3.10 Underground Water Line

Based on the plans provided, we understand that a 16-inch diameter water line will be installed along the downstream side of the bridge and will be connected to the existing water line system. It is anticipated that the trench for the underground water line generally will be excavated in the near-surface fills consisting of medium stiff silts and clays and recent alluvium. In general, we recommend providing granular bedding

consisting of 6 inches of free-draining granular materials (AASHTO M43 Size No. 67 gradation) below the pipes. If soft and/or loose soils (recent alluvium) are exposed at or near the invert of the pipes, an additional 24 inches of free-draining gravel wrapped in a non-woven filter fabric (Mirafi 180N or equivalent) should be provided below the bedding layer for uniform support.

Free-draining granular materials, such as AASHTO M43, No. 67 gradation, also should be used for the initial trench backfill up to about 12 inches above the pipes or about 12 inches above the groundwater level to provide adequate support around the pipes. It is critical to use free-draining materials to reduce the potential for formation of voids below the haunches of pipes and to provide adequate support around the sides of the pipes. Improper trench backfill could result in backfill settlement and pipe damage.

The upper portion of the trench backfill from the level 12 inches above the pipes (or groundwater level) to the top of the subgrade may consist of the excavated on-site soils with a maximum particle size of 6 inches (excluding the very soft or loose soils). The backfill material should be moisture-conditioned to above the optimum moisture content, placed in maximum 8-inch level loose lifts, and mechanically compacted to a minimum of 90 percent relative compaction to reduce the potential for significant future ground subsidence. Where trenches are below pavement areas, the upper 3 feet of the trench backfill below the pavement grade should be compacted to a minimum of 95 percent relative compaction.

3.11 Design Review

Drawings and specifications for the proposed construction should be forwarded to Geolabs for review and written comments prior to bid advertisement. This review is necessary to evaluate adherence of the plans and specifications to the intent of the foundation and earthwork recommendations provided herein. If this review is not made, Geolabs cannot assume responsibility for misinterpretation of the recommendations presented.

3.12 Post Design / Construction Observation Services

It is recommended to retain Geolabs for geotechnical engineering services during construction. The critical items of construction monitoring that require "Special Inspection" include observation of the drilled shaft foundation installation and testing, subgrade proof-rolling, and other aspects of the earthwork construction. This is to observe compliance with the intent of the design concepts, specifications, or recommendations and to expedite suggestions for design changes that may be required in the event that subsurface conditions differ from those anticipated at the time this report was prepared. The recommendations provided herein are contingent upon such observations. If the actual subsurface conditions encountered during construction are different from those assumed or considered herein, then appropriate design modifications should be made.

END OF DISCUSSION AND RECOMMENDATIONS

SECTION 4. LIMITATIONS

The analyses and recommendations submitted in this report are based in part upon information obtained from the field borings and bulk samples. Variations of conditions between and beyond the field borings and bulk samples may occur, and the nature and extent of these variations may not become evident until construction is underway. If variations then appear evident, it will be necessary to re-evaluate the recommendations presented in this report.

The field boring and bulk sample locations are approximate, having been estimated from the topographic survey transmitted by R.M. Towill Corporation on February 17, 2006. Elevations of the field borings were interpolated from the contour lines shown on the same plan. The boring locations and elevations should be considered accurate only to the degree implied by the methods used.

The stratification breaks shown on the Logs of Borings depict the approximate boundaries between soil/rock types and, as such, may denote a gradual transition. Water level data from the borings were measured at the times shown on the graphic representations and/or presented in the text herein. These data have been reviewed and interpretations made in the formulation of this report. However, it must be noted that fluctuation may occur due to variation in seasonal rainfall, and other factors.

This report has been prepared for the exclusive use of R.M. Towill Corporation and their client, State of Hawaii – Department of Transportation, Highways Division, for specific application to *Kaipapau Stream Bridge Replacement* project in accordance with generally accepted geotechnical engineering principles and practices. No warranty is expressed or implied.

This report has been prepared solely for the purpose of assisting the design engineers in the preparation of the design drawings for the bridge replacement project. Therefore, this report may not contain sufficient data, or the proper information, for use to form the basis for preparation of construction cost estimates or contract bidding. A contractor wishing to bid on this project should retain a competent geotechnical

engineer to assist in the interpretation of this report and/or performance of site-specific exploration for bid estimating purposes.

The owner/client should be aware that unanticipated soil conditions are commonly encountered. Unforeseen subsurface conditions, such as perched groundwater, soft deposits, hard layers or cavities, may occur in localized areas and may require additional probing or corrections in the field (which may result in construction delays) to attain a properly constructed project. Therefore, a sufficient contingency fund is recommended to accommodate these possible extra costs.

This geotechnical engineering exploration conducted at the project site was not intended to investigate the potential presence of hazardous materials existing at the site. It should be noted that the equipment, techniques, and personnel used to conduct a geo-environmental exploration differ substantially from those applied in geotechnical engineering.

END OF LIMITATIONS

CLOSURE

The following plates and appendices are attached and complete this report:

Project Location Map..... Plate 1
Site Plan..... Plate 2
Generalized Geologic Cross-Section A-A' Plate 3
Drilled Shaft Load Test Detail Plate 4
Access Tube Detail for Crosshole Sonic Logging Test Plate 5
Field Exploration Appendix A
Laboratory Tests Appendix B
Field Percolation Tests..... Appendix C
Core Photographs Appendix D

-ΩΩΩΩΩΩΩΩΩ-

Respectfully submitted,

GEOLABS, INC.

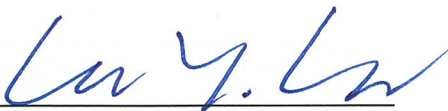
By 
Gerald Y. Seki, P.E.
Senior Project Engineer

CSM:RML:GS:mj

h:\5000 Series\5014-00A.gs4.doc

PLATES

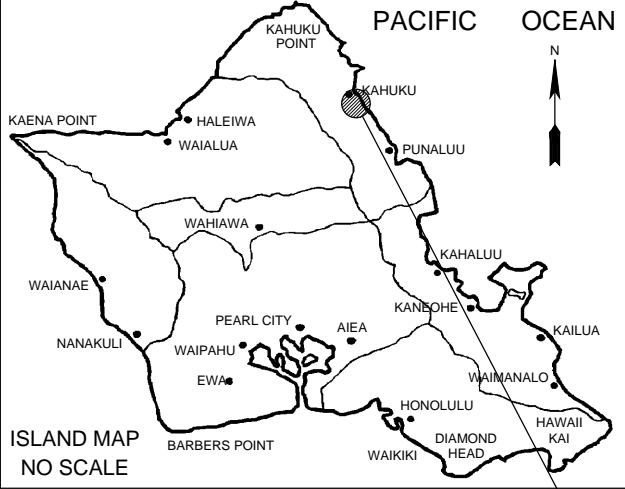
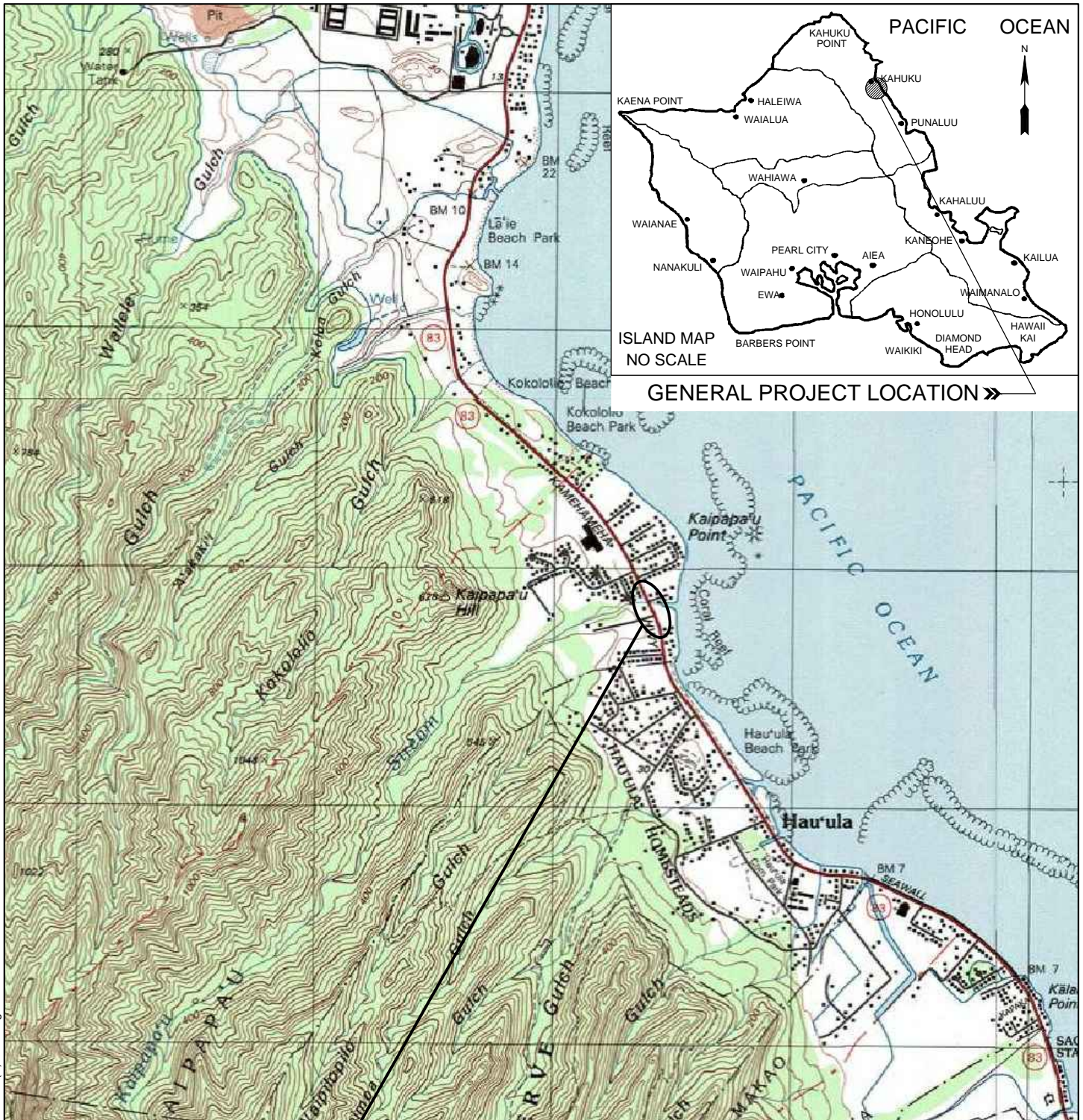

GENERAL PROJECT LOCATION

PROJECT LOCATION

PROJECT LOCATION MAP
KAMEHAMEHA HIGHWAY (ROUTE 83)
KAIPAPAU STREAM BRIDGE REPLACEMENT
KOOLAULOA, OAHU, HAWAII

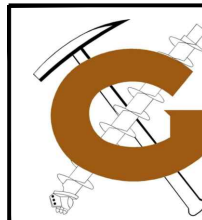
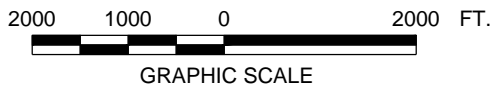

GEOLABS, INC.

Geotechnical Engineering

DATE	DRAWN BY	PLATE
AUGUST 2014	JRP	
SCALE	W.O.	1
1" = 2,000'	5014-00(A)	

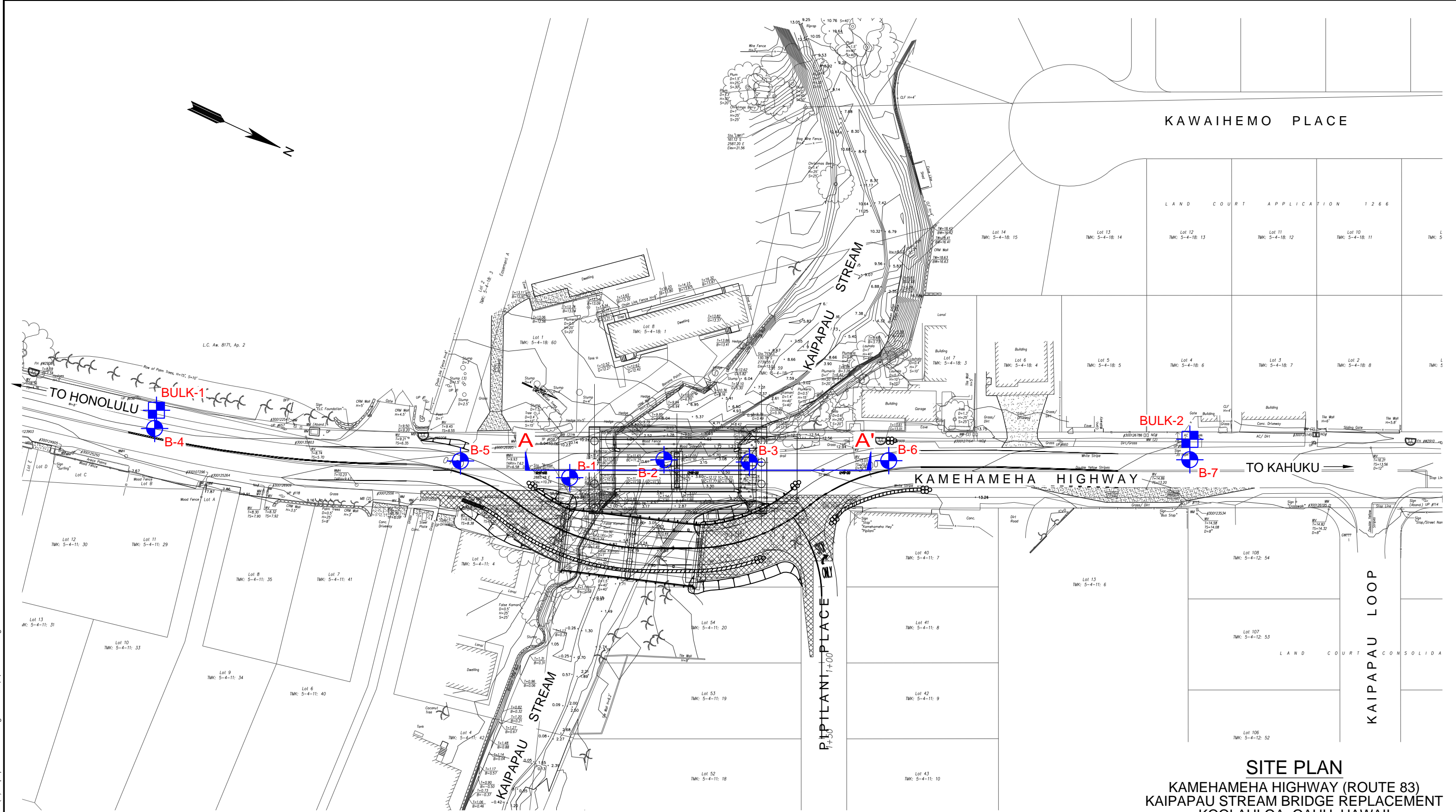

KAWAIHEMO PLACE



LAND COURT APPLICATION 1266

KAMEHAMEHA HIGHWAY

TO KAHUKU

KAIPAPAU LOOP

SITE PLAN
 KAMEHAMEHA HIGHWAY (ROUTE 83)
 KAIPAPAU STREAM BRIDGE REPLACEMENT
 KOOLAULO, OAHU, HAWAII

- LEGEND:**
-  APPROXIMATE BORING LOCATION
 -  APPROXIMATE BULK SAMPLE LOCATION

 GENERALIZED GEOLOGIC CROSS-SECTION

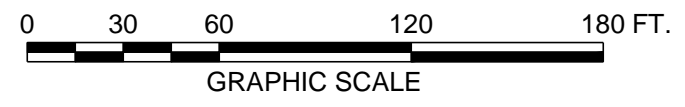

GEOLABS, INC.		
Geotechnical Engineering		
DATE	DRAWN BY	PLATE
AUGUST 2014	JRP	
SCALE	W.O.	
1" = 60'	5014-00(A)	2

User: JJP File Created: January 21, 2003 File Last Updated: August 05, 2014 8:21:16am
 File: T:\Drafting\9904\Working\5014-00(A)KaipapauStreamBridge\5014-00(A)SitePlan.dwg(SitePlan)

REFERENCE: SITE PLAN TRANSMITTED BY R. M. TOWILL CORPORATION ON FEBRUARY 17, 2006.

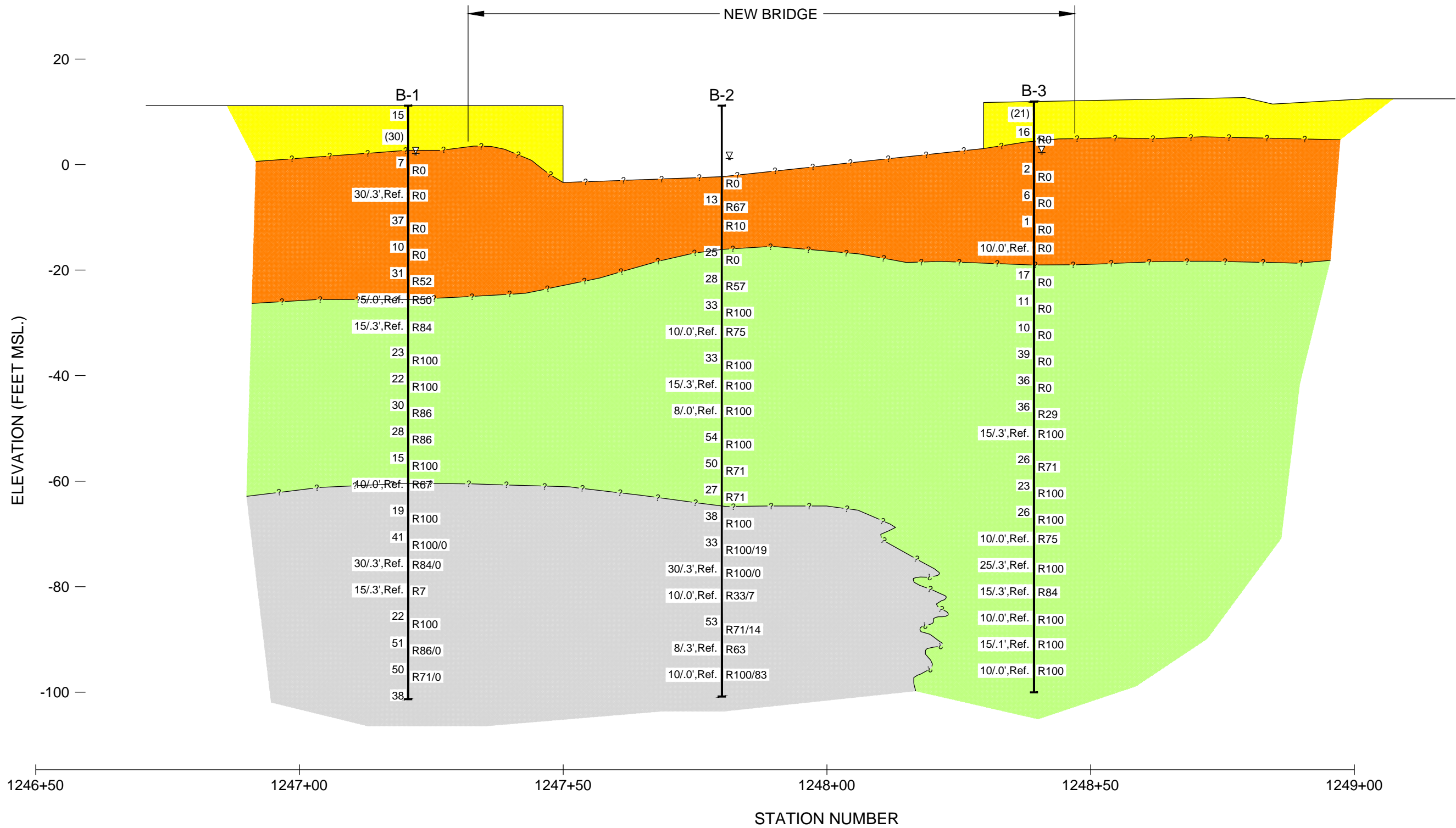

LEGEND:

- 20 BLOW COUNT REQUIRED FOR 12 INCHES OF PENETRATION OF A 2-INCH O.D. STANDARD PENETRATION SAMPLER
- (20) BLOW COUNT REQUIRED FOR 12 INCHES OF PENETRATION OF A 3-INCH O.D. MODIFIED CALIFORNIA SAMPLER
- R100/50 REC/RQD VALUES IN PERCENT
- FILL
- RECENT ALLUVIUM
- OLDER ALLUVIUM AND CONGLOMERATE
- SAPROLITE AND BASALT

GENERALIZED SUBSURFACE PROFILE
 KAMEHAMEHA HIGHWAY (ROUTE 83)
 KAIPAPAU STREAM BRIDGE REPLACEMENT
 KOOLAULO, OAHU, HAWAII



GEOLABS, INC.		
<i>Geotechnical Engineering</i>		
DATE AUGUST 2014	DRAWN BY JRP	PLATE 3
SCALE 1" = 20'	W.O. 5014-00	



NOTE: THE CONDITIONS ILLUSTRATED ARE BASED ON OUR BORINGS AND GEOLOGICAL INTERPRETATIONS. WHILE THESE ARE BELIEVED TO BE GENERALLY CORRECT, THE CONDITIONS MAY VARY LOCALLY FROM THOSE INDICATED.

CAD User: JJP File Created: April 23, 1998 File Last Updated: August 05, 2014 2:53:07pm
 File: T:\Drafting-9904\Working\5014-00\KaipapuStreamBridge\5014-00\DrilledShaftLoadTestDetail.dwg\Drilled Shaft Load Test Detail

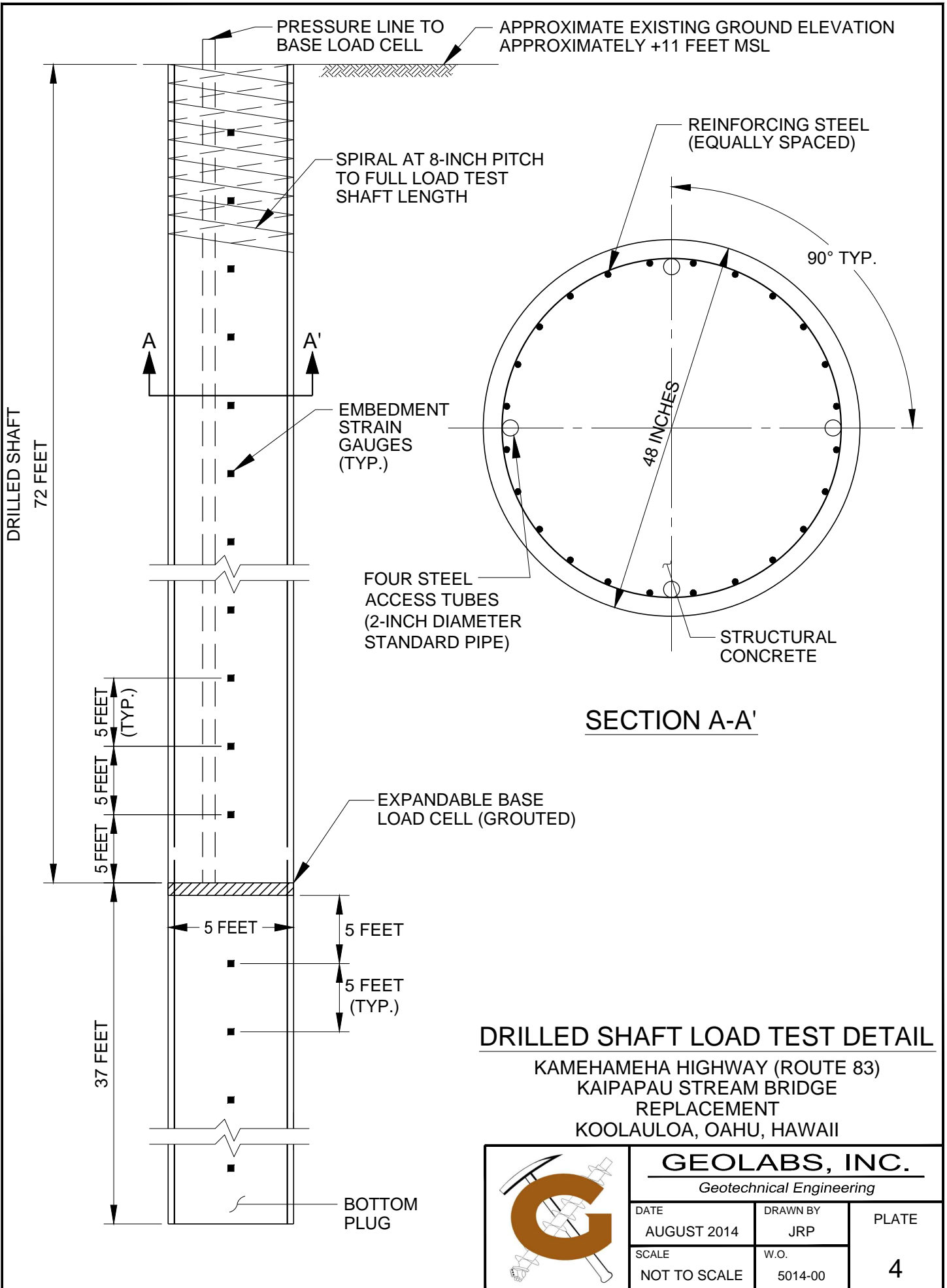

DRILLED SHAFT LOAD TEST DETAIL
 KAMEHAMEHA HIGHWAY (ROUTE 83)
 KAIPAPAU STREAM BRIDGE
 REPLACEMENT
 KOOLAULOA, OAHU, HAWAII



GEOLABS, INC. Geotechnical Engineering		
DATE AUGUST 2014	DRAWN BY JRP	PLATE 4
SCALE NOT TO SCALE	W.O. 5014-00	

CAD User: JJP File Created: April 23, 1988 File Last Updated: August 05, 2014 2:55:26pm
File: T:\Drafting-9904\Working\5014-00\KaipapauStreamBridge\5014-00\DrillShaft\AccessTubeDetail.dwg\Access Tube Detail

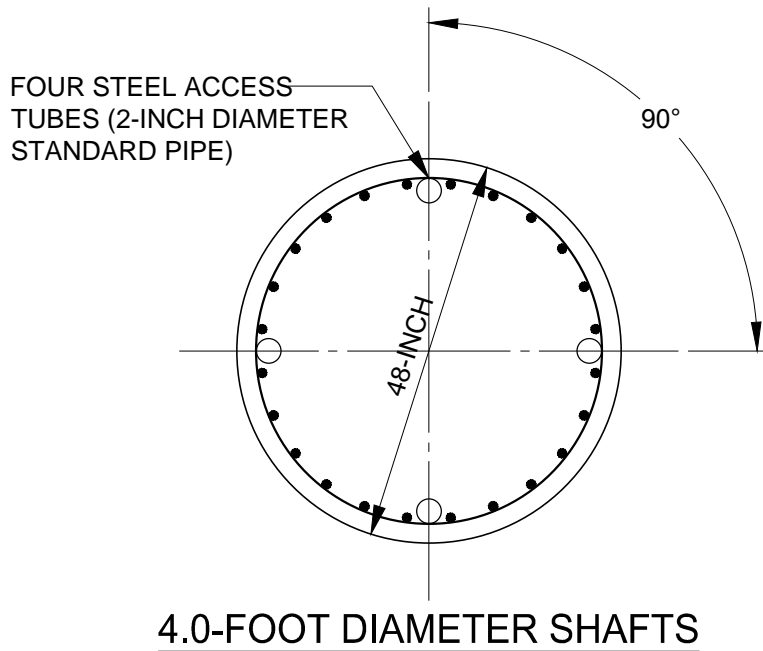

ACCESS TUBE DETAIL FOR CROSSHOLE SONIC LOGGING TEST

KAMEHAMEHA HIGHWAY (ROUTE 83)
KAIPAPAU STREAM BRIDGE
REPLACEMENT
KOOLAULOA, OAHU, HAWAII

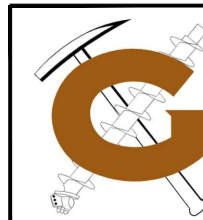

GEOLABS, INC.

Geotechnical Engineering

DATE	DRAWN BY	PLATE
AUGUST 2014	JRP	
SCALE	W.O.	5
NOT TO SCALE	5014-00	

APPENDIX A

APPENDIX A

Field Exploration

We explored the subsurface conditions by drilling and sampling seven borings to depths from approximately 13 to 112.5 feet below the existing ground surface. The borings were drilled with a truck-mounted drill rig equipped with auger equipment and coring tools at the approximate locations shown on the Site Plan, Plate 2.

Our geologist classified the materials encountered in the borings by visual and textural examination in the field and observed the field exploration operations on a near-continuous basis. These classifications were further reviewed by visual observation and testing in the laboratory. Soils were classified in general conformance with the Unified Soil Classification System, as shown on the Soil Log Legend, Plate A. Graphic representations of the materials encountered are presented on the Logs of Borings, Plates A-1 through A-7.

Relatively “undisturbed” soil samples were obtained in general accordance with ASTM D3550, Ring-Lined Barrel Sampling of Soils, by driving a 3-inch OD Modified California sampler with a 140-pound hammer falling 30 inches. In addition, some samples were obtained from the drilled borings in general accordance with ASTM D1586, Penetration Test and Split-Barrel Sampling of Soils, by driving a 2-inch OD standard penetration sampler using the same hammer and drop. The blow counts needed to drive the sampler the second and third 6 inches of an 18-inch or 24-inch drive are shown as the “Penetration Resistance” on the Logs of Borings at the appropriate sample depths.

Core samples of the rock materials (and boulders and cobbles) encountered at the site were obtained using diamond core drilling techniques in general accordance with ASTM D2113, Diamond Core Drilling for Site Investigation. Core drilling is a rotary drilling method that uses a hollow bit to cut into the rock formation. The rock material left in the hollow core of the bit is mechanically recovered for examination and description.

Recovery (REC) is used as a subjective guide to the interpretation of the relative quality of rock masses. Recovery is defined as the actual length of material recovered from a coring attempt versus the length of the core attempt. For example, if 3.7 feet of material is recovered from a 5.0-foot core run, the recovery would be 74 percent and would be shown on the Logs of Borings as REC = 74%.

The Rock Quality Designation (RQD) is a subjective guide to the relative quality of rock masses. RQD is defined as the percentage of the core run that is sound material in excess of 4 inches in length without discontinuities, discounting drilling induced fractures or breaks. If 2.0 feet of sound material is recovered from a 5.0-foot core run, the RQD would be 40 percent and would be shown on the Logs of Borings as RQD = 40%. Generally, the following is used to describe the relative quality of the rock, based on the "Practical Handbook of Physical Properties of Rocks and Minerals."

<u>Rock Quality</u>	<u>RQD</u> (%)
Very Poor	0 – 25
Poor	25 – 50
Fair	50 – 75
Good	75 – 90
Excellent	90 – 100



GEOLABS, INC.

Geotechnical Engineering

Soil Log Legend

UNIFIED SOIL CLASSIFICATION SYSTEM (USCS)

MAJOR DIVISIONS			USCS	TYPICAL DESCRIPTIONS	
COARSE-GRAINED SOILS MORE THAN 50% OF MATERIAL RETAINED ON NO. 200 SIEVE	GRAVELS MORE THAN 50% OF COARSE FRACTION RETAINED ON NO. 4 SIEVE	CLEAN GRAVELS LESS THAN 5% FINES		GW WELL-GRADED GRAVELS, GRAVEL-SAND MIXTURES, LITTLE OR NO FINES	
		GRAVELS WITH FINES MORE THAN 12% FINES		GP POORLY-GRADED GRAVELS, GRAVEL-SAND MIXTURES, LITTLE OR NO FINES	
		SANDS 50% OR MORE OF COARSE FRACTION PASSING THROUGH NO. 4 SIEVE	CLEAN SANDS LESS THAN 5% FINES		SW WELL-GRADED SANDS, GRAVELLY SANDS, LITTLE OR NO FINES
			SANDS WITH FINES MORE THAN 12% FINES		SP POORLY-GRADED SANDS, GRAVELLY SANDS, LITTLE OR NO FINES
	FINE-GRAINED SOILS 50% OR MORE OF MATERIAL PASSING THROUGH NO. 200 SIEVE	SILTS AND CLAYS LIQUID LIMIT LESS THAN 50		ML INORGANIC SILTS AND VERY FINE SANDS, ROCK FLOUR, SILTY OR CLAYEY FINE SANDS OR CLAYEY SILTS WITH SLIGHT PLASTICITY	
				CL INORGANIC CLAYS OF LOW TO MEDIUM PLASTICITY, GRAVELLY CLAYS, SANDY CLAYS, SILTY CLAYS, LEAN CLAYS	
				OL ORGANIC SILTS AND ORGANIC SILTY CLAYS OF LOW PLASTICITY	
		SILTS AND CLAYS LIQUID LIMIT 50 OR MORE		MH INORGANIC SILT, MICACEOUS OR DIATOMACEOUS FINE SAND OR SILTY SOILS	
CH INORGANIC CLAYS OF HIGH PLASTICITY					
OH ORGANIC CLAYS OF MEDIUM TO HIGH PLASTICITY, ORGANIC SILTS					
HIGHLY ORGANIC SOILS				PT PEAT, HUMUS, SWAMP SOILS WITH HIGH ORGANIC CONTENTS	

NOTE: DUAL SYMBOLS ARE USED TO INDICATE BORDERLINE SOIL CLASSIFICATIONS

LEGEND

- | | | | |
|--|--|-----|---|
| | (2-INCH) O.D. STANDARD PENETRATION TEST | LL | LIQUID LIMIT (NP=NON-PLASTIC) |
| | (3-INCH) O.D. MODIFIED CALIFORNIA SAMPLE | PI | PLASTICITY INDEX (NP=NON-PLASTIC) |
| | SHELBY TUBE SAMPLE | TV | TORVANE SHEAR (tsf) |
| | GRAB SAMPLE | PEN | POCKET PENETROMETER (tsf) |
| | CORE SAMPLE | UC | UNCONFINED COMPRESSION (psi) |
| | WATER LEVEL OBSERVED IN BORING | UU | UNCONSOLIDATED UNDRAINED TRIAXIAL COMPRESSION (ksf) |



GEOLABS, INC.

Geotechnical Engineering

KAMEHAMEHA HIGHWAY (ROUTE 83)
KAIPAPAU STREAM BRIDGE REPLACEMENT
KOOLAULOA, OAHU, HAWAII

Log of Boring

1

Laboratory			Field				Depth (feet)	Sample	Graphic	USCS	Description
Other Tests	Moisture Content (%)	Dry Density (pcf)	Core Recovery (%)	RQD (%)	Penetration Resistance (blows/foot)	Pocket Pen. (tsf)					
											Approximate Ground Surface Elevation (feet MSL): 11 *
	45				15		1.5			SW CH	6-inch ASPHALTIC CONCRETE Light tan GRAVELLY SAND (CORALLINE) with silt, dense, dry
	49	64			30		1.0	5			Brown with multi-color mottling SILTY CLAY with sand and highly weathered gravel (basaltic), medium stiff, damp grades with cobbles (basaltic)
	35		0		7			10		SM	Grayish dark brown SILTY SAND (BASALTIC) with well-rounded gravel (basaltic), loose (recent alluvium)
			0		30/3" Ref.			15			grades with cobbles (basaltic)
	10		0		37			20		GP	Brownish gray GRAVEL AND COBBLES (BASALTIC) in a silt matrix, dense
	29		0		10			25		SC	Brown with multi-color mottling CLAYEY SAND (BASALTIC) with gravel (basaltic), loose to medium dense
	33		52		31			30		GW	Brown with multi-color mottling SANDY ROUNDED GRAVEL (BASALTIC) in a silt matrix, dense
								35			grades with boulders (basaltic)

Date Started: August 21, 2006

Date Completed: August 22, 2006

Logged By: Y. Chiba

Total Depth: 112.5 feet

Work Order: 5014-00(A)

Water Level: ∇ 9.1 ft. 8/23/06 1000 HRS

Drill Rig: CME-75

Drilling Method: 4" Auger & PQ Coring

Driving Energy: 140 lb. wt., 30 in. drop

Plate

A - 1.1



GEOLABS, INC.

Geotechnical Engineering

KAMEHAMEHA HIGHWAY (ROUTE 83)
KAIPAPAU STREAM BRIDGE REPLACEMENT
KOOLAULOA, OAHU, HAWAII

Log of Boring

1

Laboratory			Field				Depth (feet)	Sample	Graphic	USCS	Description
Other Tests	Moisture Content (%)	Dry Density (pcf)	Core Recovery (%)	RQD (%)	Penetration Resistance (blows/foot)	Pocket Pen. (tsf)					
			50		5/0" Ref.				GW	(Continued from previous plate)	
			84		15/3" Ref.					Brown with multi-color mottling COBBLES AND GRAVEL (BASALTIC) in a clayey silt matrix, slightly cemented, dense (old alluvium)	
	45				23					grades to medium dense, breaks down to brown sandy silt	
			100								
	49				22						
			100								
	59				30						
			86								
	45				28						
			86								
	50				15						
			100			1.5			MH	Brown with multi-color mottling CLAYEY SILT with sand and some gravel (basaltic), medium	

BORING LOG 5014-00(A).GPJ GEOLABS.GDT 12/29/08

Date Started: August 21, 2006	Water Level: ∇ 9.1 ft. 8/23/06 1000 HRS	Plate A - 1.2
Date Completed: August 22, 2006		
Logged By: Y. Chiba	Drill Rig: CME-75	
Total Depth: 112.5 feet	Drilling Method: 4" Auger & PQ Coring	
Work Order: 5014-00(A)	Driving Energy: 140 lb. wt., 30 in. drop	



GEOLABS, INC.

Geotechnical Engineering

KAMEHAMEHA HIGHWAY (ROUTE 83)
KAIPAPAU STREAM BRIDGE REPLACEMENT
KOOLAULO, OAHU, HAWAII

Log of Boring

1

Laboratory			Field				Depth (feet)	Sample	Graphic	USCS	Description
Other Tests	Moisture Content (%)	Dry Density (pcf)	Core Recovery (%)	RQD (%)	Penetration Resistance (blows/foot)	Pocket Pen. (tsf)					
			67		10/0" Ref.				MH	stiff (residual soil) grades with moderately weathered boulders (basaltic) at 69.8 feet	
	49		100		19		75		ML	Grayish brown with multi-color mottling SILT with sand, medium stiff (saprolite)	
	74		100		41		80			grades to brown with multi-color mottling with clay	
			84	0	30/3" Ref.		85			Greenish gray with multi-color mottling BASALT , closely to severely fractured, highly to extremely weathered, medium hard (basalt formation)	
			7		15/3" Ref.		90		SC	Brown to gray with multi-color mottling CLAYEY SAND , medium dense (saprolite)	
	63		100		22		95				
	47		86	0	51		100				
							105			Gray with multi-color mottling BASALT , closely to severely fractured with some slickensided	

(Continued from previous plate)

Description

BORING LOG 5014-00(A).GPJ GEOLABS.GDT 12/29/08

Date Started: August 21, 2006	Water Level: ∇ 9.1 ft. 8/23/06 1000 HRS	Plate A - 1.3
Date Completed: August 22, 2006		
Logged By: Y. Chiba	Drill Rig: CME-75	
Total Depth: 112.5 feet	Drilling Method: 4" Auger & PQ Coring	
Work Order: 5014-00(A)	Driving Energy: 140 lb. wt., 30 in. drop	



GEOLABS, INC.

Geotechnical Engineering

KAMEHAMEHA HIGHWAY (ROUTE 83)
KAIPAPAU STREAM BRIDGE REPLACEMENT
KOOLAULOA, OAHU, HAWAII

Log of Boring

1

Laboratory			Field				Depth (feet)	Sample	Graphic	USCS	Description
Other Tests	Moisture Content (%)	Dry Density (pcf)	Core Recovery (%)	RQD (%)	Penetration Resistance (blows/foot)	Pocket Pen. (tsf)					
	47		71	0	50						(Continued from previous plate)
	56				38		110		SM		Brownish gray with multi-color mottling SILTY SAND with gravel, dense (saprolite)
							115				Boring terminated at 112.5 feet * Elevations estimated from Site Plan transmitted by R. M. Towill Corporation on February 17, 2006.
							120				
							125				
							130				
							135				
							140				

BORING LOG 5014-00(A).GPJ GEOLABS.GDT 12/29/08

Date Started: August 21, 2006	Water Level: ∇ 9.1 ft. 8/23/06 1000 HRS	Plate A - 1.4
Date Completed: August 22, 2006		
Logged By: Y. Chiba	Drill Rig: CME-75	
Total Depth: 112.5 feet	Drilling Method: 4" Auger & PQ Coring	
Work Order: 5014-00(A)	Driving Energy: 140 lb. wt., 30 in. drop	



GEOLABS, INC.

Geotechnical Engineering

KAMEHAMEHA HIGHWAY (ROUTE 83)
KAIPAPAU STREAM BRIDGE REPLACEMENT
KOOLAULOA, OAHU, HAWAII

Log of Boring

2

Laboratory			Field				Depth (feet)	Sample	Graphic	USCS	Description
Other Tests	Moisture Content (%)	Dry Density (pcf)	Core Recovery (%)	RQD (%)	Penetration Resistance (blows/foot)	Pocket Pen. (tsf)					
											Approximate Ground Surface Elevation (feet MSL): 11.5 *
											3-inch ASPHALTIC CONCRETE 6-inch CONCRETE AIR
							5				
							10				WATER
			0				15		GM		Grayish dark brown SILTY GRAVEL with sand (basaltic), medium dense
	30		67		13		20				Gray CONCRETE , very hard (debris)
			10				25				Gray rounded GRAVEL AND COBBLES (BASALTIC) , very loose (recent alluvium)
	46				25		30		SP-SM		Brown SAND with silt and gravel (basaltic), medium dense (old alluvium)
			0				35		SM		Brown with multi-color mottling SILTY SAND with gravel, medium dense (old alluvium)
	51		57		28						

BORING LOG 5014-00(A).GPJ GEOLABS.GDT 12/29/08

Date Started: August 24, 2006	Water Level: ∇ 10 ft. 8/24/06 1230 HRS	Plate A - 2.1
Date Completed: August 25, 2006		
Logged By: Y. Chiba	Drill Rig: CME-75	
Total Depth: 112 feet	Drilling Method: 5" Auger & PQ Coring	
Work Order: 5014-00(A)	Driving Energy: 140 lb. wt., 30 in. drop	



GEOLABS, INC.

Geotechnical Engineering

KAMEHAMEHA HIGHWAY (ROUTE 83)
KAIPAPAU STREAM BRIDGE REPLACEMENT
KOOLAULOA, OAHU, HAWAII

Log of Boring

2

Laboratory			Field				Depth (feet)	Sample	Graphic	USCS	Description
Other Tests	Moisture Content (%)	Dry Density (pcf)	Core Recovery (%)	RQD (%)	Penetration Resistance (blows/foot)	Pocket Pen. (tsf)					
	52		100		33		35			SM	(Continued from previous plate)
	43		100		33		40				Brownish gray to grayish brown with multi-color mottling COBBLES AND GRAVEL (BASALTIC) with some boulders, slightly cemented, dense (conglomerate)
			75		10/0" Ref.		45				
			100		15/3" Ref.		50				
			100		8/0" Ref.		55				
	48		100		54		60				
	44		71		50		65				
							70				grades with clayey silt, medium dense

BORING LOG 5014-00(A).GPJ GEOLABS.GDT 12/29/08

Date Started: August 24, 2006	Water Level: ∇ 10 ft. 8/24/06 1230 HRS	Plate A - 2.2
Date Completed: August 25, 2006		
Logged By: Y. Chiba	Drill Rig: CME-75	
Total Depth: 112 feet	Drilling Method: 5" Auger & PQ Coring	
Work Order: 5014-00(A)	Driving Energy: 140 lb. wt., 30 in. drop	



GEOLABS, INC.

Geotechnical Engineering

KAMEHAMEHA HIGHWAY (ROUTE 83)
KAIPAPAU STREAM BRIDGE REPLACEMENT
KOOLAULOA, OAHU, HAWAII

Log of Boring

2

Laboratory			Field				Depth (feet)	Sample	Graphic	USCS	Description
Other Tests	Moisture Content (%)	Dry Density (pcf)	Core Recovery (%)	RQD (%)	Penetration Resistance (blows/foot)	Pocket Pen. (tsf)					
	62		71		27						(Continued from previous plate)
	54		100		38				SM		Brownish gray with multi-color mottling SILTY SAND , dense (saprolite)
	58		100	19	33						Greenish gray with white and black mottling BASALT , closely to severely fractured, highly weathered, medium hard to hard
	42		100	0	30/3" Ref.						grades to severely fractured
	46		71	14	53				SM		Brown with multi-color mottling SILTY SAND with some clay, dense (saprolite)
			63		8/3" Ref.						Grayish brown with multi-color mottling BASALT , closely to severely fractured, highly weathered, medium hard
									GM		Gray with multi-color mottling SILTY GRAVEL with sand, medium dense (saprolite)

BORING LOG 5014-00(A).GPJ GEOLABS.GDT 12/29/08

Date Started: August 24, 2006	Water Level: ∇ 10 ft. 8/24/06 1230 HRS	Plate A - 2.3
Date Completed: August 25, 2006		
Logged By: Y. Chiba	Drill Rig: CME-75	
Total Depth: 112 feet	Drilling Method: 5" Auger & PQ Coring	
Work Order: 5014-00(A)	Driving Energy: 140 lb. wt., 30 in. drop	



GEOLABS, INC.

Geotechnical Engineering

KAMEHAMEHA HIGHWAY (ROUTE 83)
KAIPAPAU STREAM BRIDGE REPLACEMENT
KOOLAULOA, OAHU, HAWAII

Log of Boring

2

Laboratory			Field				Depth (feet)	Sample	Graphic	USCS	Description
Other Tests	Moisture Content (%)	Dry Density (pcf)	Core Recovery (%)	RQD (%)	Penetration Resistance (blows/foot)	Pocket Pen. (tsf)					
			100	83	10/0" Ref.				GM	(Continued from previous plate)	
							110			Gray with dark gray and brown mottling vesicular to dense BASALT , closely to moderately fractured, moderately weathered, hard	
							115			Boring terminated at 112 feet	
							120				
							125				
							130				
							135				
							140				

Date Started: August 24, 2006

Date Completed: August 25, 2006

Logged By: Y. Chiba

Total Depth: 112 feet

Work Order: 5014-00(A)

Water Level: ∇ 10 ft. 8/24/06 1230 HRS

Drill Rig: CME-75

Drilling Method: 5" Auger & PQ Coring

Driving Energy: 140 lb. wt., 30 in. drop

Plate

A - 2.4



GEOLABS, INC.

Geotechnical Engineering

KAMEHAMEHA HIGHWAY (ROUTE 83)
KAIPAPAU STREAM BRIDGE REPLACEMENT
KOOLAULOA, OAHU, HAWAII

Log of Boring

3

Laboratory			Field				Depth (feet)	Sample	Graphic	USCS	Description
Other Tests	Moisture Content (%)	Dry Density (pcf)	Core Recovery (%)	RQD (%)	Penetration Resistance (blows/foot)	Pocket Pen. (tsf)					
											Approximate Ground Surface Elevation (feet MSL): 12 *
	51	68			21		0				9-inch ASPHALTIC CONCRETE
	13				16		5				Brown SANDY GRAVEL (CORALLINE) with silt, dense, dry (base course)
			0								Brown with multi-color mottling CLAYEY SILT with extremely weathered gravel (basaltic), medium stiff, moist (fill)
											Brown with multi-color mottling fine SANDY SILT with gravel (basaltic), medium stiff, damp (fill)
	29				2		10				Dark brown SILTY SAND with gravel, very loose (recent alluvium)
			0								grades with organic matter
	29				6						
			0								
	27				1		20				Dark brown poorly graded SAND with some well-rounded gravel in a silt matrix, very loose (recent alluvium)
			0								grades with well-rounded cobbles and boulders (basaltic)
			0		10/0" Ref.						
	56				17		35				Brown with multi-color mottling CLAYEY ROUNDED GRAVEL (BASALTIC) with sand, medium dense (old alluvium)
			0								

Date Started: August 22, 2006

Date Completed: August 24, 2006

Logged By: Y. Chiba

Total Depth: 112 feet

Work Order: 5014-00(A)

Water Level: ∇ 9.7 ft. 8/22/06 1310 HRS

Drill Rig: CME-75

Drilling Method: 5" Auger & PQ Coring

Driving Energy: 140 lb. wt., 30 in. drop

Plate

A - 3.1



GEOLABS, INC.

Geotechnical Engineering

KAMEHAMEHA HIGHWAY (ROUTE 83)
KAIPAPAU STREAM BRIDGE REPLACEMENT
KOOLAULOA, OAHU, HAWAII

Log of Boring

3

Laboratory			Field				Depth (feet)	Sample	Graphic	USCS	Description
Other Tests	Moisture Content (%)	Dry Density (pcf)	Core Recovery (%)	RQD (%)	Penetration Resistance (blows/foot)	Pocket Pen. (tsf)					
	56		0		11	1.0	35		CL	Brown with multi-color mottling SANDY CLAY with rounded gravel (basaltic), medium stiff (old alluvium)	
	55		0		10	1.0	40				
	42		0		39		45		GW-GM	Brown with multi-color mottling rounded GRAVEL (BASALTIC) with sand and silt in a clay matrix, slightly cemented, dense (old alluvium)	
	26		0		36		50				
	39		29		36		55				
			100		15/3" Ref.		60			Greenish gray with multi-color mottling slightly cemented COBBLES AND BOULDERS (BASALTIC) with gravel in a clay matrix, dense (old alluvium)	
	28		71		26		65			grades to medium dense, breaks down to silty sand	
							70				

(Continued from previous plate)

Description

BORING LOG 5014-00(A).GPJ GEOLABS.GDT 12/29/08

Date Started: August 22, 2006	Water Level: ∇ 9.7 ft. 8/22/06 1310 HRS	Plate A - 3.2
Date Completed: August 24, 2006		
Logged By: Y. Chiba	Drill Rig: CME-75	
Total Depth: 112 feet	Drilling Method: 5" Auger & PQ Coring	
Work Order: 5014-00(A)	Driving Energy: 140 lb. wt., 30 in. drop	



GEOLABS, INC.

Geotechnical Engineering

KAMEHAMEHA HIGHWAY (ROUTE 83)
KAIPAPAU STREAM BRIDGE REPLACEMENT
KOOLAULOA, OAHU, HAWAII

Log of Boring

3

Laboratory			Field				Depth (feet)	Sample	Graphic	USCS	Description
Other Tests	Moisture Content (%)	Dry Density (pcf)	Core Recovery (%)	RQD (%)	Penetration Resistance (blows/foot)	Pocket Pen. (tsf)					
	68		100		23		75				grades to brown with multi-color mottling
	62		100		26		80				Brown with multi-color mottling SANDY CLAY , medium stiff (old alluvium) Gray with multi-color mottling densely cemented COBBLES AND GRAVEL (BASALTIC) , dense (weathered conglomerate)
			75		10/0" Ref.		85				grades to brownish gray with multi-color mottling, medium dense
	41		100		25/3" Ref.		90				grades to brownish gray with multi-color mottling, medium dense
	55		84		15/3" Ref.		95				grades to moderately cemented, dense
	57		100		10/0" Ref.		100				grades to gray with multi-color mottling, densely cemented
			100		15/1" Ref.		105				grades to reddish brown with black mottling

(Continued from previous plate)

BORING LOG 5014-00(A).GPJ GEOLABS.GDT 12/29/08

Date Started: August 22, 2006	Water Level: ∇ 9.7 ft. 8/22/06 1310 HRS	Plate A - 3.3
Date Completed: August 24, 2006		
Logged By: Y. Chiba	Drill Rig: CME-75	
Total Depth: 112 feet	Drilling Method: 5" Auger & PQ Coring	
Work Order: 5014-00(A)	Driving Energy: 140 lb. wt., 30 in. drop	



GEOLABS, INC.

Geotechnical Engineering

KAMEHAMEHA HIGHWAY (ROUTE 83)
KAIPAPAU STREAM BRIDGE REPLACEMENT
KOOLAULOA, OAHU, HAWAII

Log of Boring

3

Laboratory			Field				Depth (feet)	Sample	Graphic	USCS	Description
Other Tests	Moisture Content (%)	Dry Density (pcf)	Core Recovery (%)	RQD (%)	Penetration Resistance (blows/foot)	Pocket Pen. (tsf)					
			100		10/0" Ref.						(Continued from previous plate)
							110				grades to very dense
							115				Boring terminated at 112 feet
							120				
							125				
							130				
							135				
							140				

Date Started: August 22, 2006

Date Completed: August 24, 2006

Logged By: Y. Chiba

Total Depth: 112 feet

Work Order: 5014-00(A)

Water Level: ∇ 9.7 ft. 8/22/06 1310 HRS

Drill Rig: CME-75

Drilling Method: 5" Auger & PQ Coring

Driving Energy: 140 lb. wt., 30 in. drop

Plate

A - 3.4



GEOLABS, INC.

Geotechnical Engineering

KAMEHAMEHA HIGHWAY (ROUTE 83)
KAIPAPAU STREAM BRIDGE REPLACEMENT
KOOLAULOA, OAHU, HAWAII

Log of Boring

4

Laboratory			Field				Depth (feet)	Sample	Graphic	USCS	Description
Other Tests	Moisture Content (%)	Dry Density (pcf)	Core Recovery (%)	RQD (%)	Penetration Resistance (blows/foot)	Pocket Pen. (tsf)					
											Approximate Ground Surface Elevation (feet MSL): 9 *
	20	83			33		0		SW		6-inch ASPHALTIC CONCRETE
	7				18		1		SP		Dark brown GRAVELLY SAND (CORALLINE) AND SOME CLAY , medium dense, damp
	27				6		5				Dark brown with tan mottling poorly graded fine SAND , medium dense, damp
							5			SM	Dark brown with tan mottling SILTY SAND , loose
	28				2		10			GW	Dark brown with tan mottling rounded GRAVEL with sand (coralline and basaltic), very loose
	17				5		15			SM	Tannish gray SILTY SAND with some gravel (coralline), very loose
							16.5				Boring terminated at 16.5 feet

Date Started: August 29, 2006

Date Completed: August 29, 2006

Logged By: Y. Chiba

Total Depth: 16.5 feet

Work Order: 5014-00(A)

Water Level: ∇ 5.9 ft. 8/29/06 0953 HRS

Drill Rig: CME-75

Drilling Method: 4" Auger

Driving Energy: 140 lb. wt., 30 in. drop

Plate

A - 4



GEOLABS, INC.

Geotechnical Engineering

KAMEHAMEHA HIGHWAY (ROUTE 83)
KAIPAPAU STREAM BRIDGE REPLACEMENT
KOOLAULO, OAHU, HAWAII

Log of Boring

5

Laboratory			Field				Depth (feet)	Sample	Graphic	USCS	Approximate Ground Surface Elevation (feet MSL): 10 *
Other Tests	Moisture Content (%)	Dry Density (pcf)	Core Recovery (%)	RQD (%)	Penetration Resistance (blows/foot)	Pocket Pen. (tsf)					Description
LL=68 PI=41 LL=64 PI=39	37	75			31	1.0	0		GW	5-inch ASPHALTIC CONCRETE	
							1.0		CH	Brownish gray SANDY GRAVEL (BASALTIC) with silt, medium dense, dry	
LL=54 PI=40	33				9					Dark brown with orange mottling CLAY with some gravel (basaltic), medium stiff, damp grades to medium stiff to stiff at 3.3 feet	
	35	78			6		5		CH	Brownish tan fine CLAY with sand, soft to medium stiff, moist	
	69				6		10		ML	Grayish dark brown fine SANDY SILT , very loose	
	32				15		15		SP	Brownish dark gray with light gray mottling poorly graded fine SAND with silt, medium dense	
Boring terminated at 16.5 feet											

Date Started: August 28, 2006

Date Completed: August 28, 2006

Logged By: Y. Chiba

Total Depth: 16.5 feet

Work Order: 5014-00(A)

Water Level: ∇ 8.4 ft. 8/28/06 1348 HRS

Drill Rig: CME-75

Drilling Method: 4" Auger

Driving Energy: 140 lb. wt., 30 in. drop

Plate

A - 5



GEOLABS, INC.

Geotechnical Engineering

KAMEHAMEHA HIGHWAY (ROUTE 83)
KAIPAPAU STREAM BRIDGE REPLACEMENT
KOOLAULOA, OAHU, HAWAII

Log of Boring

6

Laboratory			Field				Depth (feet)	Sample	Graphic	USCS	Approximate Ground Surface Elevation (feet MSL): 13 *
Other Tests	Moisture Content (%)	Dry Density (pcf)	Core Recovery (%)	RQD (%)	Penetration Resistance (blows/foot)	Pocket Pen. (tsf)					Description
LL=56 PI=31	31	86			40	1.5	0-1.5	[Diagonal Hatching]	GW CH	6-inch ASPHALTIC CONCRETE	
										Tan SANDY GRAVEL (CORALLINE) , dense, dry	
LL=56 PI=27	23				7	1.0	1.5-5.0	[Diagonal Hatching]	CH	Dark brown CLAY with some rounded gravel (basaltic), stiff, damp	
										Dark brown SILTY CLAY with sand, medium stiff to stiff, damp	
LL=55 PI=25	29	84			17	1.5	5.0-15.0	[Diagonal Hatching]	MH	Dark brown SILT with clay and sand, stiff, damp	
										grades with cobbles and boulders (basaltic)	
					15/0" Ref.					Dark brown with multi-color mottling rounded GRAVEL AND COBBLES (BASALTIC) with silt, dense, damp	
					10/0" Ref.					Boring terminated at 15 feet	

BORING LOG 5014-00(A).GPJ GEOLABS.GDT 12/29/08

Date Started: August 28, 2006	Water Level: ∇ Not Encountered	Plate
Date Completed: August 28, 2006		
Logged By: Y. Chiba	Drill Rig: CME-75	A - 6
Total Depth: 15 feet	Drilling Method: 4" Auger	
Work Order: 5014-00(A)	Driving Energy: 140 lb. wt., 30 in. drop	



GEOLABS, INC.

Geotechnical Engineering

KAMEHAMEHA HIGHWAY (ROUTE 83)
KAIPAPAU STREAM BRIDGE REPLACEMENT
KOOLAULOA, OAHU, HAWAII

Log of Boring

7

Laboratory			Field				Depth (feet)	Sample	Graphic	USCS	Description
Other Tests	Moisture Content (%)	Dry Density (pcf)	Core Recovery (%)	RQD (%)	Penetration Resistance (blows/foot)	Pocket Pen. (tsf)					
											Approximate Ground Surface Elevation (feet MSL): 15.5 *
LL=95 PI=64	26	84			28	1.0			GW CH		6-inch ASPHALTIC CONCRETE
	17				10						Brownish gray SANDY GRAVEL (BASALTIC) , dense, dry
						1.0			SM MH		Dark brown with white and black mottling CLAY with some gravel (coralline), medium stiff to stiff, damp
	30	85			18		5		SM		Light brownish tan SILTY SAND (CORALLINE) , loose to medium dense, damp
											Brownish tan CLAYEY SILT , medium stiff to stiff, damp
	14				16		10		GP- GM		Dark brown with multi-color mottling SILTY SAND with some well-rounded gravel, medium dense, damp
					10/0" Ref.						Dark brown GRAVEL with silt and sand, medium dense, damp grades with cobbles and boulders (basaltic) at 11.7 feet
											Boring terminated at 13 feet
							15				
							20				
							25				
							30				
							35				

Date Started: August 28, 2006

Date Completed: August 28, 2006

Logged By: Y. Chiba

Total Depth: 13 feet

Work Order: 5014-00(A)

Water Level: ∇ Not Encountered

Drill Rig: CME-75

Drilling Method: 4" Auger

Driving Energy: 140 lb. wt., 30 in. drop

Plate

A - 7

APPENDIX B

APPENDIX B

Laboratory Tests

Moisture Content (ASTM D 2216) and Unit Weight determinations (ASTM D 2937) were performed on selected soil samples as an aid in the classification and evaluation of soil properties. The test results are presented on the Logs of Borings at the appropriate sample depths.

Seven Atterberg Limits tests (ASTM D 4318) were performed on selected soil samples to evaluate the liquid and plastic limits and to aid in soil classification. Test results are summarized on the Logs of Borings at the appropriate sample depth. Graphic presentation of the test results is provided on Plate B-1.

Fourteen Sieve Analysis tests were performed on selected samples of the soils to evaluate the gradation characteristics and to aid in soil classification. The tests were performed in accordance with ASTM C 117 and C 136. Graphic presentation of the grain size distribution is provided on Plate B-2 through B-4.

Two California Bearing Ratio (CBR) tests (ASTM D 1883) were performed on bulk samples of the near-surface soils to evaluate the strength characteristics for pavement subgrade support. CBR test results are presented on Plate B-5 and B-6.

Two laboratory Resistance (R) Value tests (ASTM D 2844) were performed by Signet Testing Labs on two selected bulk samples of the near-surface soils to evaluate the pavement support characteristics of the soils. The test results are presented on Plates B-7 and B-8.

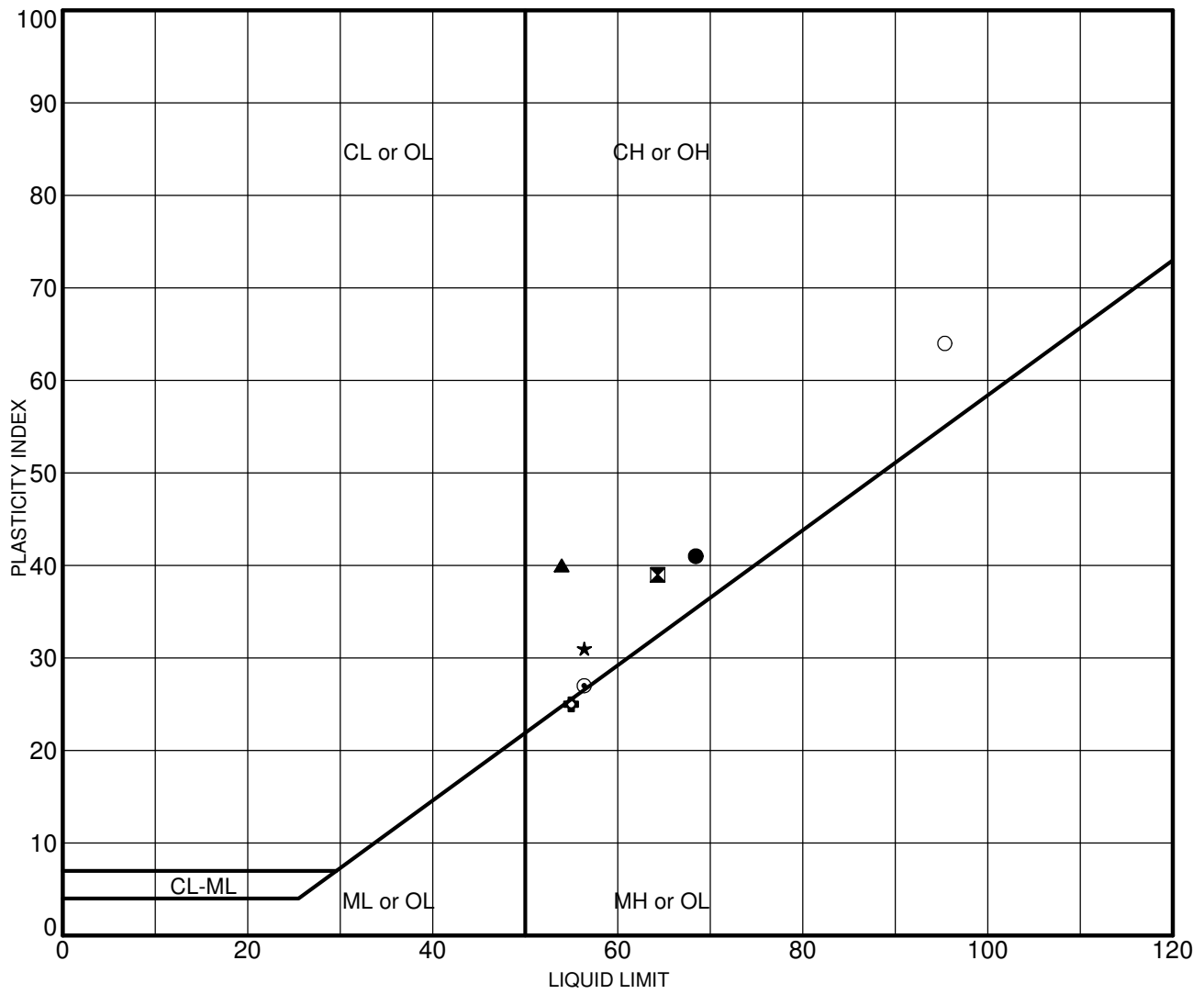

Sample	Depth (ft)	LL	PL	PI	Description	
●	B-5	1.0-2.5	68	27	41	Brown clay (CH)
⊠	B-5	2.5-4.0	64	25	39	Brown clay (CH)
▲	B-5	5.0-6.5	54	14	40	Brown clay (CH)
★	B-6	1.5-3.0	56	25	31	Brown clay (CH)
⊙	B-6	3.0-4.5	56	29	27	Brown silty clay (CH)
⊕	B-6	5.0-6.5	55	30	25	Brown silt (MH)
○	B-7	1.0-2.5	95	31	64	Brown clay (CH)

G. ATTERBERG 5014-00(A).GPI.GEOLABS.GDT 12/29/08



GEOLABS, INC.
 GEOTECHNICAL ENGINEERING
 W.O. 5014-00(A)

ATTERBERG LIMITS TEST RESULTS - ASTM D 4318

KAMEHAMEHA HIGHWAY (ROUTE 83)
 KAIPAPAU STREAM BRIDGE REPLACEMENT
 KOOLAULOA, OAHU, HAWAII

Plate
B - 1

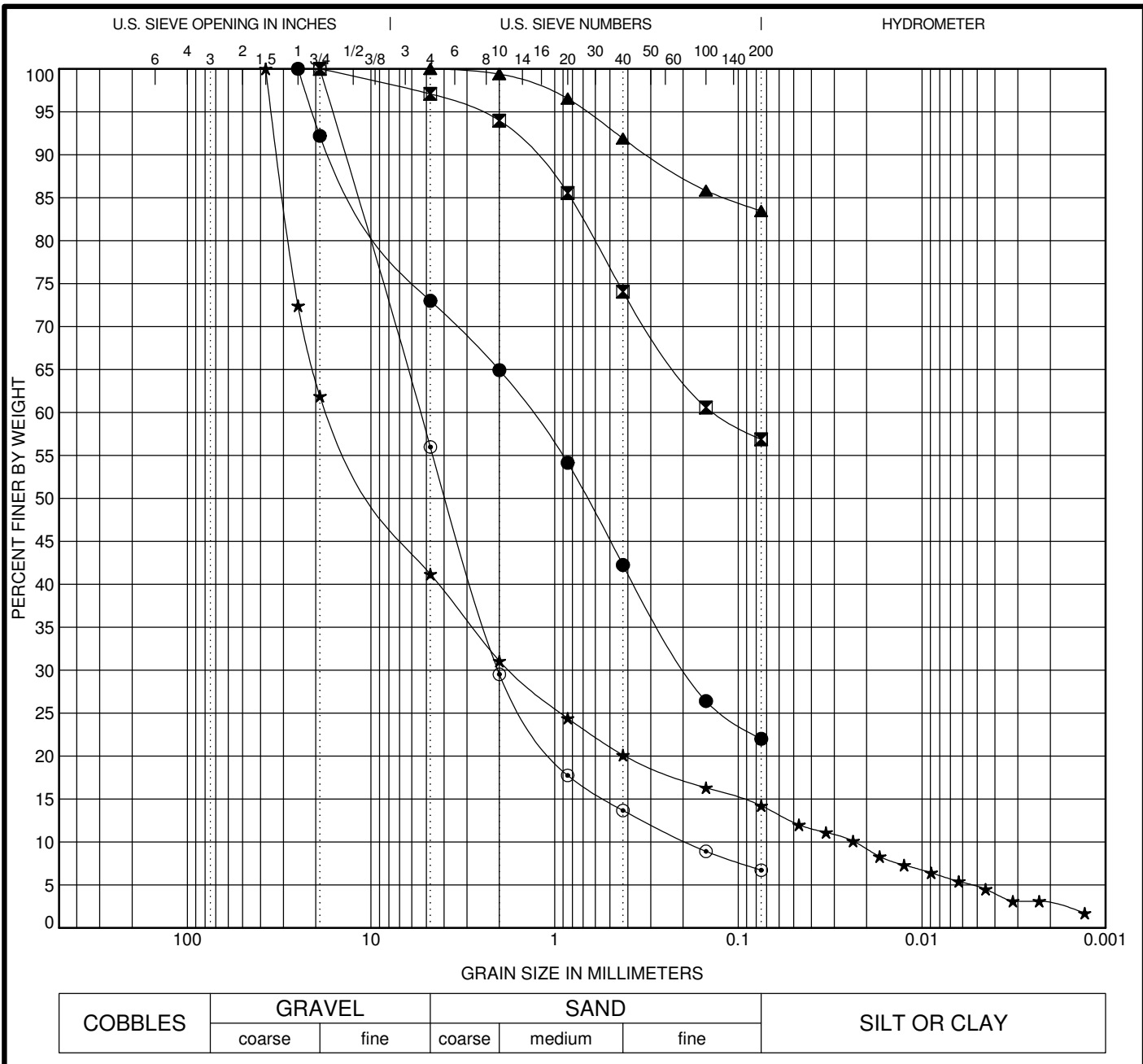

COBBLES	GRAVEL		SAND			SILT OR CLAY
	coarse	fine	coarse	medium	fine	

Sample	Depth (ft)	Description	LL	PL	PI	Cc	Cu
●	B-1	10.0-11.5	Brown silty sand (SM) with gravel				
☒	B-1	46.0-47.5	Brown sandy silt (ML)				
▲	B-1	76.0-77.5	Brown silt with sand (ML)				
★	B-2	17.0-18.5	Dark gray silty gravel (GM) with sand			7.8	719.4
◎	B-2	27.0-28.5	Brown sand (SP-SM) with silt and gravel			4.0	28.3

Sample	Depth (ft)	D100 (mm)	D60 (mm)	D30 (mm)	D10 (mm)	%Gravel	%Sand	%Fine
●	B-1	10.0-11.5	25	1.353	0.19	27.0	51.0	22.0
☒	B-1	46.0-47.5	19	0.135		2.9	40.2	56.9
▲	B-1	76.0-77.5	4.75			0.0	16.5	83.5
★	B-2	17.0-18.5	37.5	16.739	1.746	0.023	58.8	27.0
◎	B-2	27.0-28.5	19	5.392	2.032	0.191	44.0	49.3

G. GRAIN SIZE 5014-00(A).GPJ GEOLABS.GDT_12/29/08



GEOLABS, INC.
 GEOTECHNICAL ENGINEERING
 W.O. 5014-00(A)

GRAIN SIZE DISTRIBUTION - ASTM C 117 & C 136

KAMEHAMEHA HIGHWAY (ROUTE 83)
 KAIPAPAU STREAM BRIDGE REPLACEMENT
 KOOLAULOA, OAHU, HAWAII

Plate
B - 2

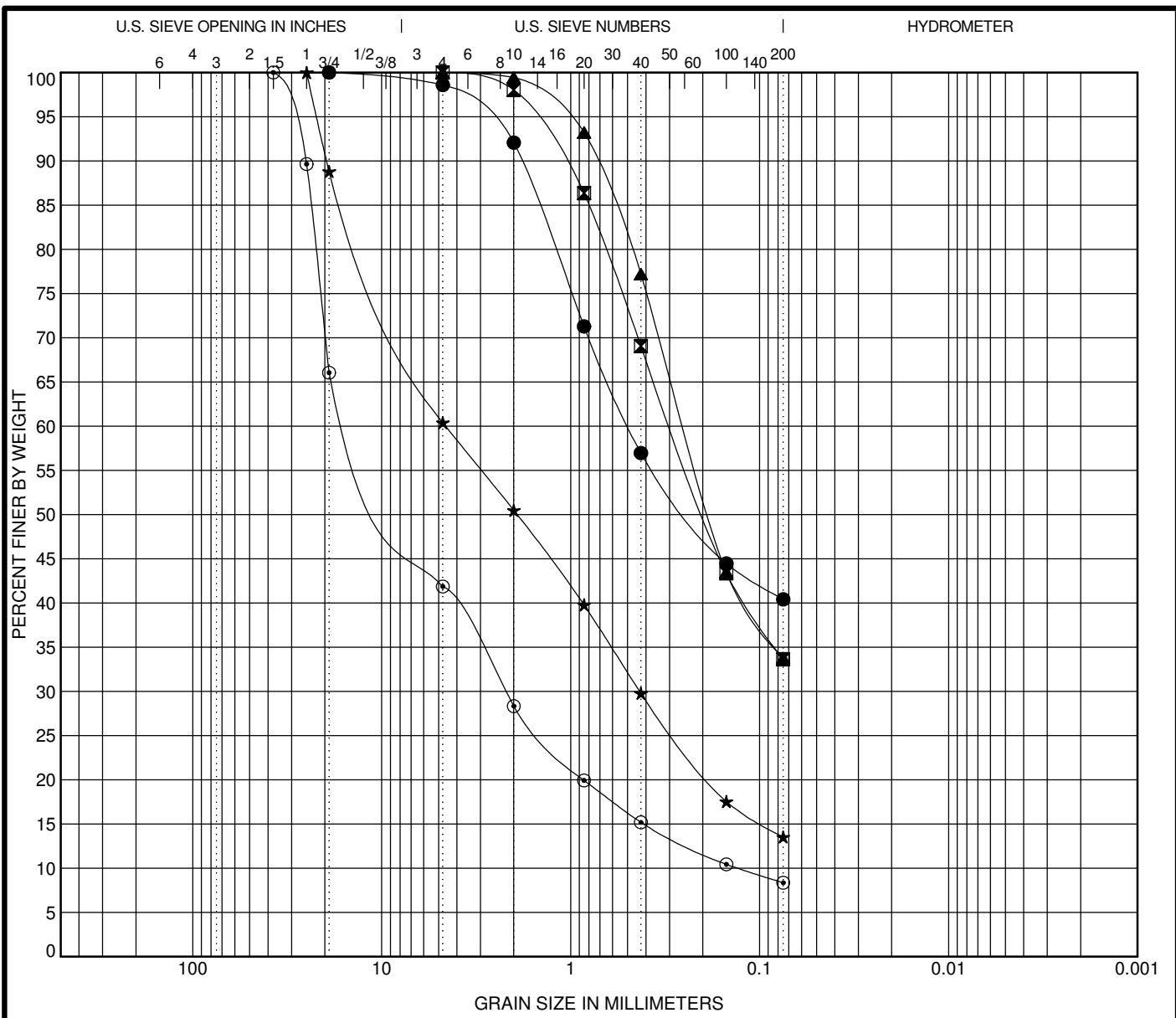

COBBLES	GRAVEL		SAND			SILT OR CLAY
	coarse	fine	coarse	medium	fine	

Sample	Depth (ft)	Description	LL	PL	PI	Cc	Cu
●	B-2	37.0-38.5					
■	B-2	77.0-78.5					
▲	B-2	97.0-98.5					
★	B-3	12.0-13.5					
⊙	B-3	52.0-53.5				2.8	103.4

Sample	Depth (ft)	D100 (mm)	D60 (mm)	D30 (mm)	D10 (mm)	%Gravel	%Sand	%Fine
●	B-2	37.0-38.5	19	0.493		1.4	58.2	40.4
■	B-2	77.0-78.5	4.75	0.295		0.0	66.4	33.6
▲	B-2	97.0-98.5	4.75	0.25		0.0	66.2	33.8
★	B-3	12.0-13.5	25	4.59	0.432	39.6	46.9	13.5
⊙	B-3	52.0-53.5	37.5	13.44	2.226	0.13	58.1	33.5

G. GRAIN SIZE 5014-00(A).GPJ GEOLABS.GDT_12/29/08

	GEOLABS, INC. GEOTECHNICAL ENGINEERING	GRAIN SIZE DISTRIBUTION - ASTM C 117 & C 136	
	W.O. 5014-00(A)	KAMEHAMEHA HIGHWAY (ROUTE 83) KAIPAPAU STREAM BRIDGE REPLACEMENT KOOLAULOA, OAHU, HAWAII	
			Plate B - 3

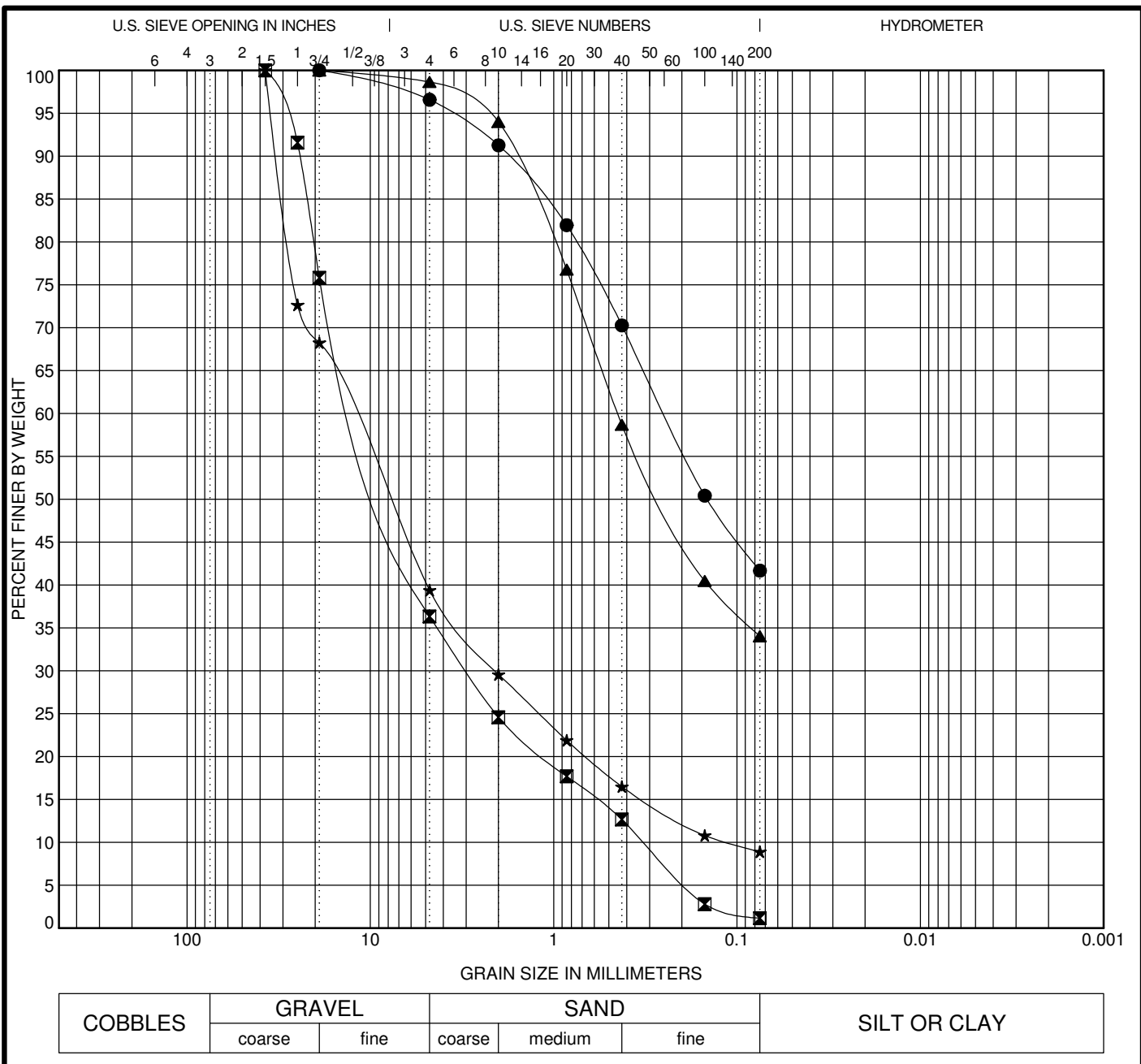

COBBLES	GRAVEL		SAND			SILT OR CLAY
	coarse	fine	coarse	medium	fine	

Sample	Depth (ft)	Description	LL	PL	PI	Cc	Cu
● B-3	72.0-73.5	Brown silty sand (SM)					
☒ B-4	10.0-11.5	Brown gravel (GW) with sand				2.5	33.9
▲ B-7	5.0-6.5	Brown silty sand (SM)					
★ B-7	10.0-11.5	Brown gravel (GP-GM) with silt and sand				3.0	114.0

Sample	Depth (ft)	D100 (mm)	D60 (mm)	D30 (mm)	D10 (mm)	%Gravel	%Sand	%Fine
● B-3	72.0-73.5	19	0.248			3.4	54.9	41.7
☒ B-4	10.0-11.5	37.5	10.906	2.98	0.321	63.7	35.2	1.1
▲ B-7	5.0-6.5	19	0.447			1.4	64.6	34.0
★ B-7	10.0-11.5	37.5	12.782	2.079	0.112	60.6	30.5	8.9

G. GRAIN SIZE 5014-00(A).GPJ GEOLABS.GDT_12/29/08

	GEOLABS, INC. GEOTECHNICAL ENGINEERING	GRAIN SIZE DISTRIBUTION - ASTM C 117 & C 136	
	W.O. 5014-00(A)	KAMEHAMEHA HIGHWAY (ROUTE 83) KAIPAPAU STREAM BRIDGE REPLACEMENT KOOLAULOA, OAHU, HAWAII	Plate B - 4

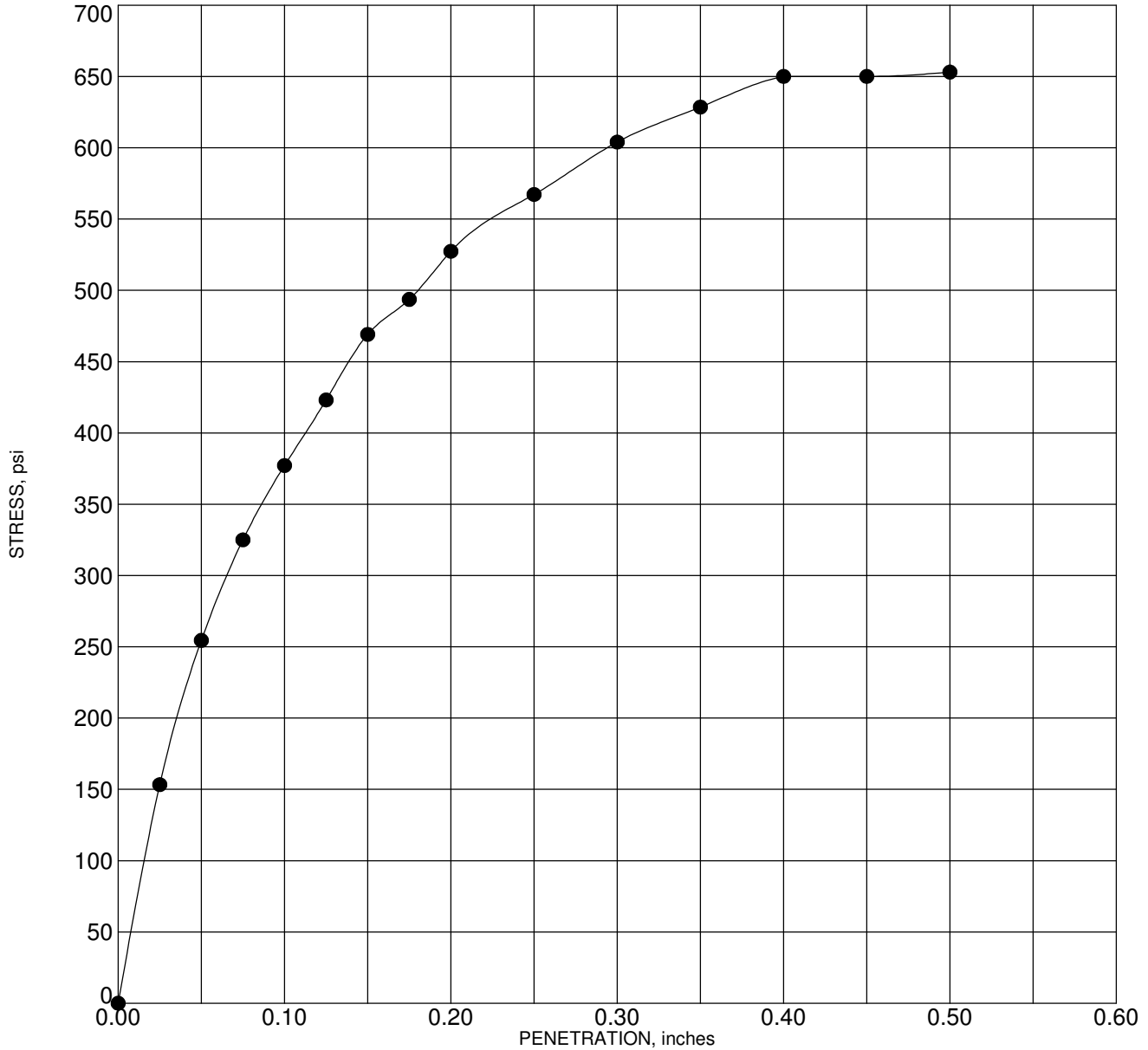

Corr. CBR @ 0.1"	37.7
Swell (%)	0.04

Sample: Bulk-1
 Depth: 1.5 - 3.5 feet
 Description: Gray silty sand

Molding Dry Density (pcf)	124.6	Hammer Wt. (lbs)	10
Molding Moisture (%)	10.3	Hammer Drop (inches)	18
Days Soaked	3	No. of Blows	56
Aggregate	3/4 inch minus	No. of Layers	5



GEOLABS, INC.
 GEOTECHNICAL ENGINEERING
 W.O. 5014-00(A)

CALIFORNIA BEARING RATIO - ASTM D 1883

KAMEHAMEHA HIGHWAY (ROUTE 83)
 KAIPAPAU STREAM BRIDGE REPLACEMENT
 KOOLAULOA, OAHU, HAWAII

Plate
B - 5

G. CBR. 5014-00(A).GPJ. GEOLABS.GDT. 12/29/08

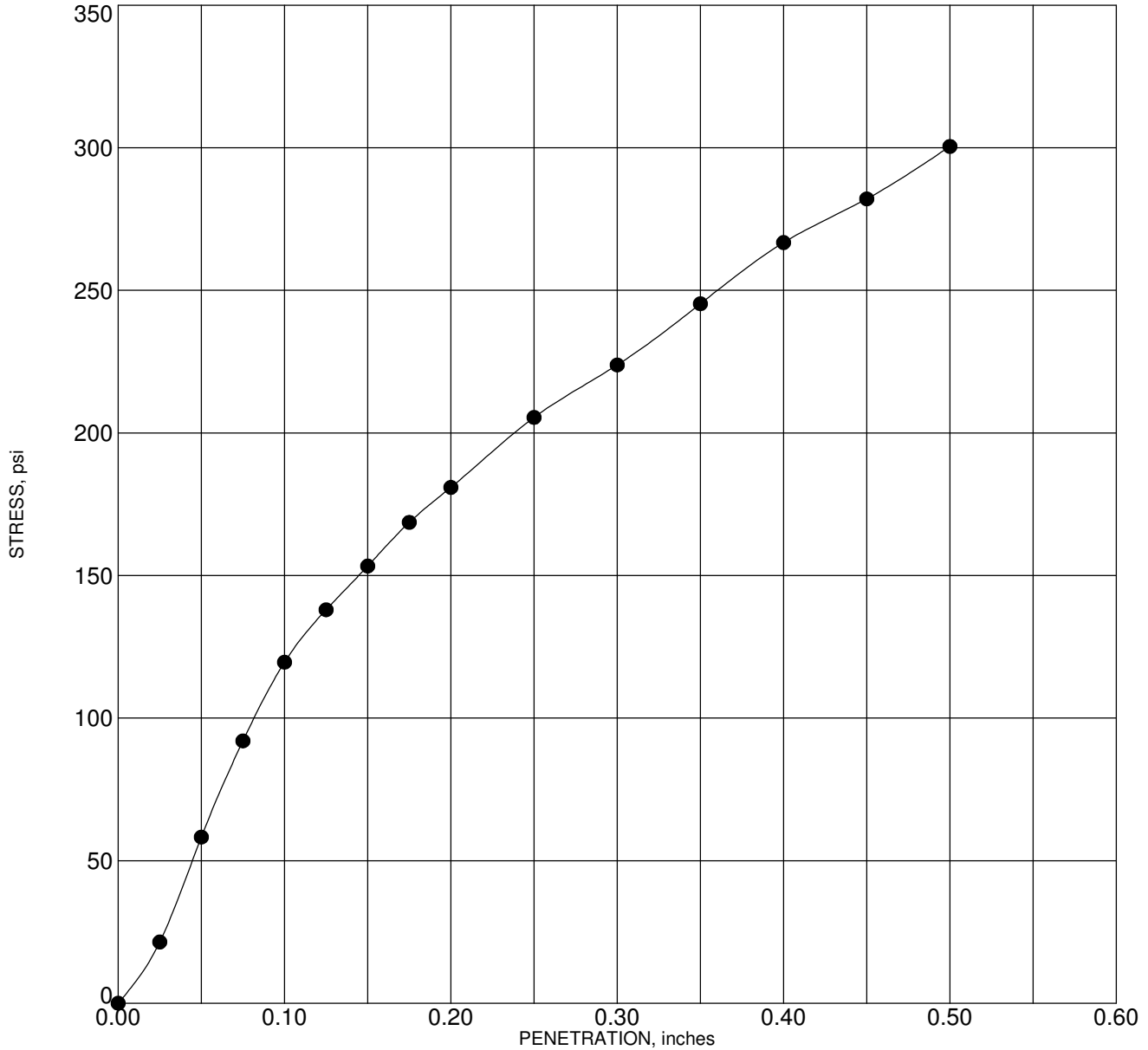

Corr. CBR @ 0.1"	12.9
Swell (%)	1.87

Sample: Bulk-2
 Depth: 1.5 - 3.5 feet
 Description: Dark gray silty clay with sand and gravel (coralline)

Molding Dry Density (pcf)	101.6	Hammer Wt. (lbs)	10
Molding Moisture (%)	24.6	Hammer Drop (inches)	18
Days Soaked	4	No. of Blows	56
Aggregate	3/4 inch minus	No. of Layers	5



GEOLABS, INC.
 GEOTECHNICAL ENGINEERING
 W.O. 5014-00(A)

CALIFORNIA BEARING RATIO - ASTM D 1883

KAMEHAMEHA HIGHWAY (ROUTE 83)
 KAIPAPAU STREAM BRIDGE REPLACEMENT
 KOOLAULOA, OAHU, HAWAII

Plate
B - 6

G. CBR. 5014-00(A).GPJ. GEOLABS.GDT. 12/29/08

R-VALUE TEST REPORT

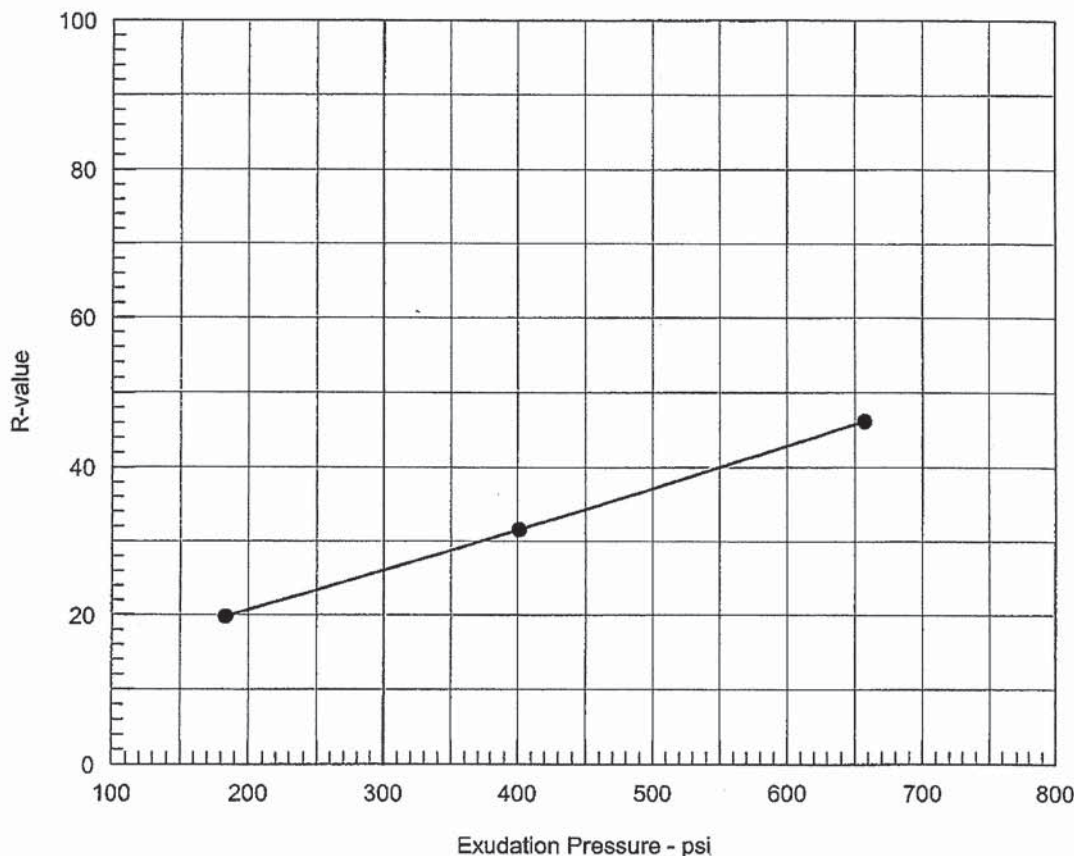

Resistance R-Value and Expansion Pressure - ASTM D 2844

No.	Compact. Pressure psi	Density pcf	Moist. %	Expansion Pressure psi	Horizontal Press. psi @ 160 psi	Sample Height in.	Exud. Pressure psi	R Value	R Value Corr.
1	230	89.6	30.7	3.33	72	2.51	657	46	46
2	60	81.3	37.8	0.55	120	2.65	183	18	20
3	140	84.7	35.1	1.03	96	2.54	401	32	32

Test Results	Material Description
R-value at 300 psi exudation pressure = 26	Reddish brown silt with clay and organics, Bulk #1, 0-2', sample received 11/7/2007
Project No.: 0007653 Project: Location: Kamehameha Hwy (Rte 83), Kaipapau Stream Br. Repl., #5014-00 Sample Number: L11647-1 Date: 7/2/2008	Tested by: Dan N Checked by: LKL Remarks: Bulk #1
R-VALUE TEST REPORT SIGNET TESTING LABS, INC.	Figure _____

R-VALUE TEST REPORT

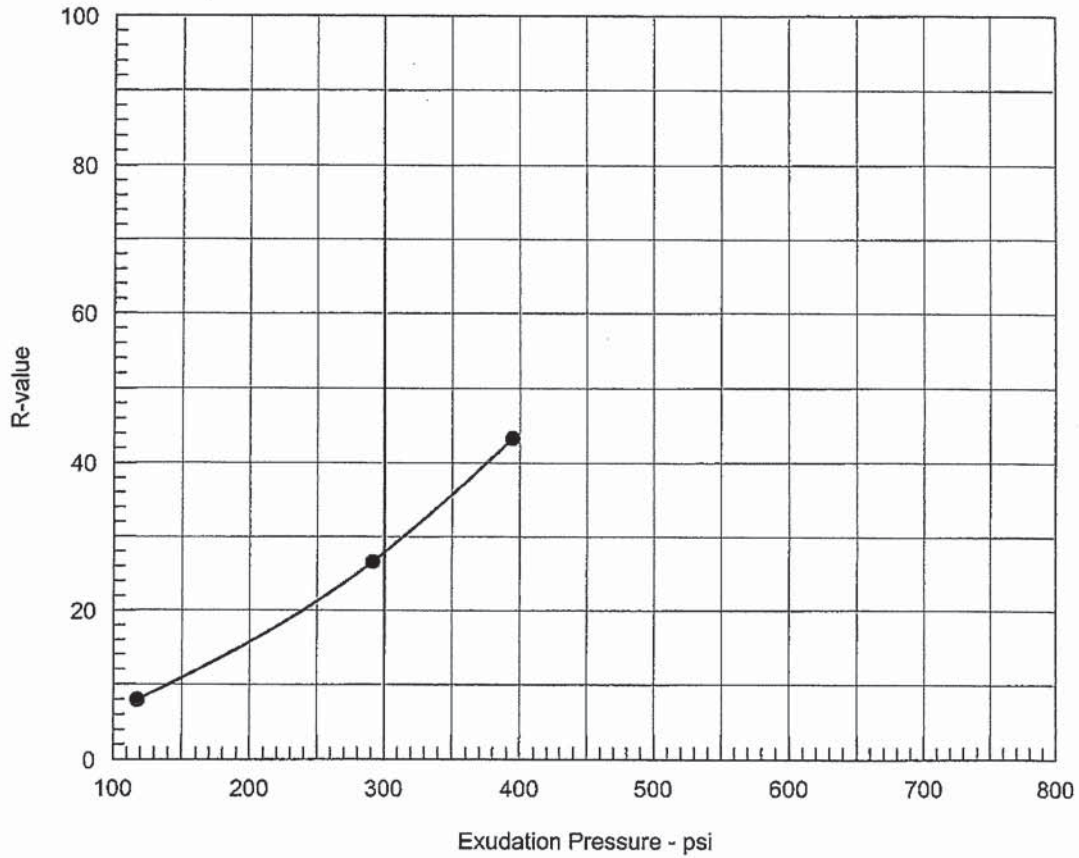

Resistance R-Value and Expansion Pressure - ASTM D 2844

No.	Compact. Pressure psi	Density pcf	Moist. %	Expansion Pressure psi	Horizontal Press. psi @ 160 psi	Sample Height in.	Exud. Pressure psi	R Value	R Value Corr.
1	45	95.3	26.3	0.00	139	2.60	118	8	8
2	175	99.9	22.8	0.67	102	2.59	291	25	27
3	230	103.8	21.1	0.76	75	2.57	395	42	43

Test Results	Material Description
R-value at 300 psi exudation pressure = 28	Dark brown sandy silt with organics, Bulk #2, 0-2', sample received 11/7/2007
Project No.: 0007653 Project: Location: Kamehameha Hwy (Rte 83), Kaipapau Stream Br. Repl., #5014-00 Sample Number: L11647-2 Date: 7/2/2008	Tested by: Dan N Checked by: LKL Remarks: Bulk #2
R-VALUE TEST REPORT SIGNET TESTING LABS, INC.	Figure _____

APPENDIX C

APPENDIX C

Field Permeability Tests

The permeability of the in-situ materials at the bridge abutment locations was evaluated by performing both falling and constant head tests in Boring Nos 1 and 2. The falling and constant head tests were performed at various depths below the existing ground surface. The approximate boring locations are shown on the Site Plan, Plate 2. Casing was used for drilling and testing.

During the falling head testing, the borehole was carefully filled with water to the top. The time intervals and water drops were then recorded to provide data upon which to base calculation of the permeability value of the subsoils. Falling head permeability test results are presented on Plates C-1, C-3, C-5 and C-7.

The constant head test was performed by pumping water into the borehole until the water surface has stabilized and remained at equilibrium for a sufficient period of time. The water height and the rate of pumping were then measured to provide data upon which to base calculation of the subsoil permeability. Constant head permeability test results are presented on Plates C-2, C-4, C-6 and C-8.

GEOTECHNICAL ENGINEERING EXPLORATION
KAMEHAMEHA HIGHWAY (ROUTE 83)
KAIPAPAU STREAM BRIDGE REPLACEMENT
KOOLAULOA, OAHU, HAWAII

Percolation Test Calculation Sheet (Constant Head Method: Well point-filter in uniform soil)

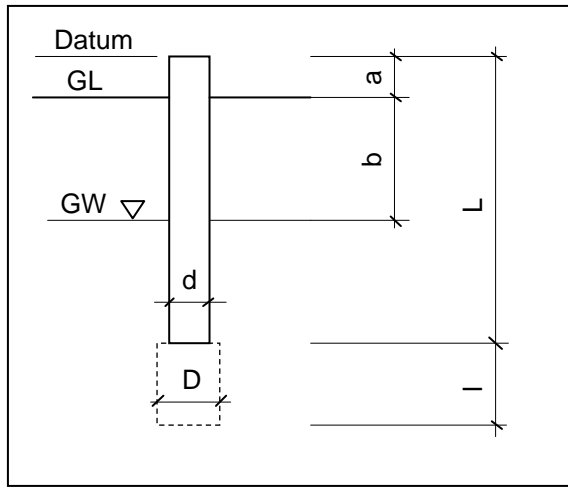

Boring:	B-1 @ 16.5 feet
GW table, b (from ground):	7.15 feet
Datum, a (above ground):	3 feet
Depth of casing:	14 feet
Length, L (from datum):	17 feet
Open hole Length, l:	2.5 feet
Diameter of open hole (D):	4.5 inches
Diameter of casing (d):	4 inches
Constant flow rate, Q:	7.50 gpm
Constant water level (FD):	4.95 feet

Constant flow rate, Q = 7.50 gpm
 = 1.00 feet³/min
 Piezometer head, H_c = 5.20 feet
 Factor of m ($\sqrt{\frac{k_h}{k_v}}$) = 1.00

Permeability, k

$$k = \frac{q \times \ln \left[\frac{ml}{D} + \sqrt{1 + \left(\frac{ml}{D} \right)^2} \right]}{2 \times \pi \times l \times H_c} = \begin{array}{|l} \hline 0.032 \text{ feet/min} \\ \hline 0.016 \text{ cm/s} \\ \hline \end{array}$$

GEOTECHNICAL ENGINEERING EXPLORATION
KAMEHAMEHA HIGHWAY (ROUTE 83)
KAIPAPAU STREAM BRIDGE REPLACEMENT
KOOLAULOA, OAHU, HAWAII

Percolation Test Calculation Sheet (Falling Head Method: Well point-filter in uniform soil)

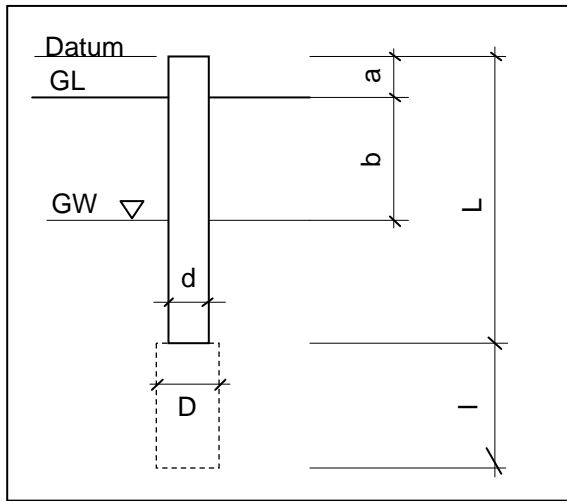

Boring: **B-1 @ 16.5 feet**
 GW table, b (from ground): **7.15** feet
 Datum, a (above ground): **3** feet
 Depth of casing: **14** feet
 Length, L (from datum): **17** feet
 Open hole Length, l: **2.5** feet
 Diameter of open hole (D): **4.5** inches
 Diameter of casing (d): **4** inches

Factor of m ($\sqrt{\frac{k_h}{k_v}}$) = 1.00

Time (min)	Depth of water (from datum) (feet)	Piezometer Head, H _c (feet)
0.0	5.0	5.2
1.0	7.8	2.4
2.0	8.8	1.35
3.0	9.2	0.95
4.0	9.5	0.7
5.0	9.6	0.6
6.0	9.6	0.6

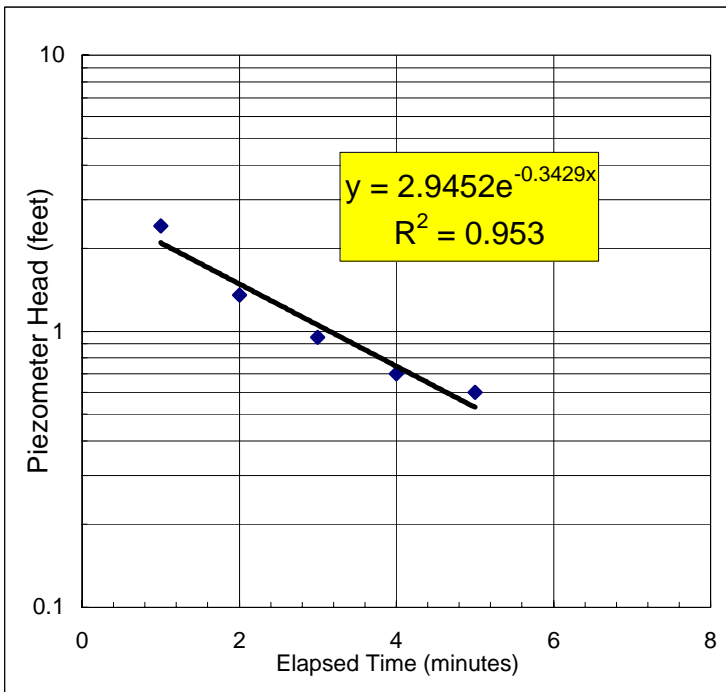

Constant factor of the trendline $y = \lambda e^{cx}$
 $\lambda = 2.9452$
 $c = -0.3429$
 $\frac{\ln(H_{1c} / H_{2c})}{(t_2 - t_1)} = 0.34$

Permeability, k, When $2ml/D \leq 4$,

$$k = \frac{d^2 \times \ln\left[\frac{ml}{D} + \sqrt{1 + \left(\frac{ml}{D}\right)^2}\right]}{8 \times l \times (t_2 - t_1)} \times \ln\left(\frac{H_{1c}}{H_{2c}}\right) = \frac{4.9E-03 \text{ feet/min}}{2.5E-03 \text{ cm/s}}$$

Permeability, k, When $2ml/D > 4$,

$$k = \frac{d^2 \times \ln\left(\frac{2ml}{D}\right)}{8 \times l \times (t_2 - t_1)} \times \ln\left(\frac{H_{1c}}{H_{2c}}\right) = \frac{4.9E-03 \text{ feet/min}}{2.5E-03 \text{ cm/s}}$$

GEOTECHNICAL ENGINEERING EXPLORATION
KAMEHAMEHA HIGHWAY (ROUTE 83)
KAIPAPAU STREAM BRIDGE REPLACEMENT
KOOLAULOA, OAHU, HAWAII

Percolation Test Calculation Sheet (Constant Head Method: Well point-filter in uniform soil)

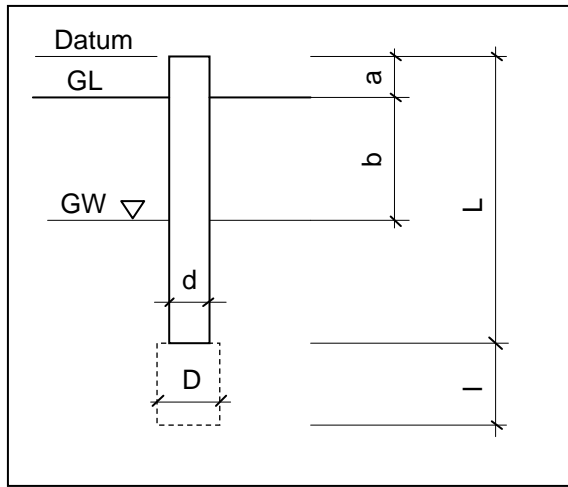

Boring:	B-1 @ 21.5 feet
GW table, b (from ground):	7.5 feet
Datum, a (above ground):	3 feet
Depth of casing:	13.5 feet
Length, L (from datum):	16.5 feet
Open hole Length, l:	8 feet
Diameter of open hole (D):	4.5 inches
Diameter of casing (d):	4 inches
Constant flow rate, Q:	8.00 gpm
Constant water level (FD):	8.39 feet

Constant flow rate, Q = 8.00 gpm
 = 1.07 feet³/min
 Piezometer head, H_c = 2.11 feet
 Factor of m ($\sqrt{\frac{k_h}{k_v}}$) = 1.00

Permeability, k

$$k = \frac{q \times \ln \left[\frac{ml}{D} + \sqrt{1 + \left(\frac{ml}{D} \right)^2} \right]}{2 \times \pi \times l \times H_c} = \begin{array}{|l} \hline 0.038 \text{ feet/min} \\ \hline 0.019 \text{ cm/s} \\ \hline \end{array}$$

GEOTECHNICAL ENGINEERING EXPLORATION
KAMEHAMEHA HIGHWAY (ROUTE 83)
KAIPAPAU STREAM BRIDGE REPLACEMENT
KOOLAULO, OAHU, HAWAII

Percolation Test Calculation Sheet (Falling Head Method: Well point-filter in uniform soil)

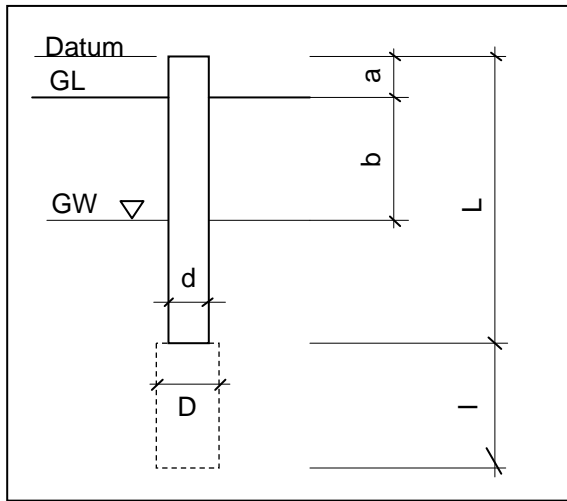

Boring: **B-1 @ 21.5 feet**
 GW table, b (from ground): **7.5 feet**
 Datum, a (above ground): **3 feet**
 Depth of casing: **13.5 feet**
 Length, L (from datum): **16.5 feet**
 Open hole Length, l: **8 feet**
 Diameter of open hole (D): **4.5 inches**
 Diameter of casing (d): **4 inches**

Factor of m ($\sqrt{\frac{k_h}{k_v}}$) = 1.00

Time (min)	Depth of water (from datum) (feet)	Piezometer Head, H _c (feet)
0.0	8.4	2.1
1.0	9.1	1.4
2.0	9.8	0.7
3.0	10.0	0.6
4.0	10.2	0.3
5.0	10.5	0.1
6.0	10.5	0.0

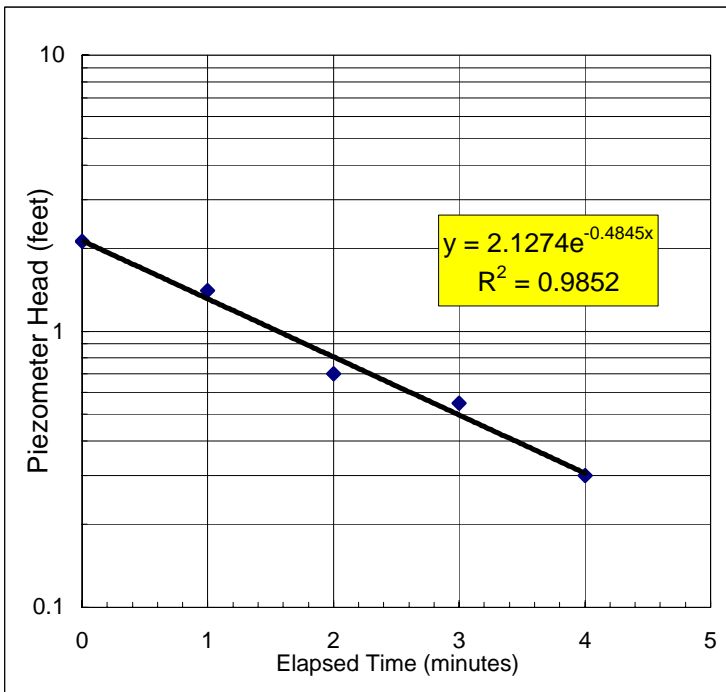

Constant factor of the trendline $y = \lambda e^{cx}$

$\lambda = 2.1274$
 $c = -0.4845$

$\frac{\ln(H_{1c}/H_{2c})}{(t_2-t_1)} = 0.48$

Permeability, k, When $2ml/D \leq 4$,

$$k = \frac{d^2 \times \ln\left[\frac{ml}{D} + \sqrt{1 + \left(\frac{ml}{D}\right)^2}\right]}{8 \times l \times (t_2 - t_1)} \times \ln\left(\frac{H_{1c}}{H_{2c}}\right) = \frac{3.2E-03 \text{ feet/min}}{1.6E-03 \text{ cm/s}}$$

Permeability, k, When $2ml/D > 4$,

$$k = \frac{d^2 \times \ln\left(\frac{2ml}{D}\right)}{8 \times l \times (t_2 - t_1)} \times \ln\left(\frac{H_{1c}}{H_{2c}}\right) = \frac{3.2E-03 \text{ feet/min}}{1.6E-03 \text{ cm/s}}$$

GEOTECHNICAL ENGINEERING EXPLORATION
KAMEHAMEHA HIGHWAY (ROUTE 83)
KAIPAPAU STREAM BRIDGE REPLACEMENT
KOOLAULOA, OAHU, HAWAII

Percolation Test Calculation Sheet (Constant Head Method: Well point-filter in uniform soil)

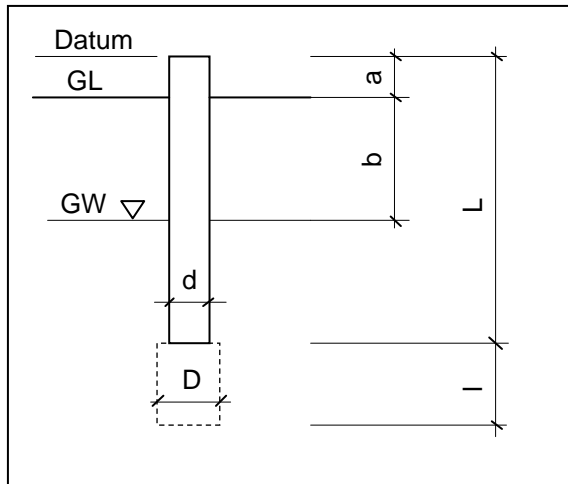

Boring:	B-3 @ 17 feet
GW table, b (from ground):	10.4 feet
Datum, a (above ground):	1.8 feet
Depth of casing:	10.2 feet
Length, L (from datum):	12 feet
Open hole Length, l:	5 feet
Diameter of open hole (D):	4.5 inches
Diameter of casing (d):	4 inches
Constant flow rate, Q:	20.00 gpm
Constant water level (FD):	8.60 feet

Constant flow rate, Q = 20.00 gpm
 = 2.67 feet³/min
 Piezometer head, H_c = 3.60 feet
 Factor of m ($\sqrt{\frac{k_h}{k_v}}$) = 1.00

Permeability, k

$$k = \frac{q \times \ln \left[\frac{ml}{D} + \sqrt{1 + \left(\frac{ml}{D} \right)^2} \right]}{2 \times \pi \times l \times H_c} = \begin{array}{|l} \hline 0.078 \text{ feet/min} \\ \hline 0.039 \text{ cm/s} \\ \hline \end{array}$$

GEOTECHNICAL ENGINEERING EXPLORATION
KAMEHAMEHA HIGHWAY (ROUTE 83)
KAIPAPAU STREAM BRIDGE REPLACEMENT
KOOLAULOA, OAHU, HAWAII

Percolation Test Calculation Sheet (Falling Head Method: Well point-filter in uniform soil)

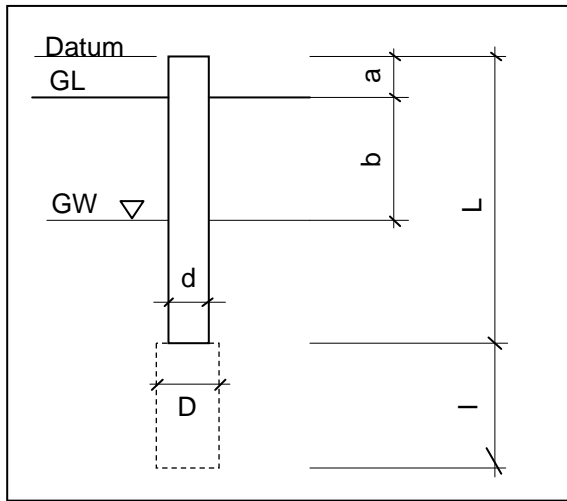

Boring: **B-3 @ 17 feet**
 GW table, b (from ground): **10.4** feet
 Datum, a (above ground): **1.8** feet
 Depth of casing: **10.2** feet
 Length, L (from datum): **12** feet
 Open hole Length, l: **5** feet
 Diameter of open hole (D): **4.5** inches
 Diameter of casing (d): **4** inches

Factor of m ($\sqrt{\frac{k_h}{k_v}}$) = 1.00

Time (min)	Depth of water (from datum) (feet)	Piezometer Head, H _c (feet)
0.0	8.6	3.6
1.0	9.8	2.4
2.0	11.1	1.2
3.0	12.1	0.1

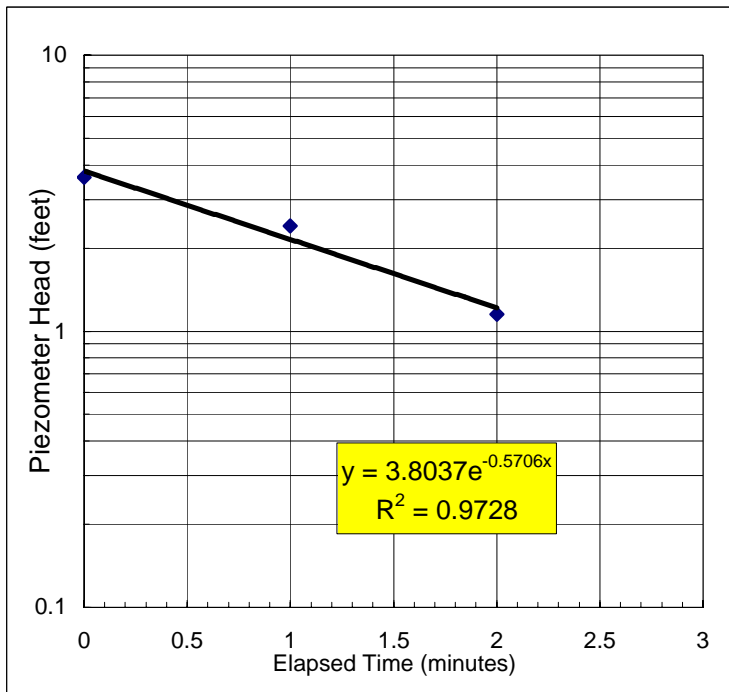

Constant factor of the trendline $y = \lambda e^{cx}$
 $\lambda = 3.8037$
 $c = -0.5706$
 $\frac{\ln(H_{1c} / H_{2c})}{(t_2 - t_1)} = 0.57$

Permeability, k, When $2ml/D \leq 4$,

$$k = \frac{d^2 \times \ln\left[\frac{ml}{D} + \sqrt{1 + \left(\frac{ml}{D}\right)^2}\right]}{8 \times l \times (t_2 - t_1)} \times \ln\left(\frac{H_{1c}}{H_{2c}}\right) = \frac{5.2E-03 \text{ feet/min}}{2.6E-03 \text{ cm/s}}$$

Permeability, k, When $2ml/D > 4$,

$$k = \frac{d^2 \times \ln\left(\frac{2ml}{D}\right)}{8 \times l \times (t_2 - t_1)} \times \ln\left(\frac{H_{1c}}{H_{2c}}\right) = \frac{5.2E-03 \text{ feet/min}}{2.6E-03 \text{ cm/s}}$$

GEOTECHNICAL ENGINEERING EXPLORATION
KAMEHAMEHA HIGHWAY (ROUTE 83)
KAIPAPAU STREAM BRIDGE REPLACEMENT
KOOLAULOA, OAHU, HAWAII

Percolation Test Calculation Sheet (Constant Head Method: Well point-filter in uniform soil)

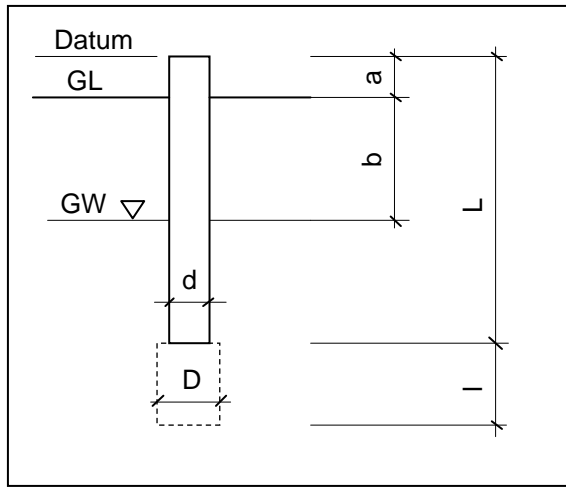

Boring:	B-3 @ 22 feet
GW table, b (from ground):	10.5 feet
Datum, a (above ground):	2 feet
Depth of casing:	17 feet
Length, L (from datum):	19 feet
Open hole Length, l:	5 feet
Diameter of open hole (D):	4.5 inches
Diameter of casing (d):	4 inches
Constant flow rate, Q:	12.00 gpm
Constant water level (FD):	8.55 feet

Constant flow rate, Q = 12.00 gpm
 = 1.60 feet³/min
 Piezometer head, H_c = 3.95 feet
 Factor of m ($\sqrt{\frac{k_h}{k_v}}$) = 1.00

Permeability, k

$$k = \frac{q \times \ln \left[\frac{ml}{D} + \sqrt{1 + \left(\frac{ml}{D} \right)^2} \right]}{2 \times \pi \times l \times H_c} = \begin{array}{|l} \hline 0.042 \text{ feet/min} \\ \hline 0.022 \text{ cm/s} \\ \hline \end{array}$$

GEOTECHNICAL ENGINEERING EXPLORATION
KAMEHAMEHA HIGHWAY (ROUTE 83)
KAIPAPAU STREAM BRIDGE REPLACEMENT
KOOLAULO, OAHU, HAWAII

Percolation Test Calculation Sheet (Falling Head Method: Well point-filter in uniform soil)

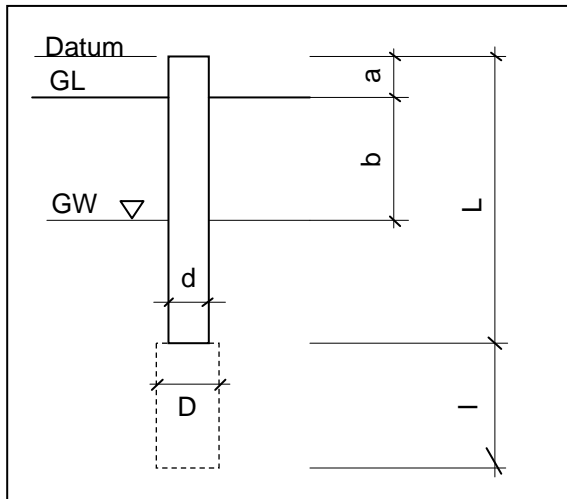

Boring: **B-3 @ 22 feet**
 GW table, b (from ground): **10.5** feet
 Datum, a (above ground): **2** feet
 Depth of casing: **17** feet
 Length, L (from datum): **19** feet
 Open hole Length, l: **5** feet
 Diameter of open hole (D): **4.5** inches
 Diameter of casing (d): **4** inches

Factor of m ($\sqrt{\frac{k_h}{k_v}}$) = 1.00

Time (min)	Depth of water (from datum) (feet)	Piezometer Head, H _c (feet)
0.0	8.6	4.0
1.0	10.9	1.6
2.0	11.1	1.5
3.0	11.2	1.3
4.0	11.3	1.2
5.0	11.5	1.1
10.0	12.5	0.0

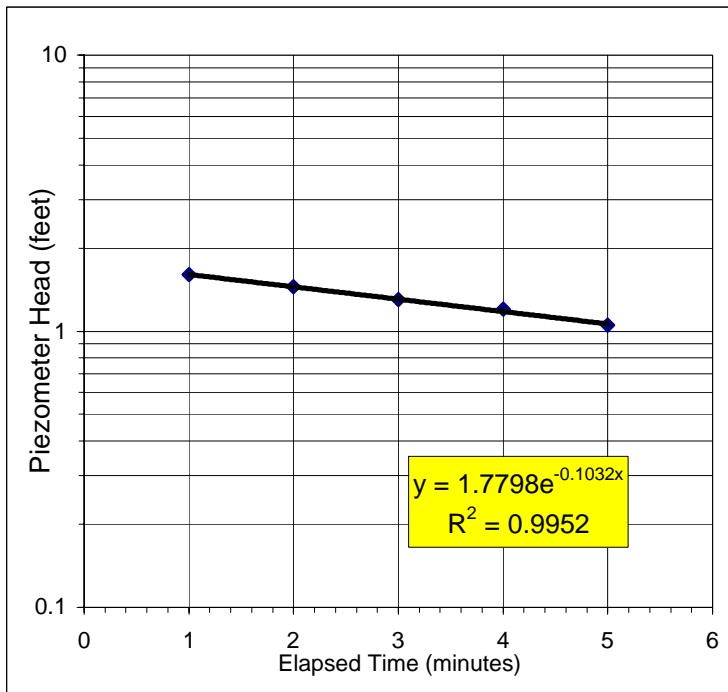

Constant factor of the trendline $y = \lambda e^{cx}$

$\lambda =$	1.7798
$c =$	-0.1032
$\frac{\ln(H_{1c}/H_{2c})}{(t_2-t_1)}$	= 0.10

Permeability, k, When $2ml/D \leq 4$,

$$k = \frac{d^2 \times \ln\left[\frac{ml}{D} + \sqrt{1 + \left(\frac{ml}{D}\right)^2}\right]}{8 \times l \times (t_2 - t_1)} \times \ln\left(\frac{H_{1c}}{H_{2c}}\right) = \frac{9.4E-04 \text{ feet/min}}{4.8E-04 \text{ cm/s}}$$

Permeability, k, When $2ml/D > 4$,

$$k = \frac{d^2 \times \ln\left(\frac{2ml}{D}\right)}{8 \times l \times (t_2 - t_1)} \times \ln\left(\frac{H_{1c}}{H_{2c}}\right) = \frac{9.4E-04 \text{ feet/min}}{4.8E-04 \text{ cm/s}}$$

APPENDIX D

B-1 31.0' TO 66.0'

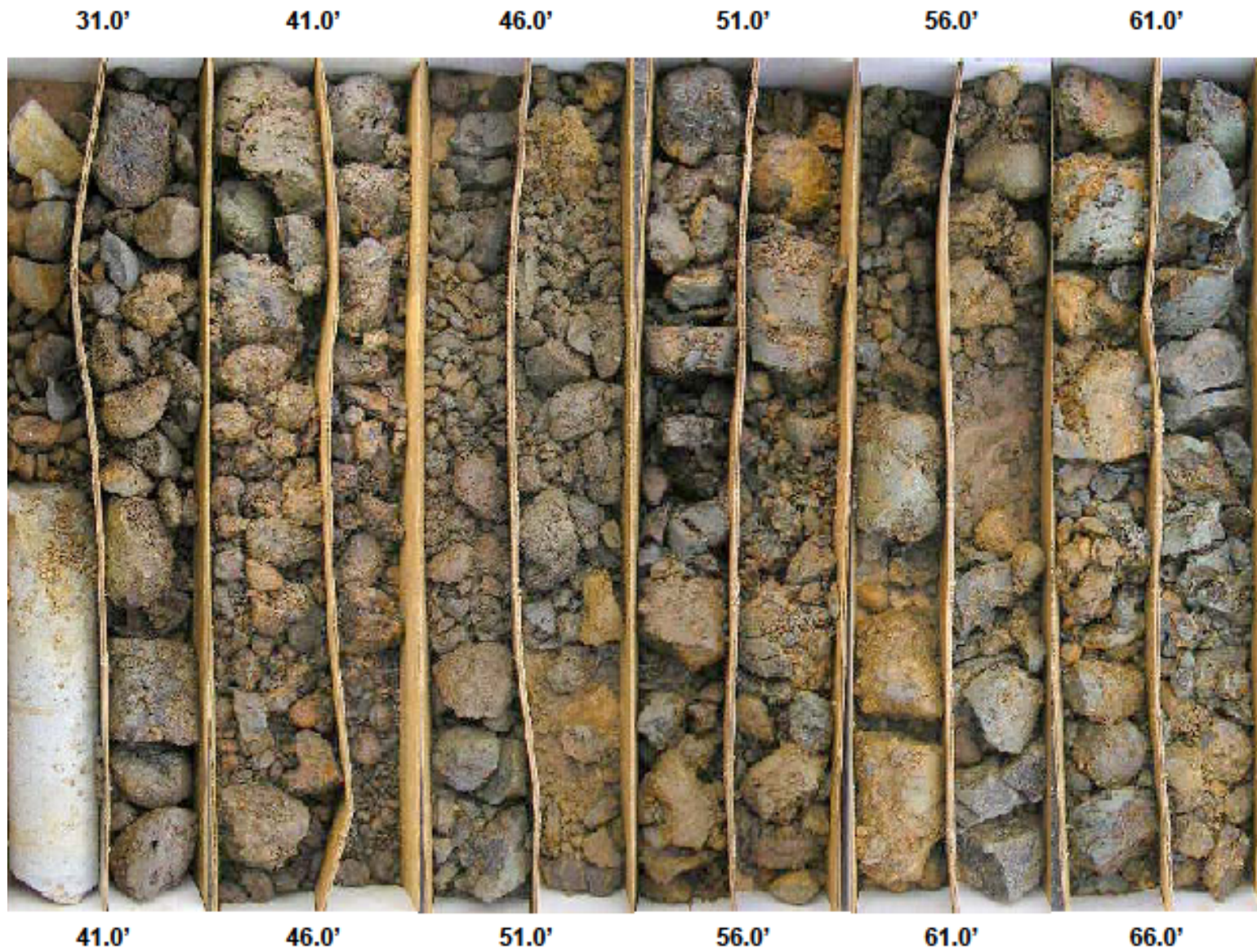

B-1 66.0' TO 110.0'

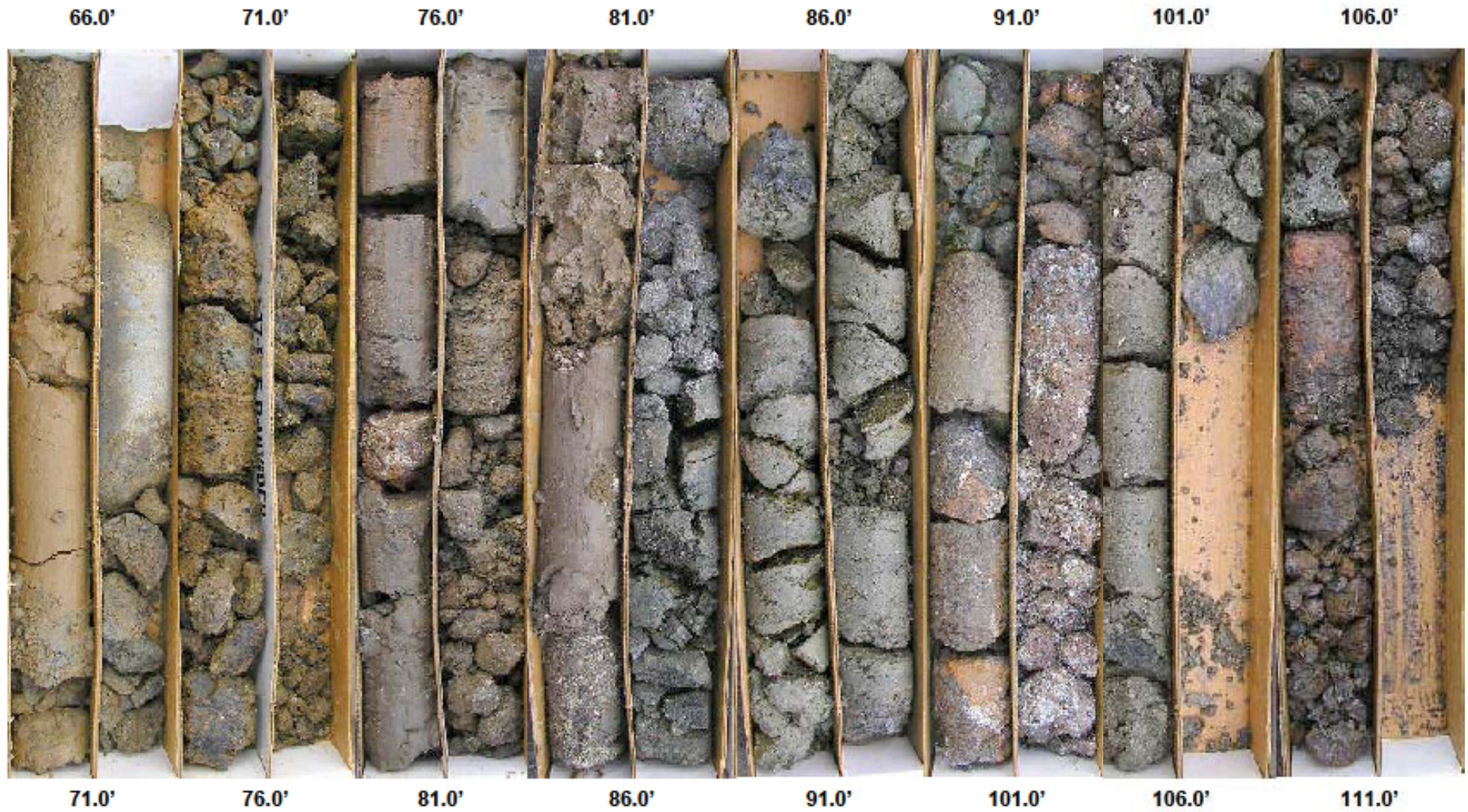

B-2 17.0' TO 57.0'

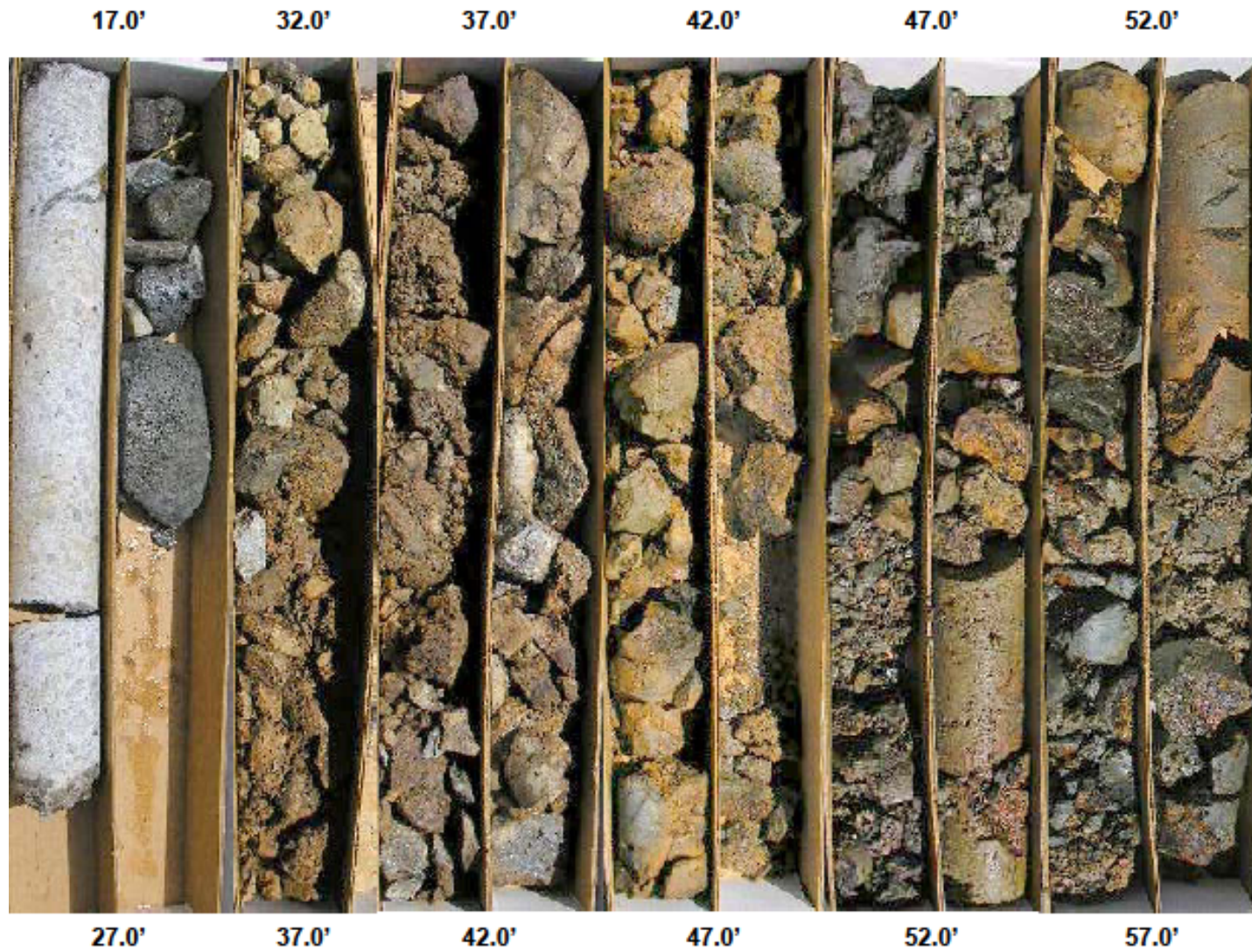

B-2 57.0' TO 87.0'

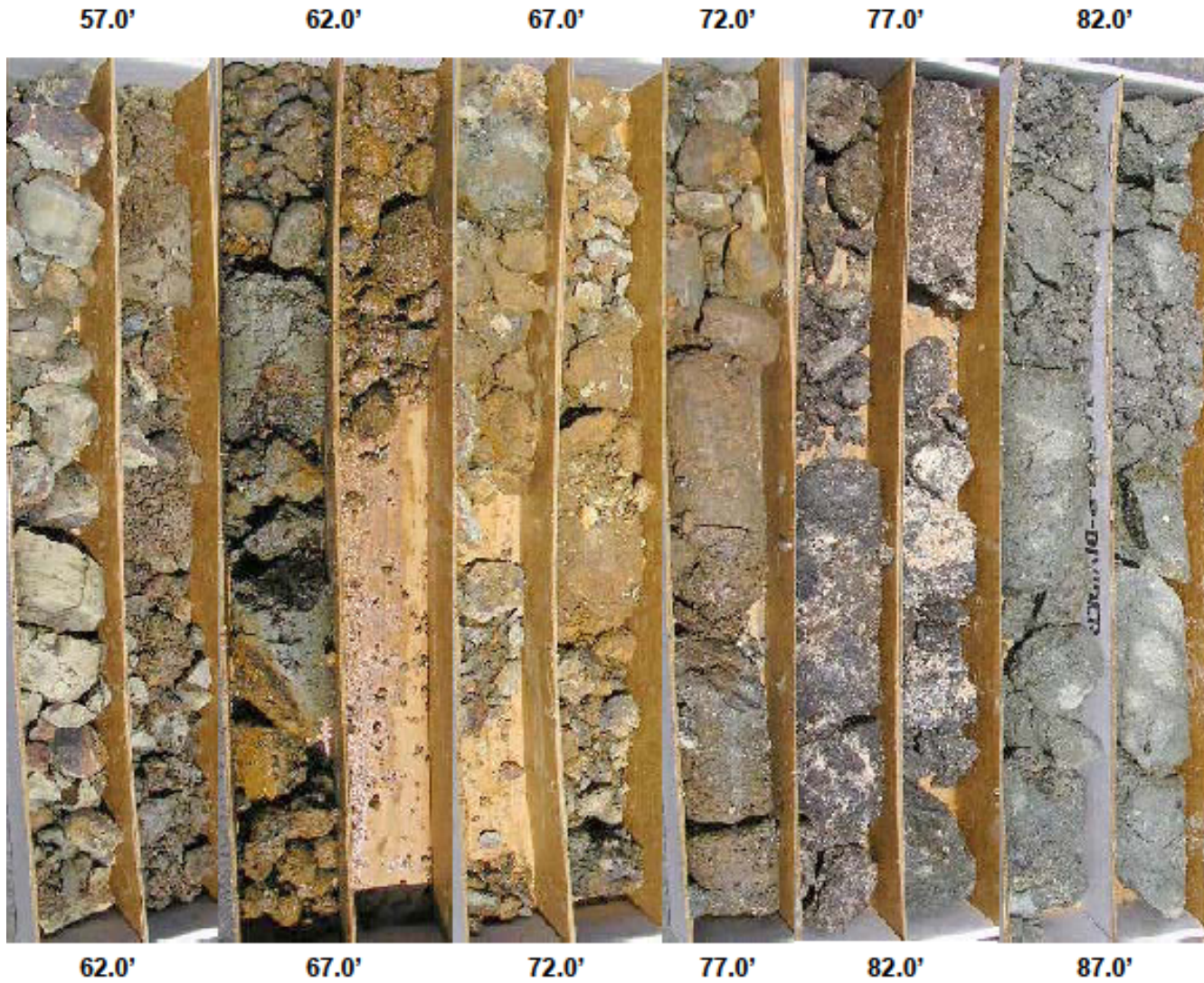

B-2 87.0' TO 112.0'



B-3 57.0' TO 87.0'

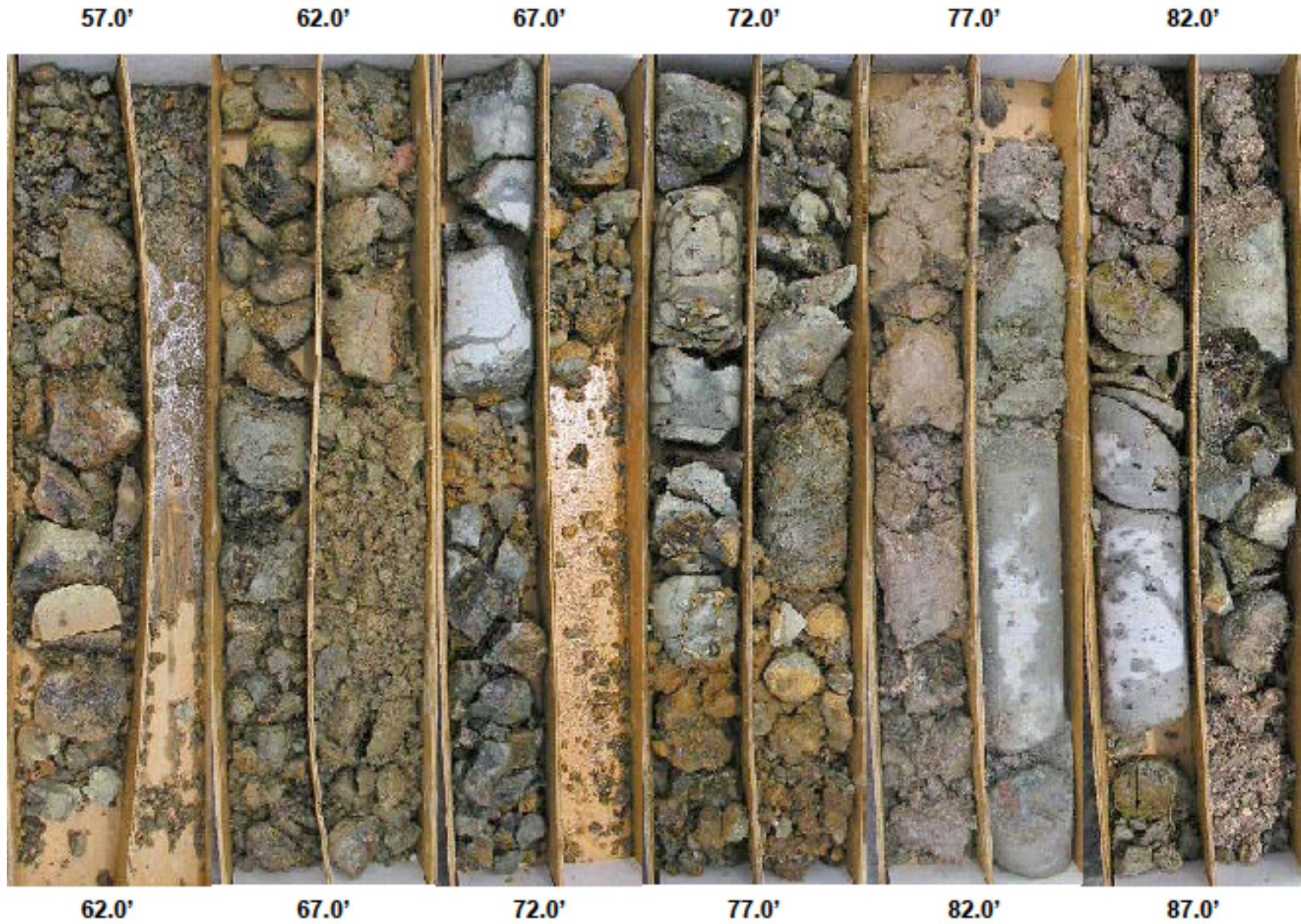

B-3 87.0' TO 112.0'

87.0'

92.0'

97.0'

102.0'

107.0'



92.0'

97.0'

102.0'

107.0'

112.0'

CONCRETE
 Original quantity - 74.5 Cu. Yds
 Less in base - 1.6 " "
 Revised quantity 72.9 " "

ADDITIONAL STEEL
 8-72 lbs of 1/2" φ 5/8" φ.

NOTE
 See sheet No. 4251.31 for further data not shown here.

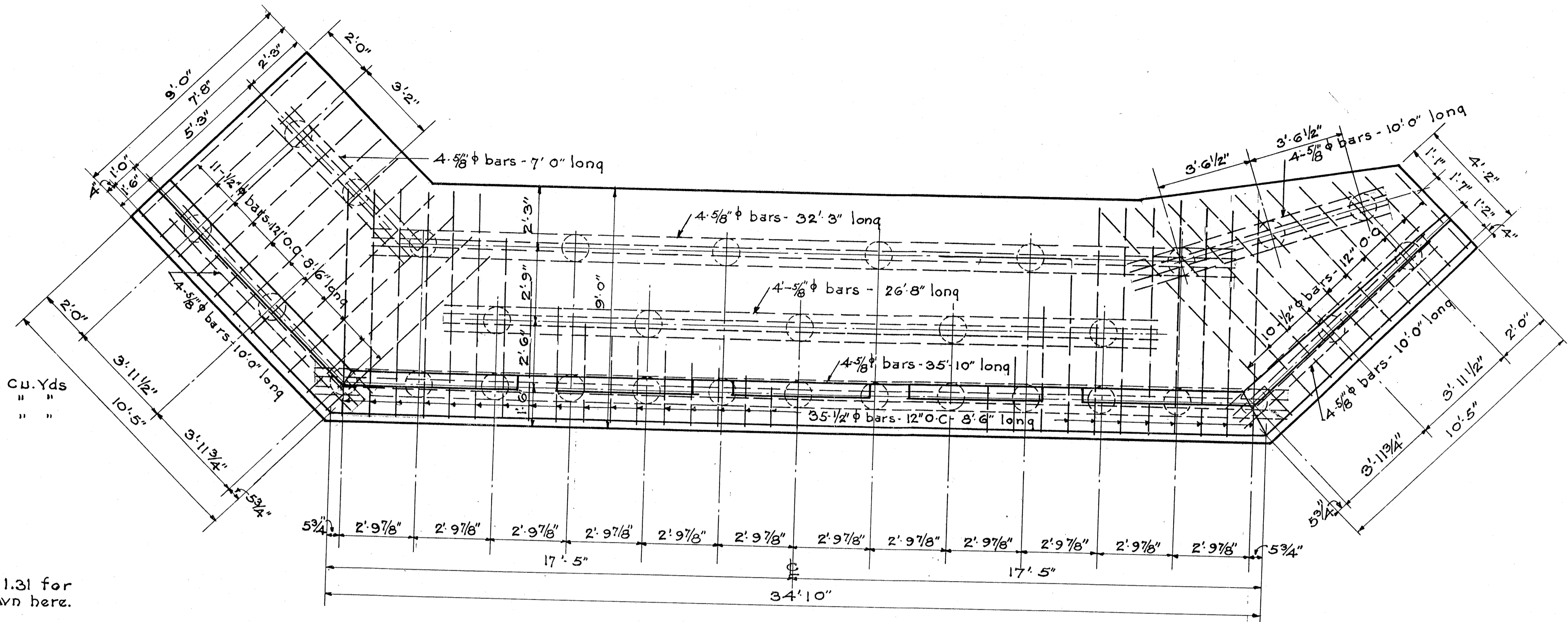

PLAN OF NORTH ABUTMENT
 Scale 3/8" = 1'-0"
32 PILES

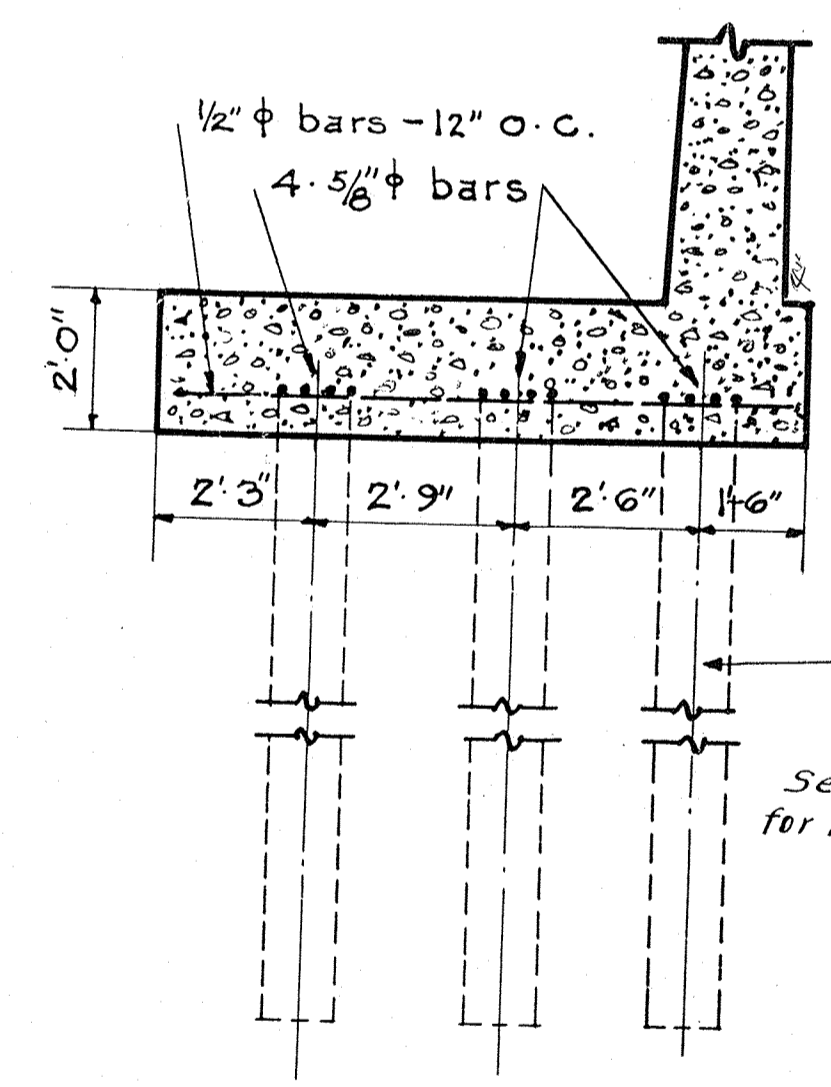

SECTION
 Scale 3/8" = 1'-0"

Wooden piles 20' long
 See construction pile record for lengths of pile used.

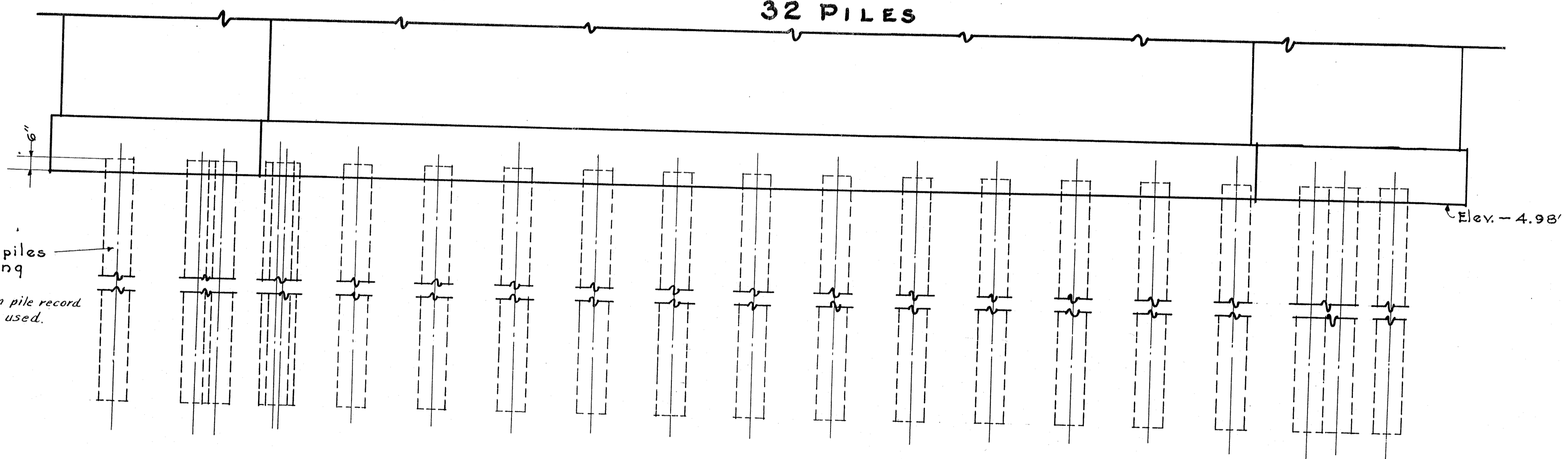

ELEVATION OF NORTH ABUTMENT
 Scale 3/8" = 1'-0"

APPROVED
L. H. Wiggin
 TERRITORIAL HIGHWAY ENGINEER

REVISED DETAILS FOR
 NORTH ABUTMENT
KAIPAPAU BRIDGE
 No. 17 - STA. 1247+92
 SEPT. 20, 1932

Existing Kaipapau
 Kaipapau abutments (and other bridges) in this area same as shown on 07/17/32

C.R.M. — 46 C.Y.
Excavation — 55 C.Y.

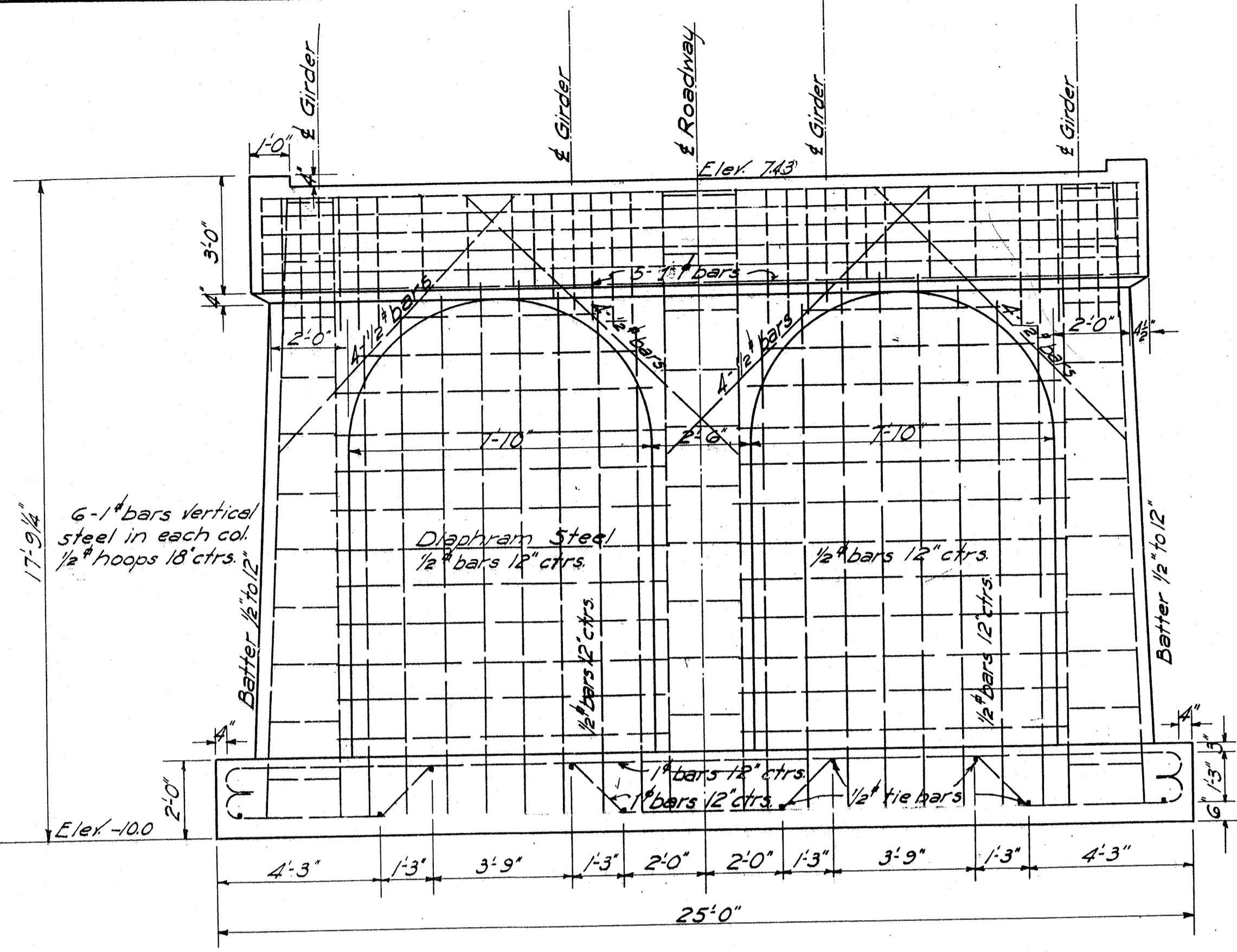

ELEVATION CENTER PIER & CAP
Scale: 3/8"=1'-0"

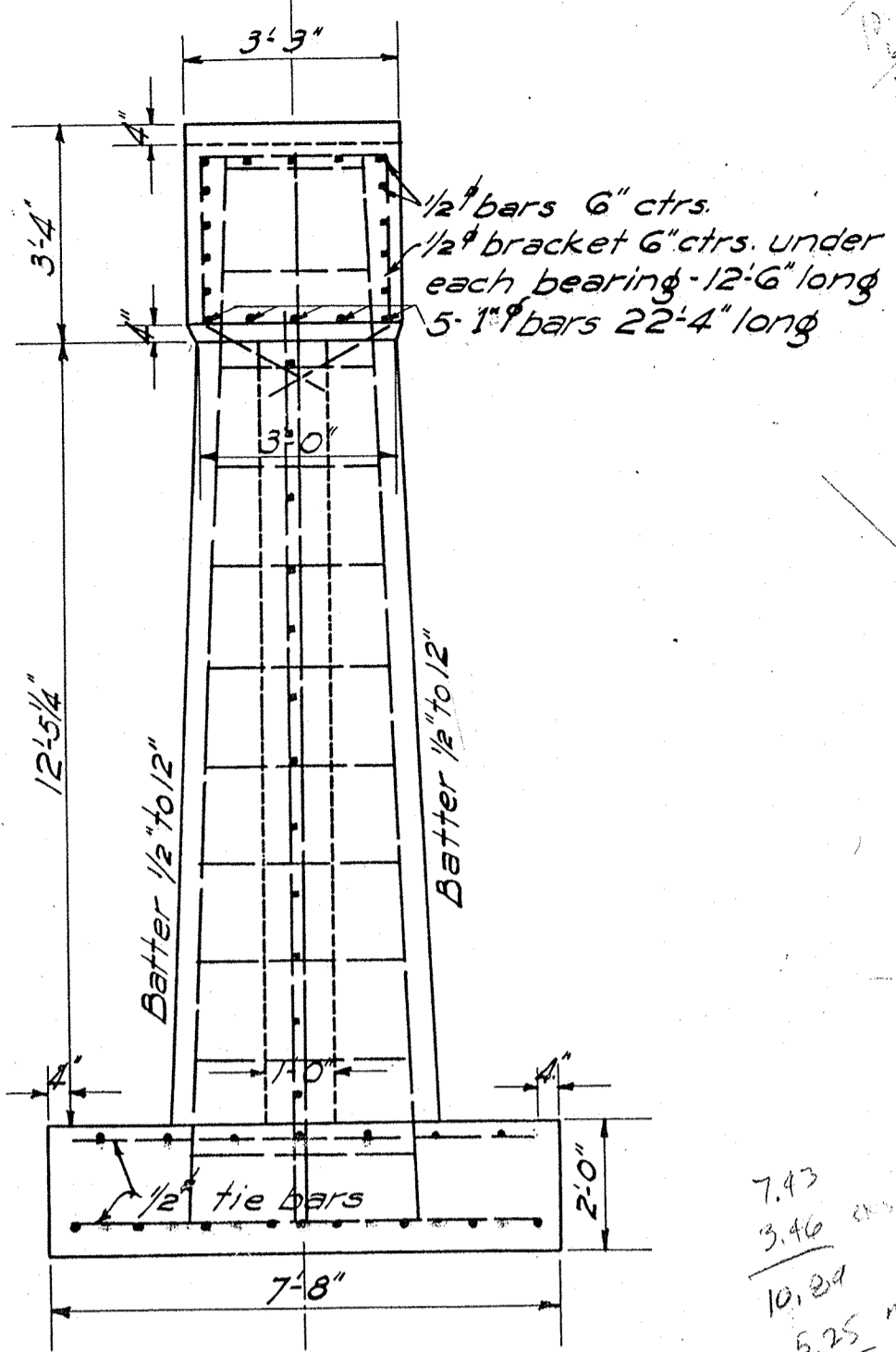

END ELEVATION
Scale: 3/8"=1'-0"

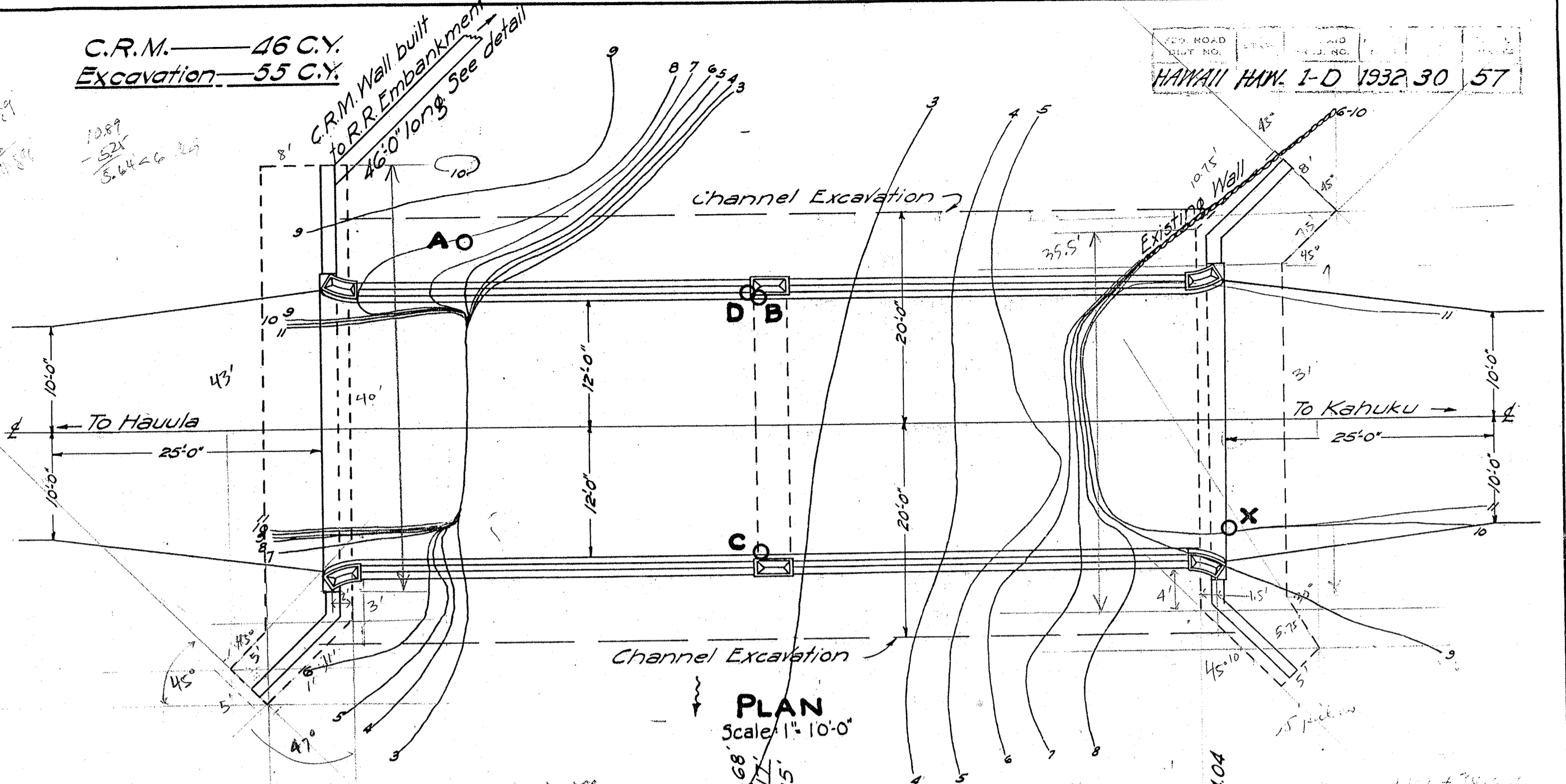

PLAN
Scale: 1"=10'-0"

7.43
3.46
10.24
5.25
5.64
Camber 0.11%
Elev 11.85

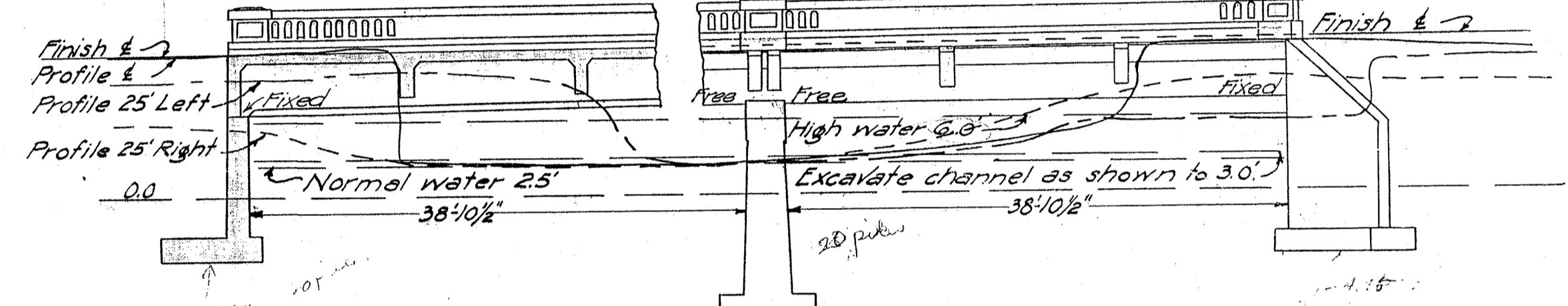

PROFILES
Scale: 1"=10'-0"

GENERAL NOTES

- Dead Load — Concrete at 150 # per cubic foot.
- Live Load — 2-15 ton trucks with 30% allowance for impact
- Concrete — All Class "A" (1:2:4 mix) with all exposed corners chamfered 3/4" unless otherwise noted. Allowable compression 650# per sq. ft.
- Reinforcing Steel — Allowable tensile stress 16,000# per sq. in. All steel to be round or square deformed bars, square twisted bars not to be considered deformed. All dimensions relating to reinforcement are to centers of bars unless otherwise noted. Where splicing of reinforcement is necessary, bars to be lapped 40 diameters and splices are to be staggered. Main longitudinal bars in girders cannot be spliced. No allowance has been made in quantities for extra weight of steel required for splices. Unless otherwise noted the minimum covering measured from the surface of concrete to the face of any steel shall be not less than 2" in beams, girders, and handrails, and 1 1/4" in slabs. Steel to be held rigidly and accurately in place before and during placing of concrete.
- Foundations — All elevations shown may be changed upon order of the Engineer.

	CONCRETE CLASS "A"	REINFORCING STEEL	STRUCTURE EXCAVATION
S. Abutment	68.1 C.Y.	7044.8 #	260.0 C.Y.
N. Abutment	74.5 "	7334.3 "	294.0 "
Center Pier	42.2 "	3910.0 "	126.0 "
Superstructure	155.8 "	29083.6 "	
Total	340.6 C.Y.	47372.7 #	680.0 C.Y.

Channel Excavation 250.0 Y.

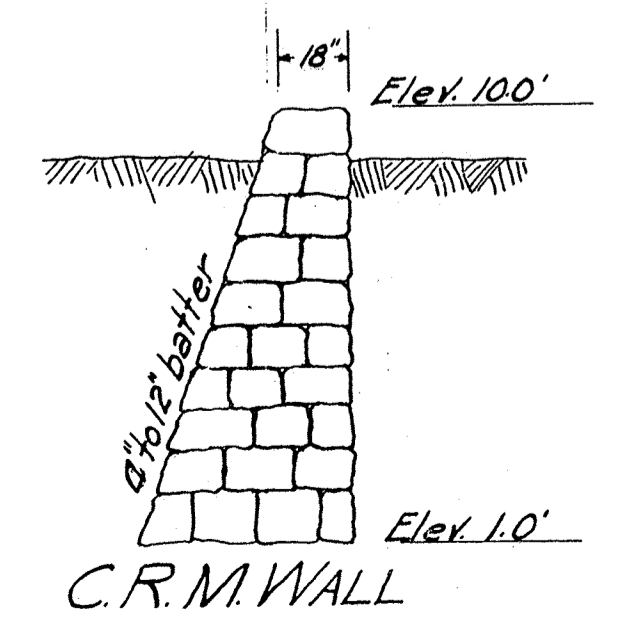
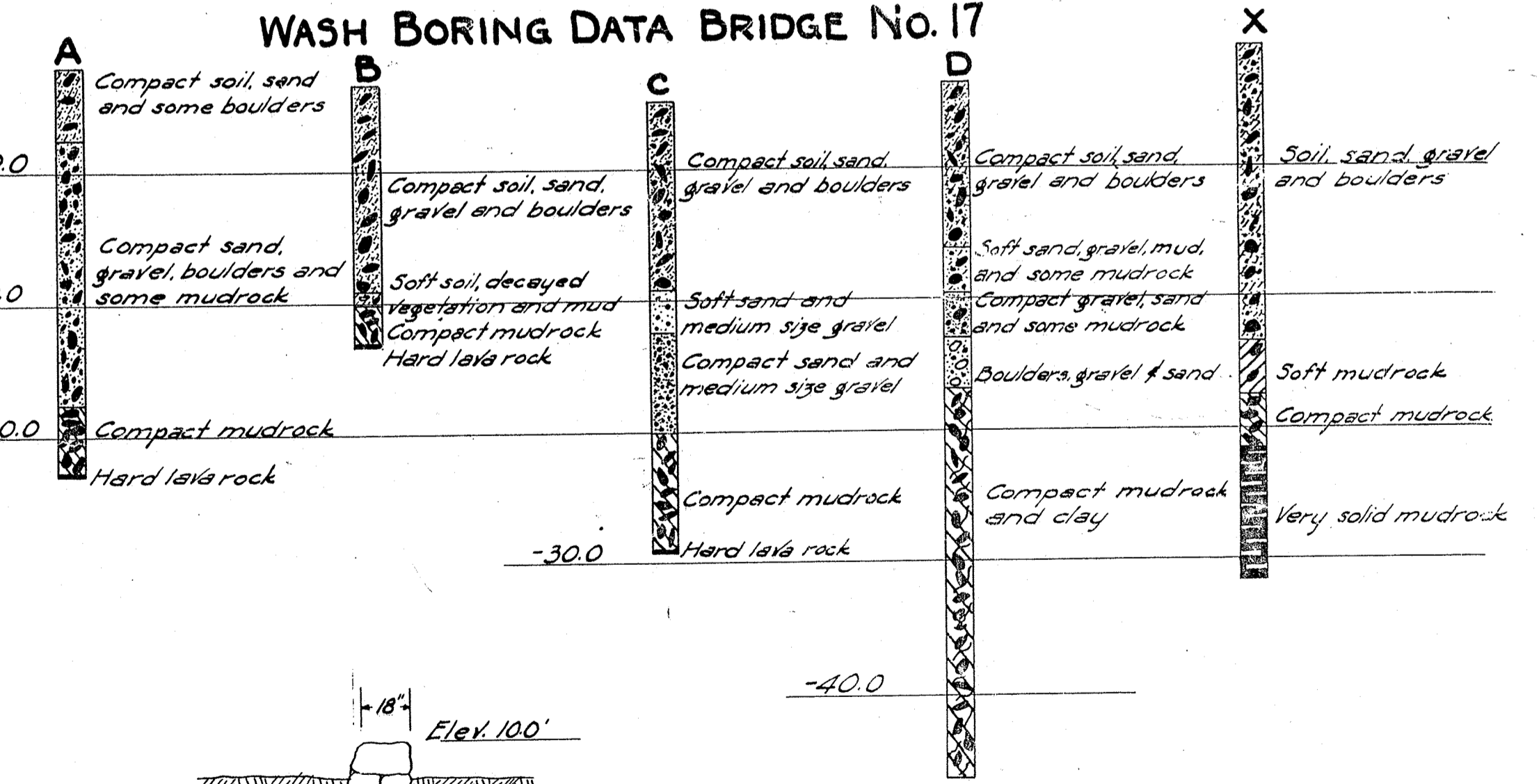

C.R.M. WALL
Sta 1247+50 - left
Scale: 1/4"=1'-0"
Provide 4 Weep Holes at 10' ctrs. at Elev. 4.0'

LOCATION PLAN AND PIER
KAIPAPAU BRIDGE
NO. 17 STA. 1247+92
FEBRUARY 1932
Scale as noted
SHEET 1

USE SUPERSTRUCTURE SHOWN ON PLAN OF
STANDARD DECK GIRDER SUPERSTRUCTURE
40' Span 24' Roadway

Land Court Application No 999
 Lot 4
 $\Delta = 13^{\circ}42'30''$
 $D = 7'$
 $R = 819.0$
 $T = 98.45$
 $L.C. = 195.48$
 $L = 195.95$

$\Delta = 11^{\circ}20'$
 $D = 3'$
 $R = 1910.08$
 $T = 189.53$
 $L.C. = 377.21$
 $L = 377.82$

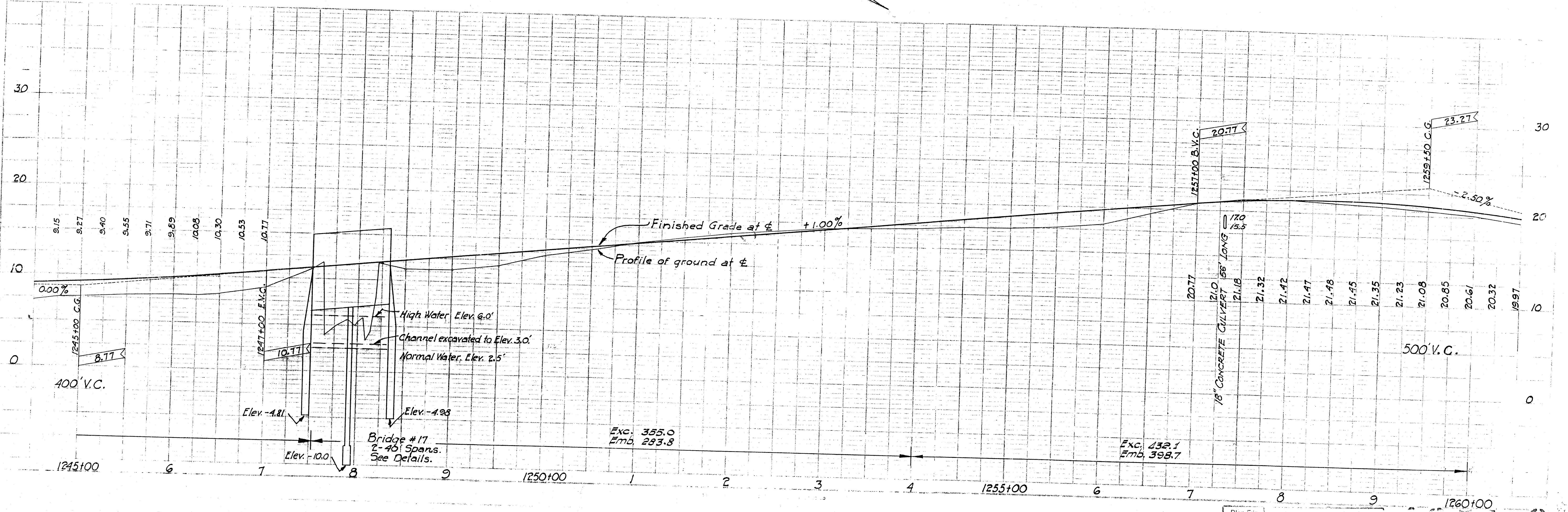
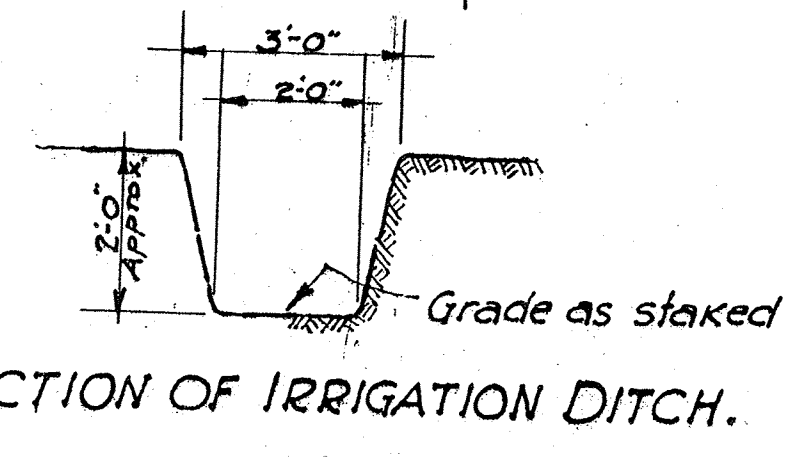
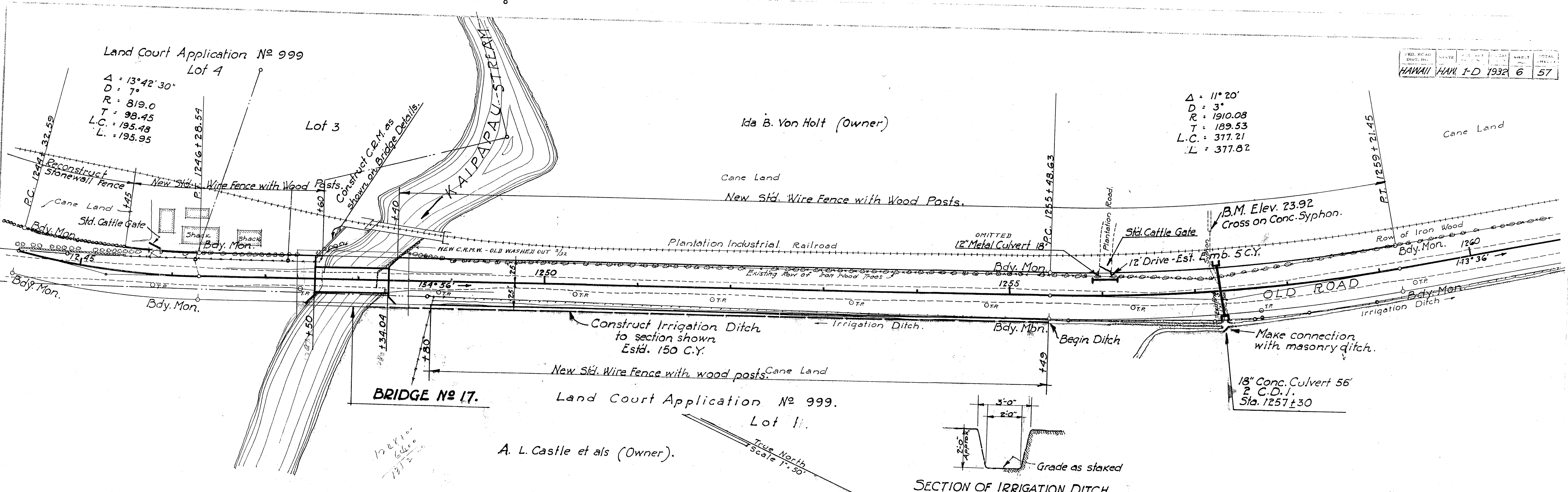

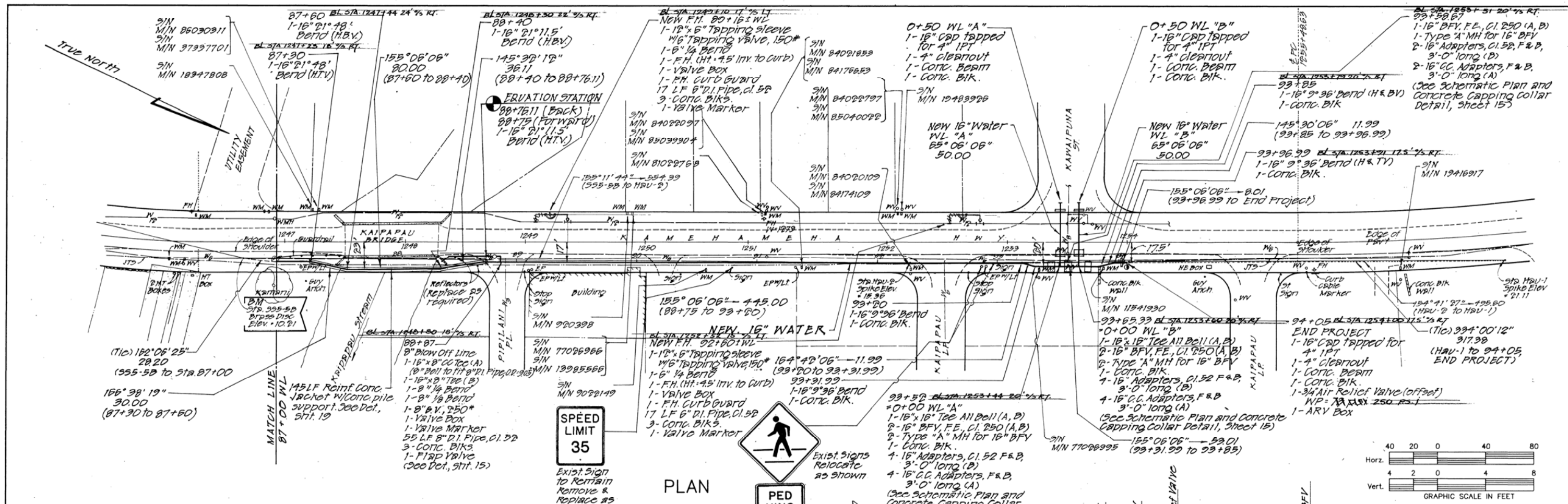

PLAN

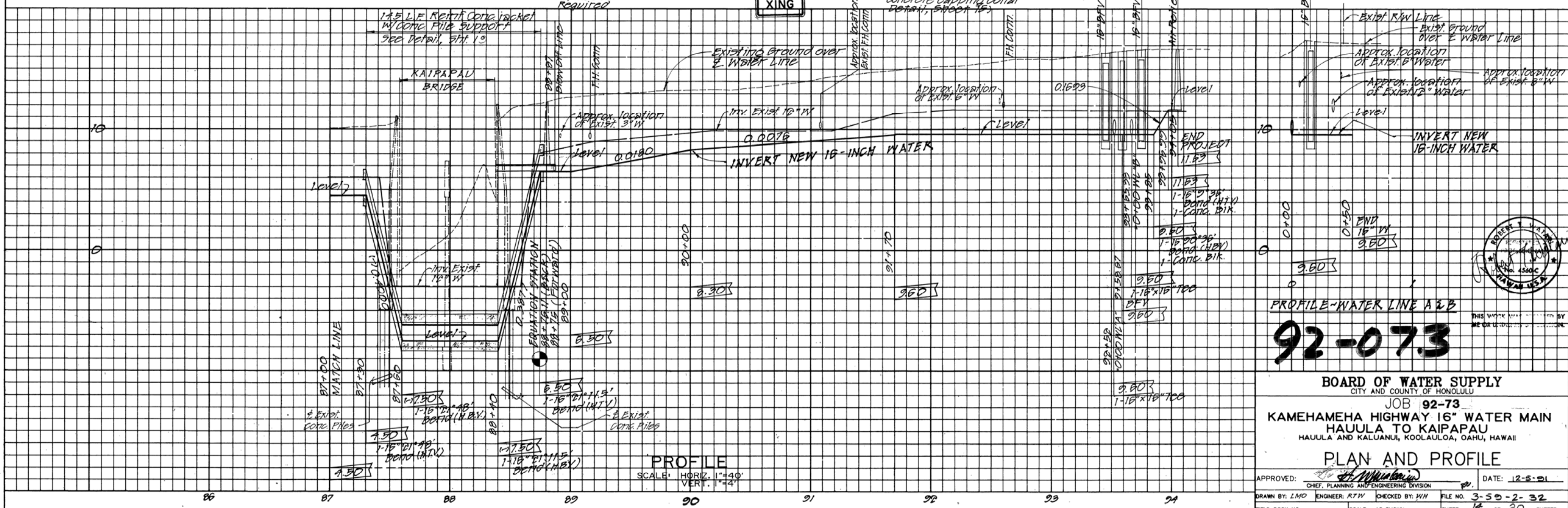
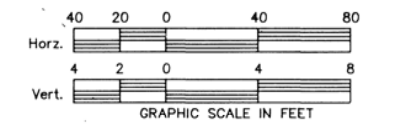

PROFILE

SCALE: HORIZ. 1"=40' VERT. 1"=4'

92-073

BOARD OF WATER SUPPLY
CITY AND COUNTY OF HONOLULU
JOB 92-73
KAMEHAMEHA HIGHWAY 16" WATER MAIN
HAULUA TO KAIAPAU
HAULUA AND KALUANUI, KOOLAULOA, OAHU, HAWAII

PLAN AND PROFILE

APPROVED: [Signature] DATE: 12-5-91
CHIEF, PLANNING AND ENGINEERING DIVISION
DRAWN BY: LMD ENGINEER: RTH CHECKED BY: WH FILE NO. 3-50-2-32
FIELD BOOK NO. SCALE: AS SHOWN SHEET 14 OF 20 SHEETS

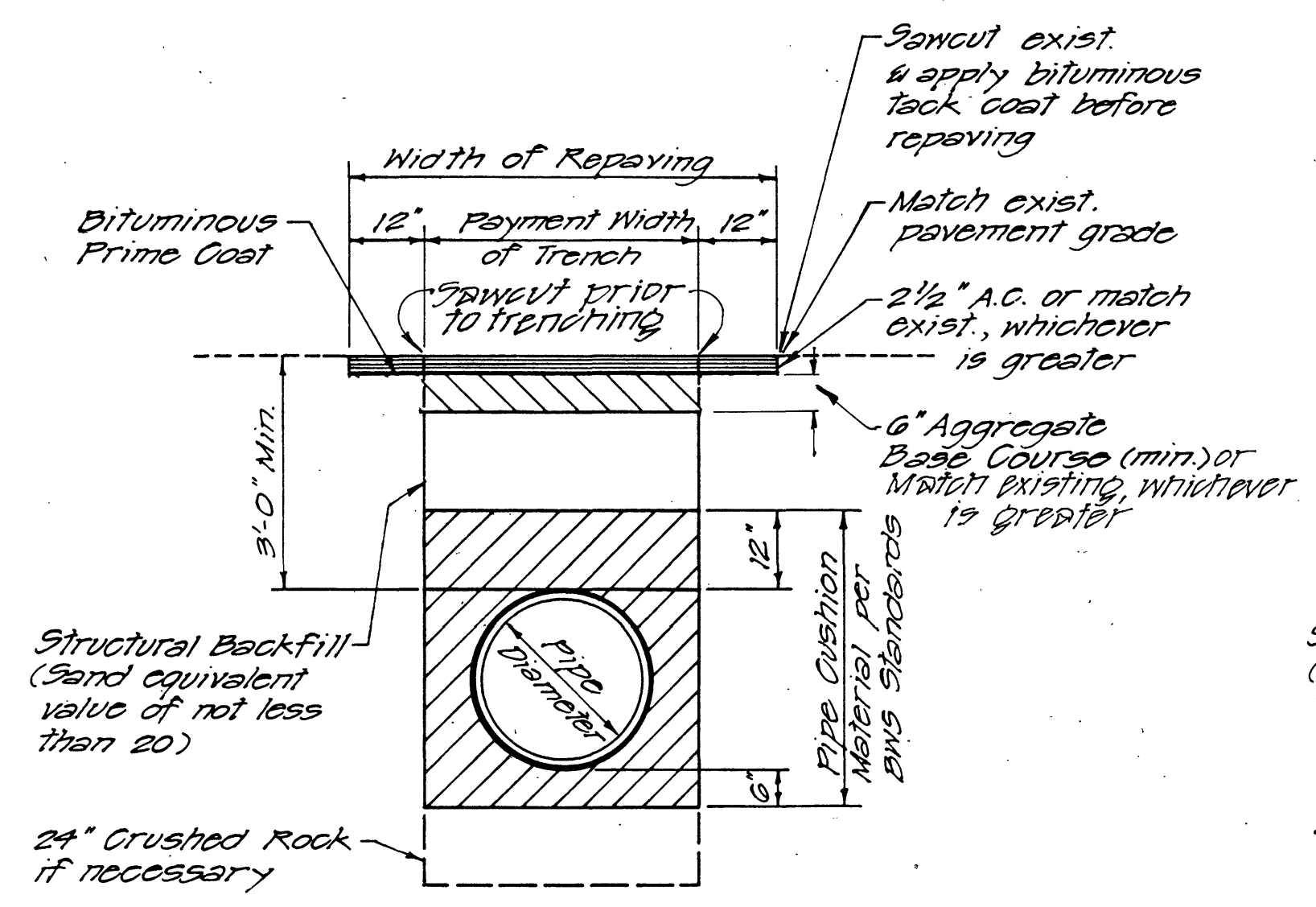

PAVED SHOULDER AREA AND PAVED DRIVEWAYS

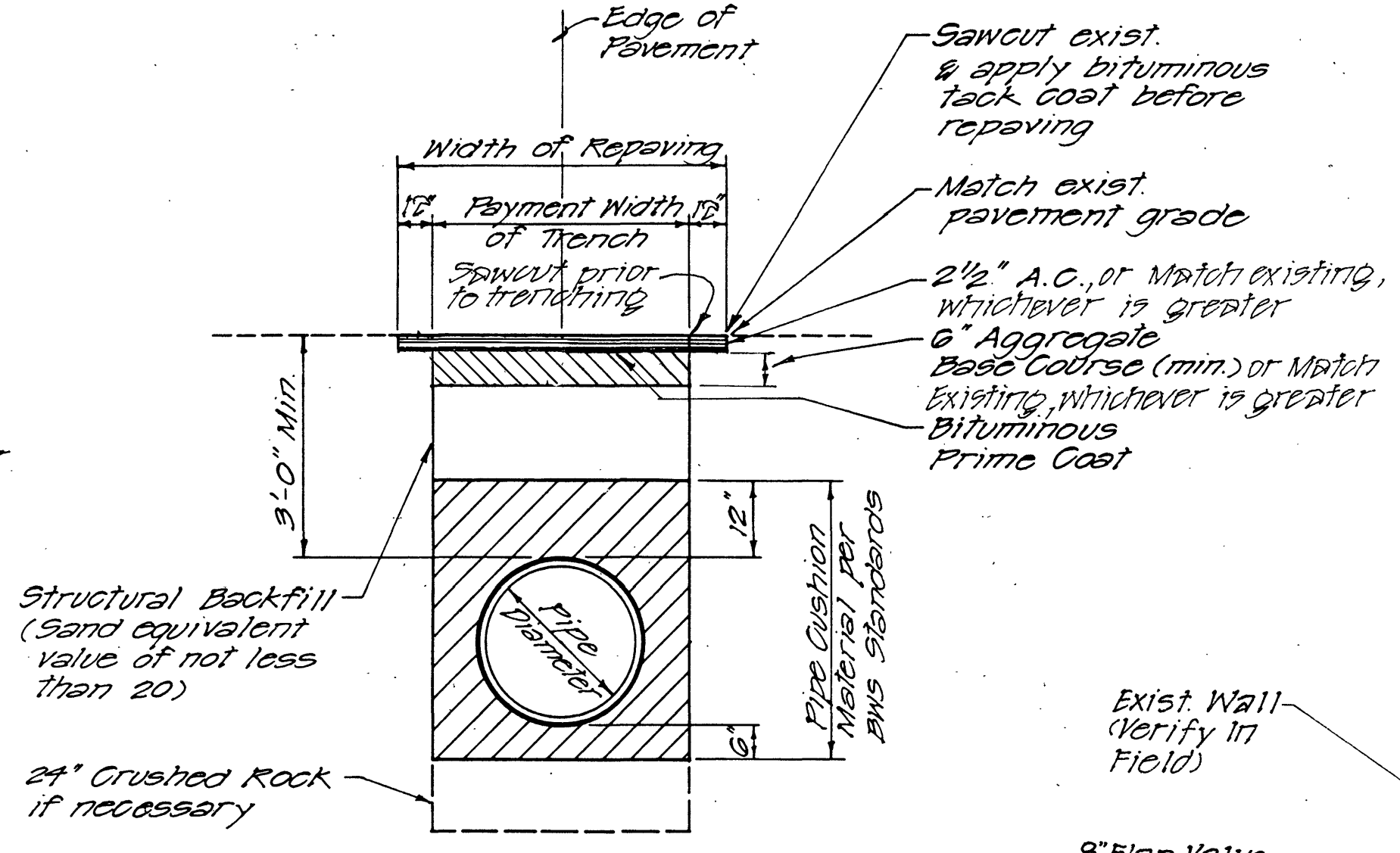

PAVED SHOULDER AREA AT EDGE PAVEMENT

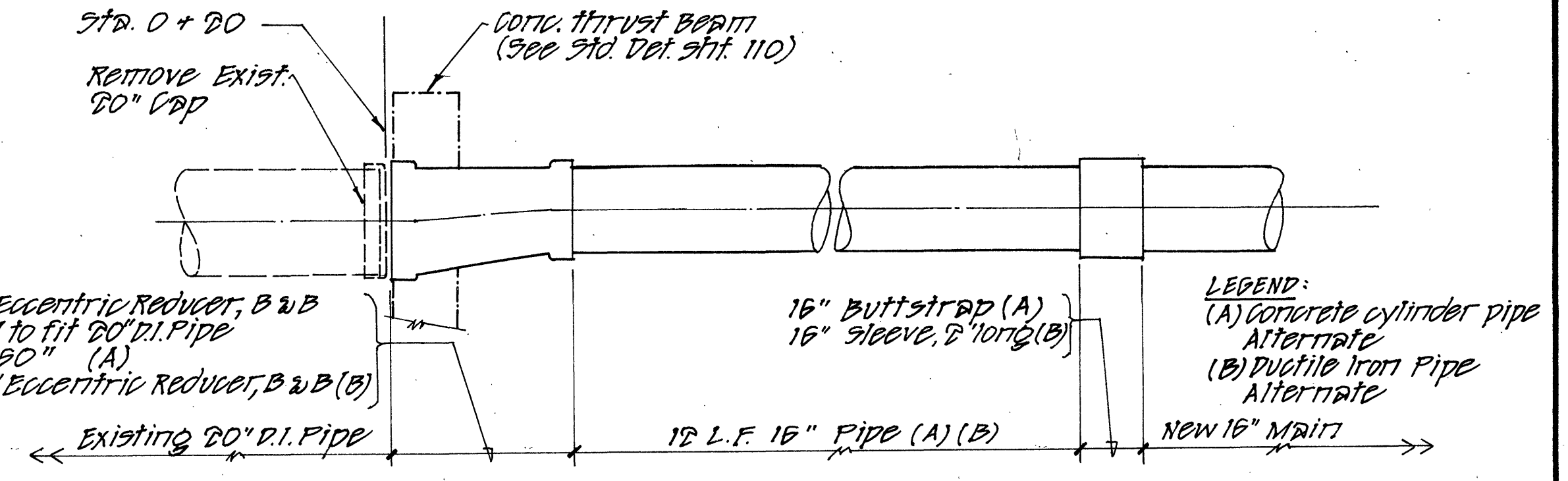

SCHEMATIC CONNECTION DETAIL ~ 9TA. 0 + 20
NOT TO SCALE

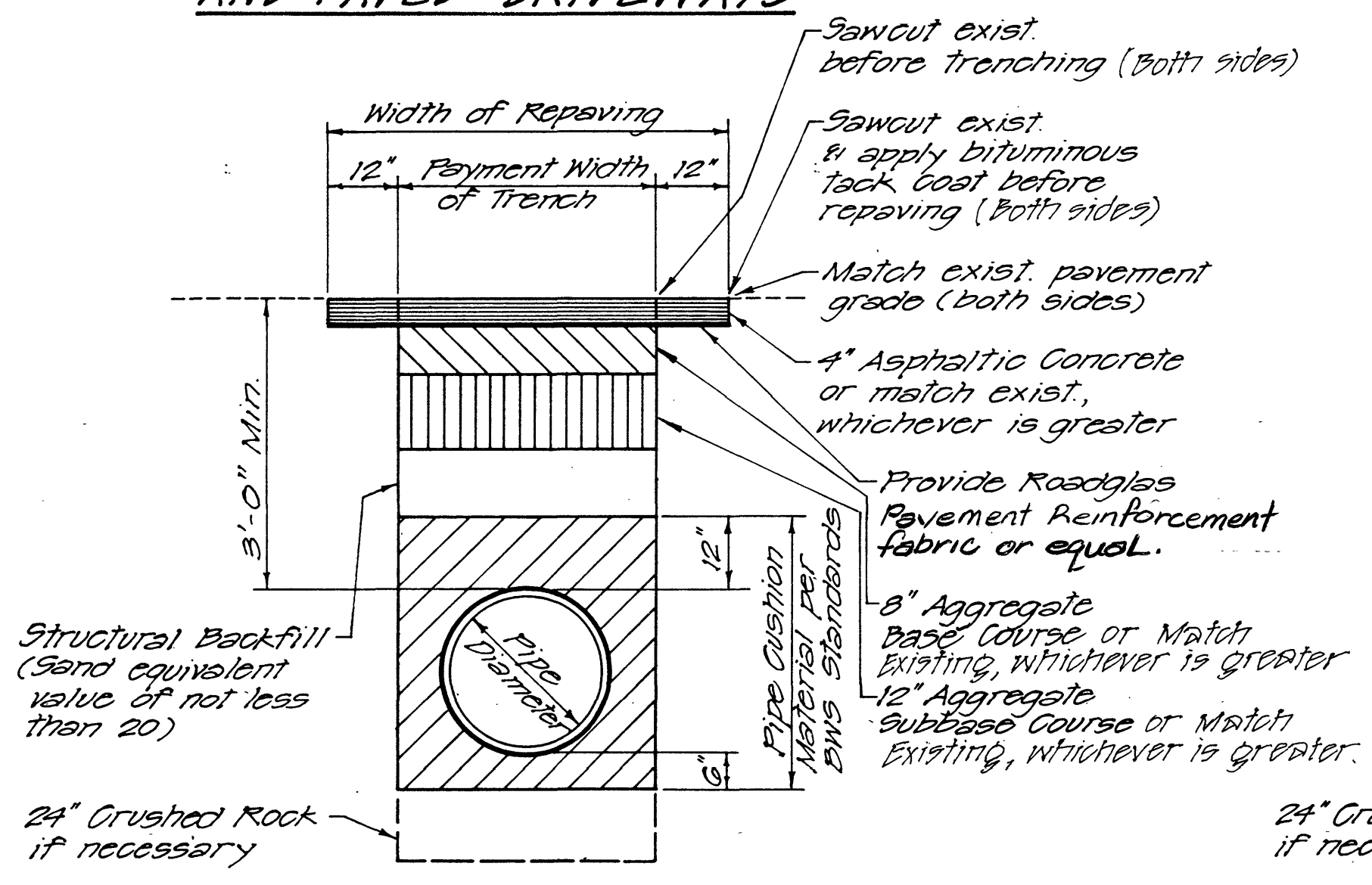

PAVEMENT AREA

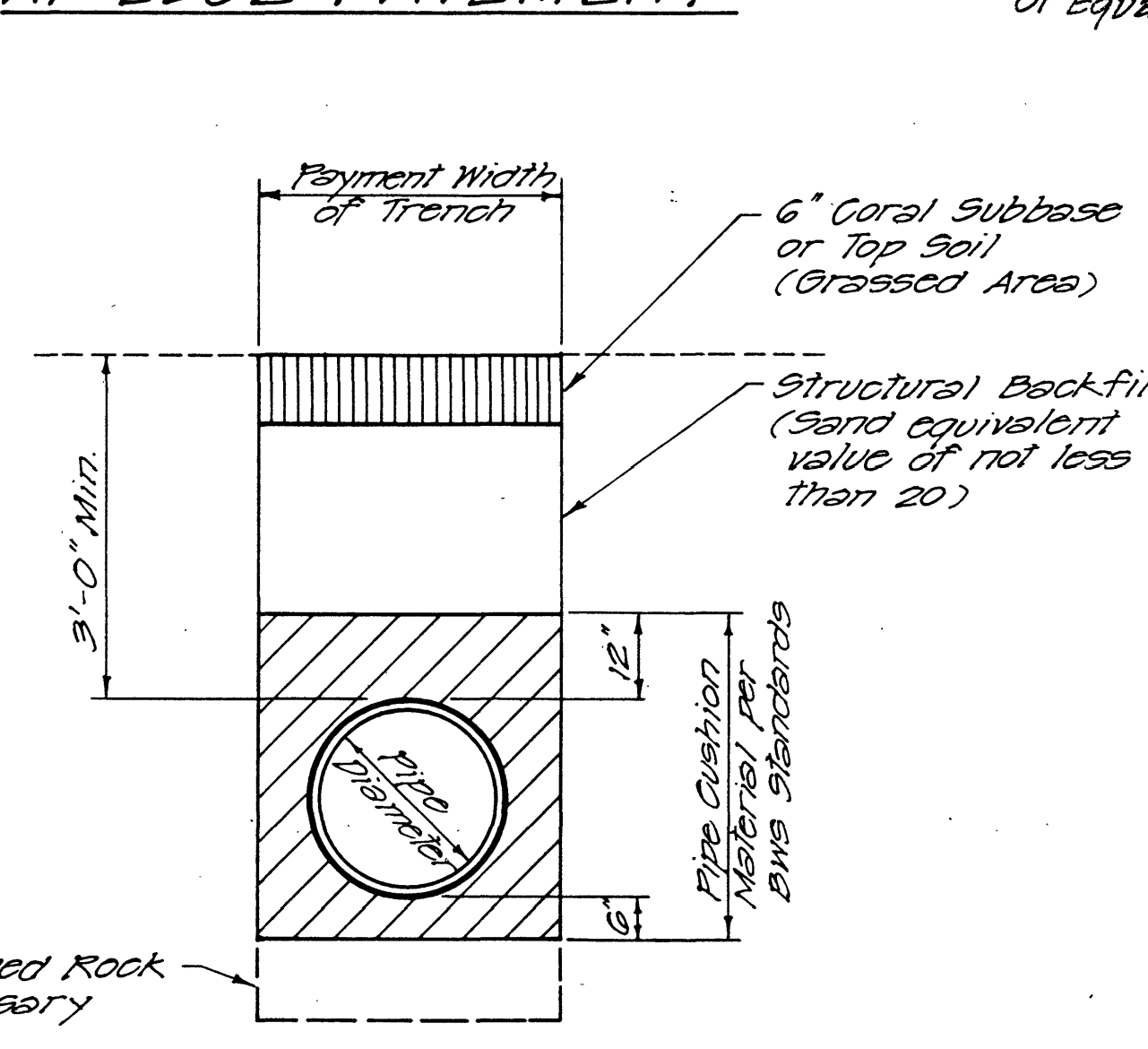

UNPAVED AREA OR GRASSED AREA

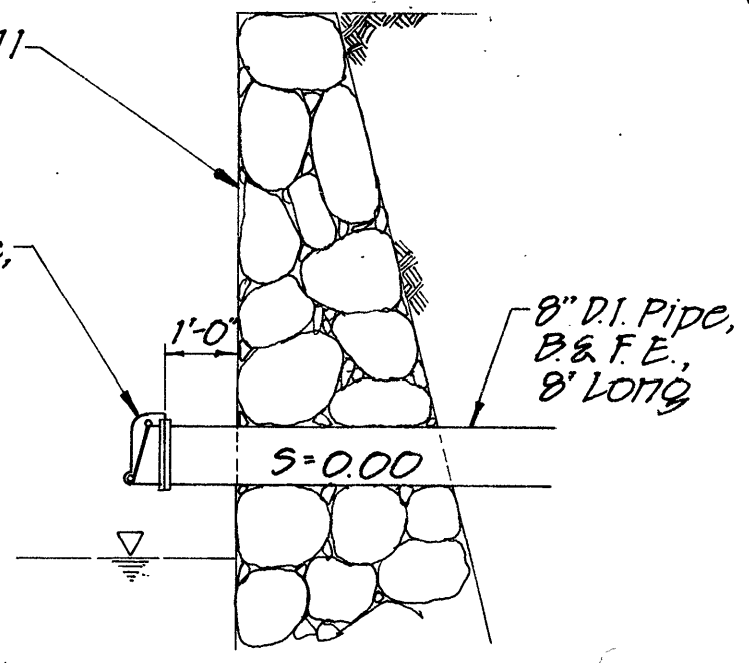

FLAP VALVE DETAIL
NOT TO SCALE

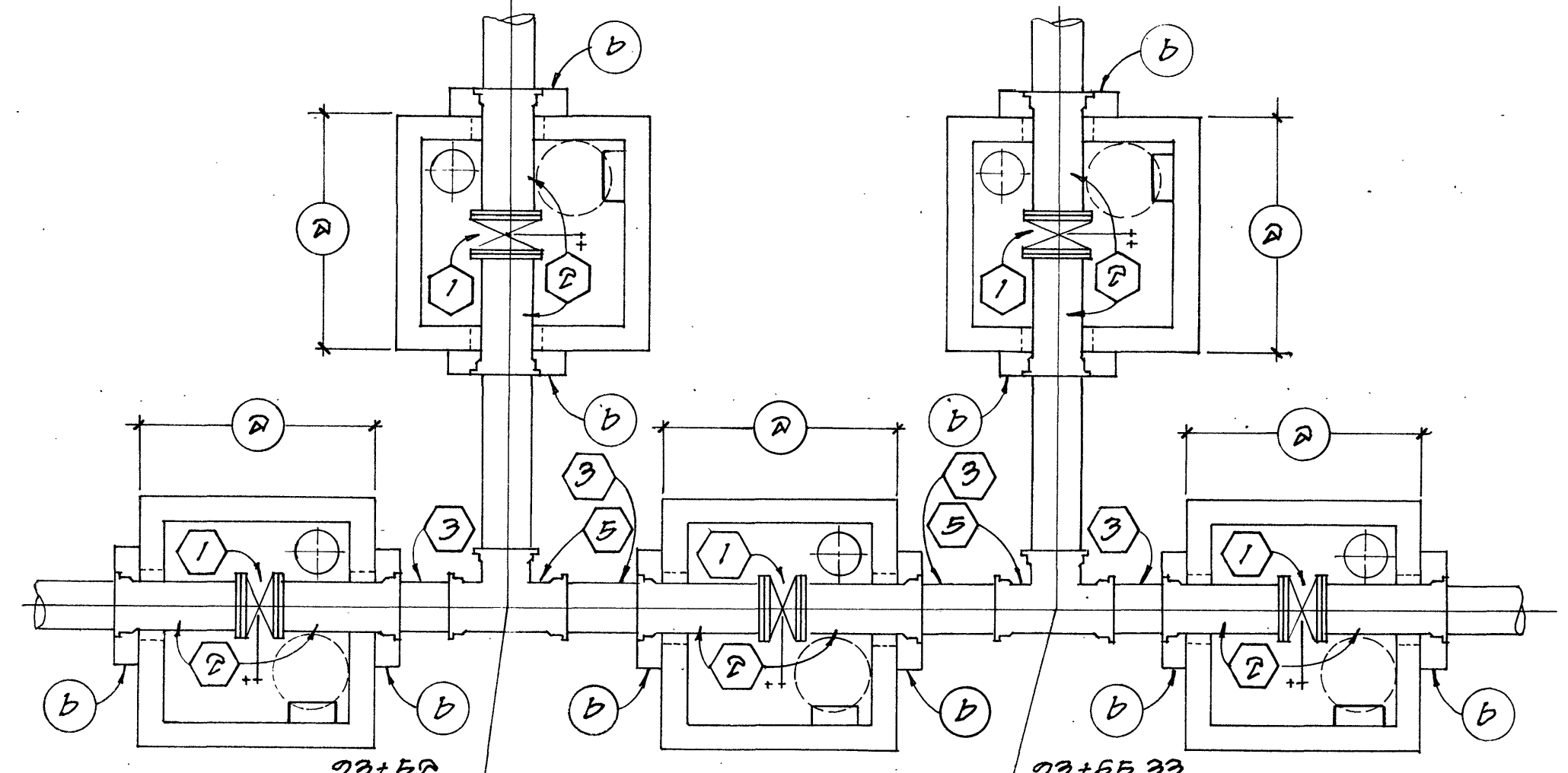

SCHEMATIC PIPING PLAN ~ 93+52 TO 93+65.33
WL "A" & WL "B" Not to scale

TYPICAL DETAILS ~ RESTORATION OF TRENCH AND PAVEMENT
NOT TO SCALE

- (A) = Type "A" Reinf. Conc. M.H. for 16" BFV
- (B) = Conc. Capping Collar ~ See detail this sheet

- LEGEND (LIST OF FITTINGS)**
- (1) 16" Butterfly Valve, F.E., Cl. 250
 - (2) 16" Adapter, Cl. 50, F & B, 3'-0" long (B)
 - (3) 16" Conc. Cylinder Pipe Adapter, F & B, 3'-0" long (A)
 - (4) 16" R.I. Nipple, F.E. & P.E., 3'-0" long, Cl. 50 (B)
 - (5) 16" Conc. Cylinder Tee, F.E. & P.E., 3'-0" long (A)
 - (6) 16" x 16" Tee, All Bell (B)
 - (7) 16" x 16" C.C. Tee, All Bell, 16" bell to fit 16" D.I. Pipe, O.D. = 16.50" (A)
 - (8) 16" x 16" Tee, All Bell (B)
 - (9) 16" x 16" Conc. Cylinder Tee, All Bell (A)

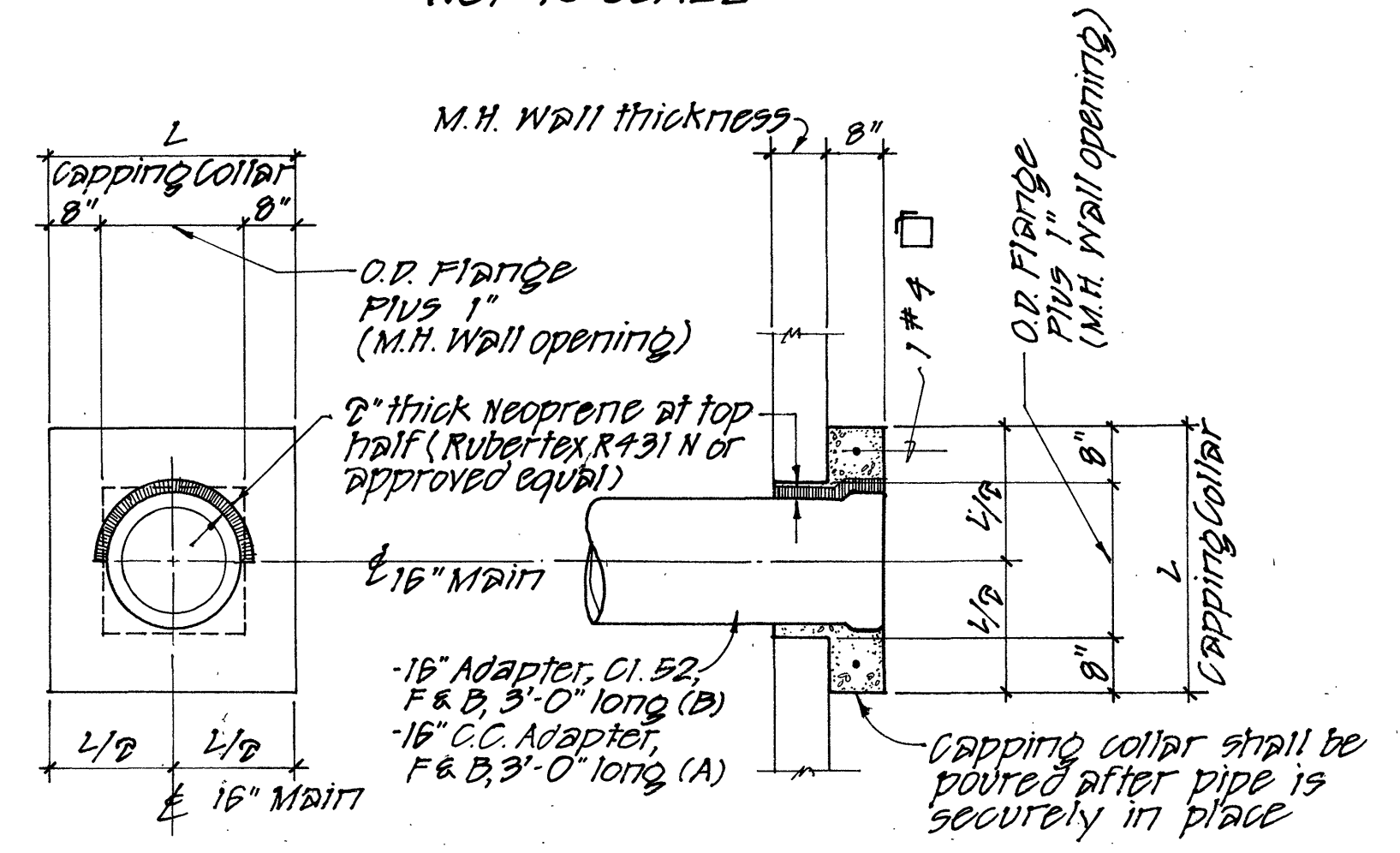

ELEVATION SECTION
CONCRETE CAPPING COLLAR DETAIL
NOT TO SCALE

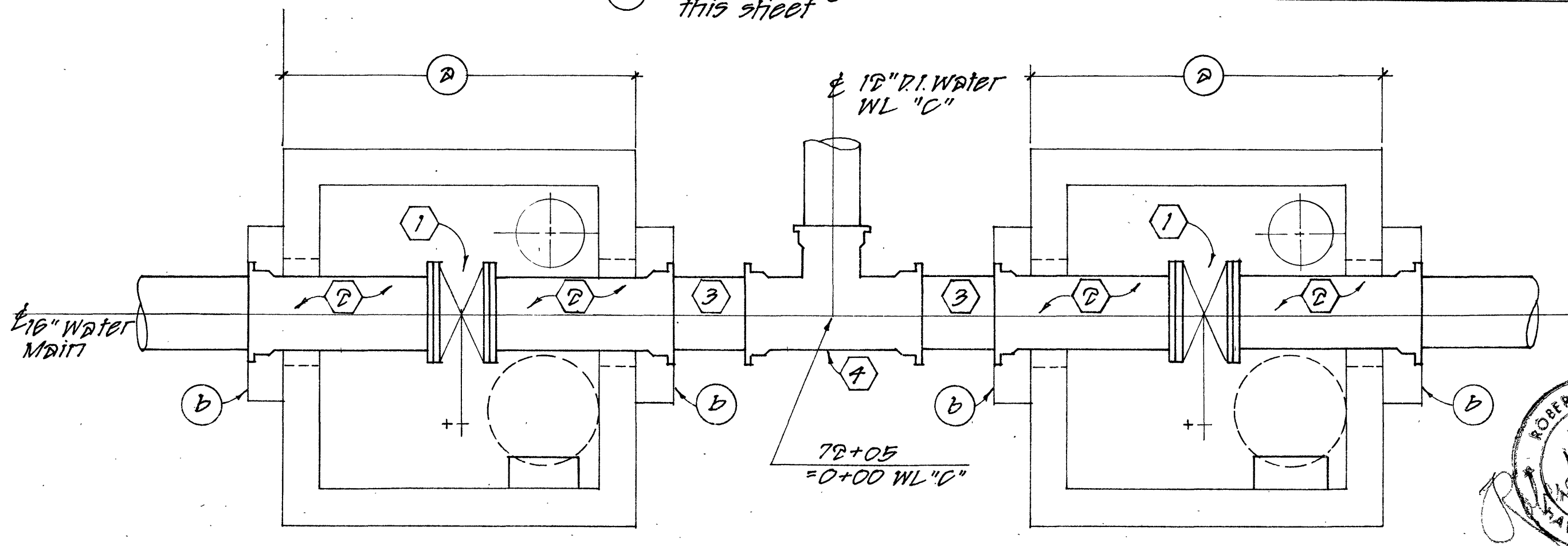

SCHEMATIC PIPING PLAN ~ 72+05
WL "C" Not to scale

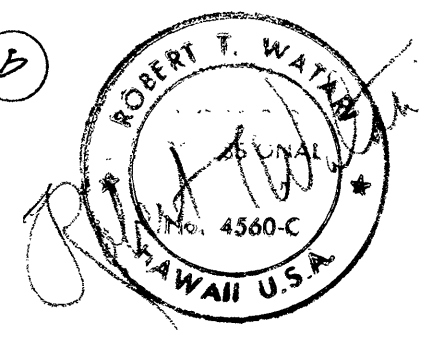

BOARD OF WATER SUPPLY CITY AND COUNTY OF HONOLULU	
JOB 92-73	
KAMEHAMEHA HIGHWAY 16" WATER MAIN	
HAUULA AND KALUANUI, KOOLAULOA, OAHU, HAWAII	
MISCELLANEOUS DETAILS	
APPROVED: <i>[Signature]</i> CHIEF, PLANNING AND ENGINEERING DIVISION	DATE: 12-5-91
DRAWN BY: <i>[Signature]</i> ENGINEER: RTW	CHECKED BY: WH FILE NO. 3-50-2-33
FIELD BOOK NO.	SCALE: AS SHOWN SHEET 15 OF 20 SHEETS

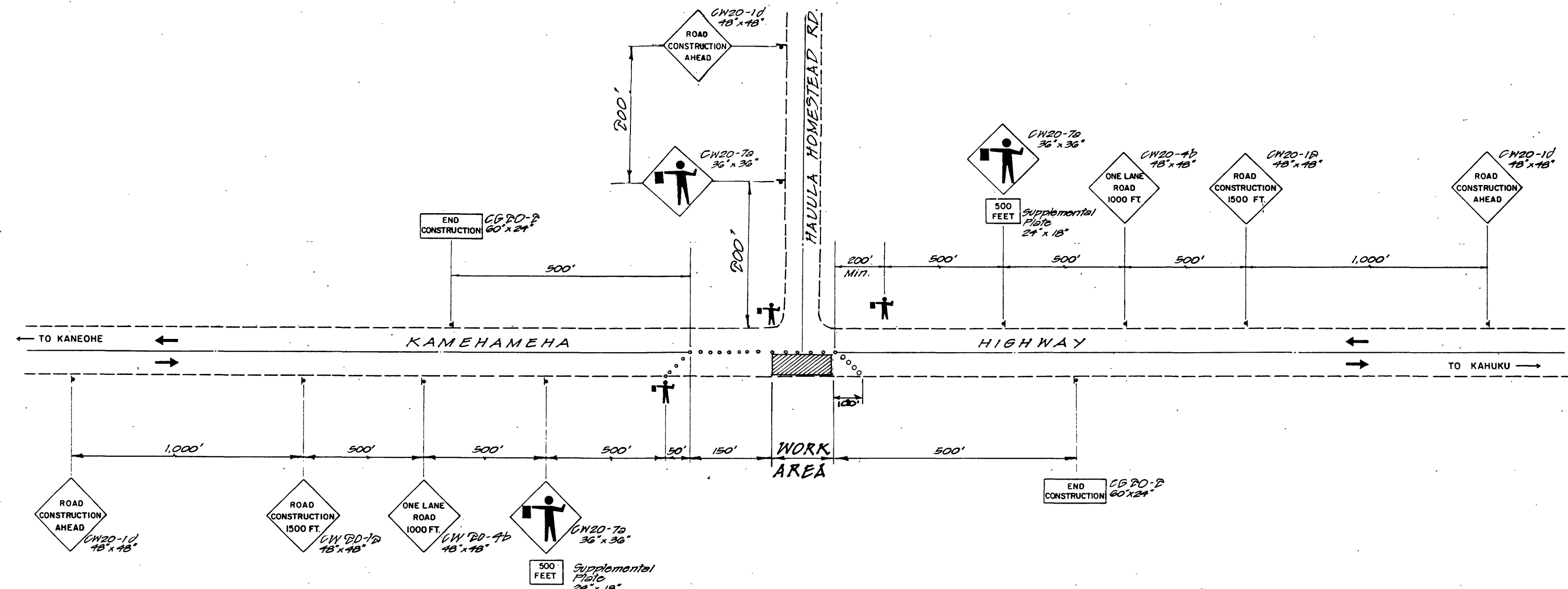

TRAFFIC CONTROL PLAN ~ STAGE 1 STA. 79+00±
NOT TO SCALE

LEGEND
 * Sign
 • Cone or Delineator
 → Direction of Traffic
 † Police Officer / Flagman

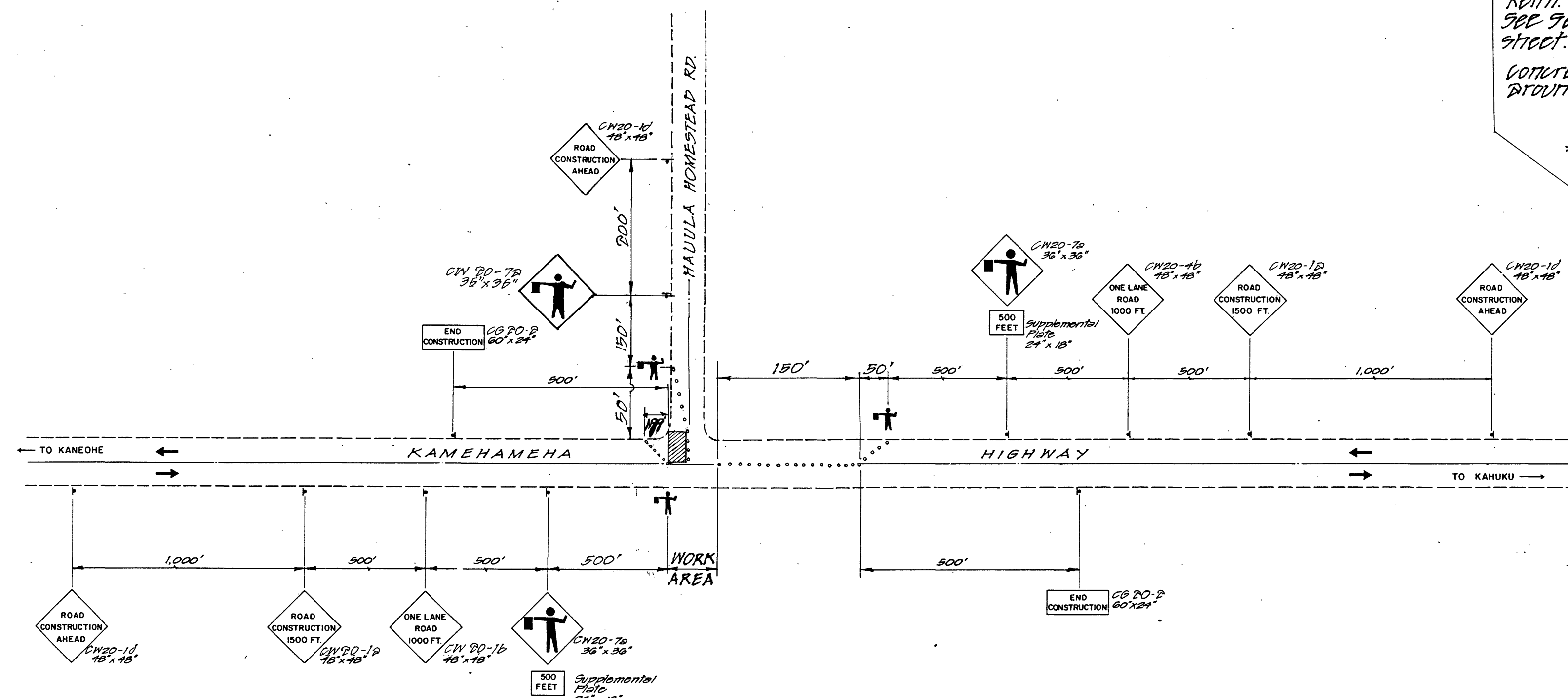

TRAFFIC CONTROL PLAN ~ STAGE 2 STA. 79+00±
NOT TO SCALE

LEGEND
 * Sign
 • Cone or Delineator
 → Direction of Traffic
 † Police Officer / Flagman

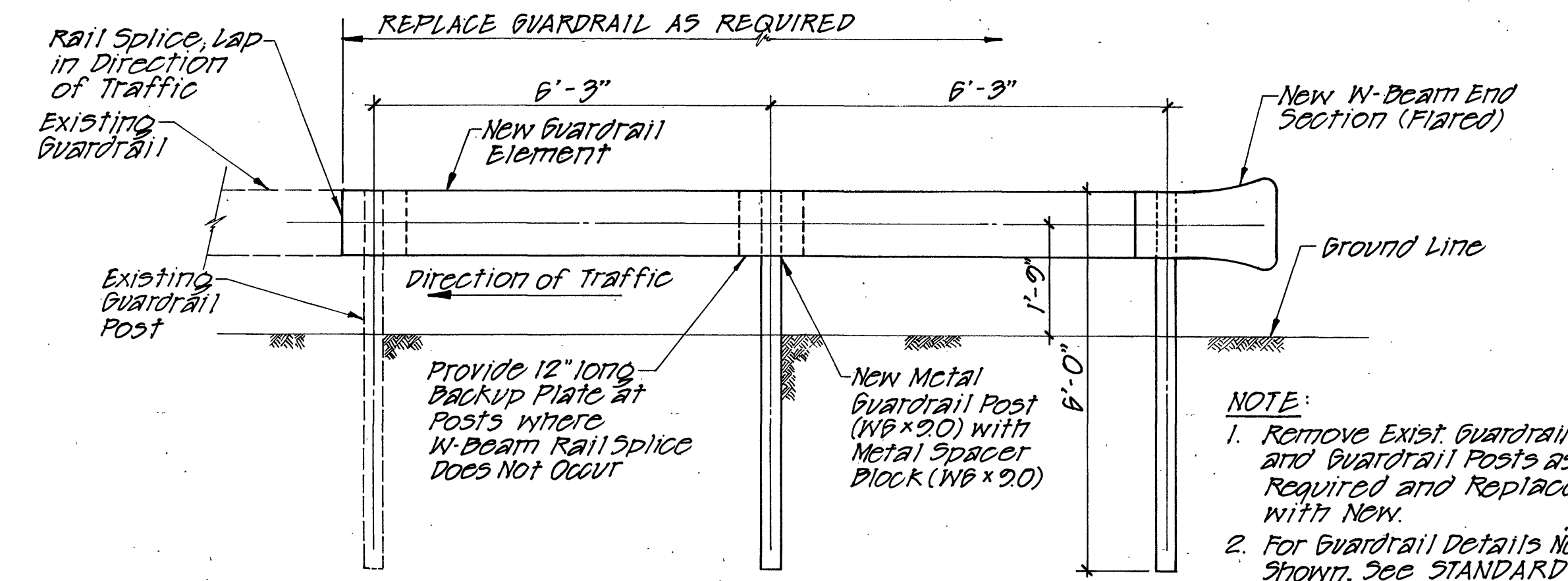

TYPICAL GUARDRAIL REPLACEMENT DETAIL
SCALE: 1" = 20'-0"

NOTE:
 1. Remove Exist. Guardrail and Guardrail Posts as Required and Replace with New.
 2. For Guardrail Details Not Shown, See STANDARD PLANS, Highways Division, Dept. of Transportation, State of Hawaii (TE-50, TE-51 & TE-60).

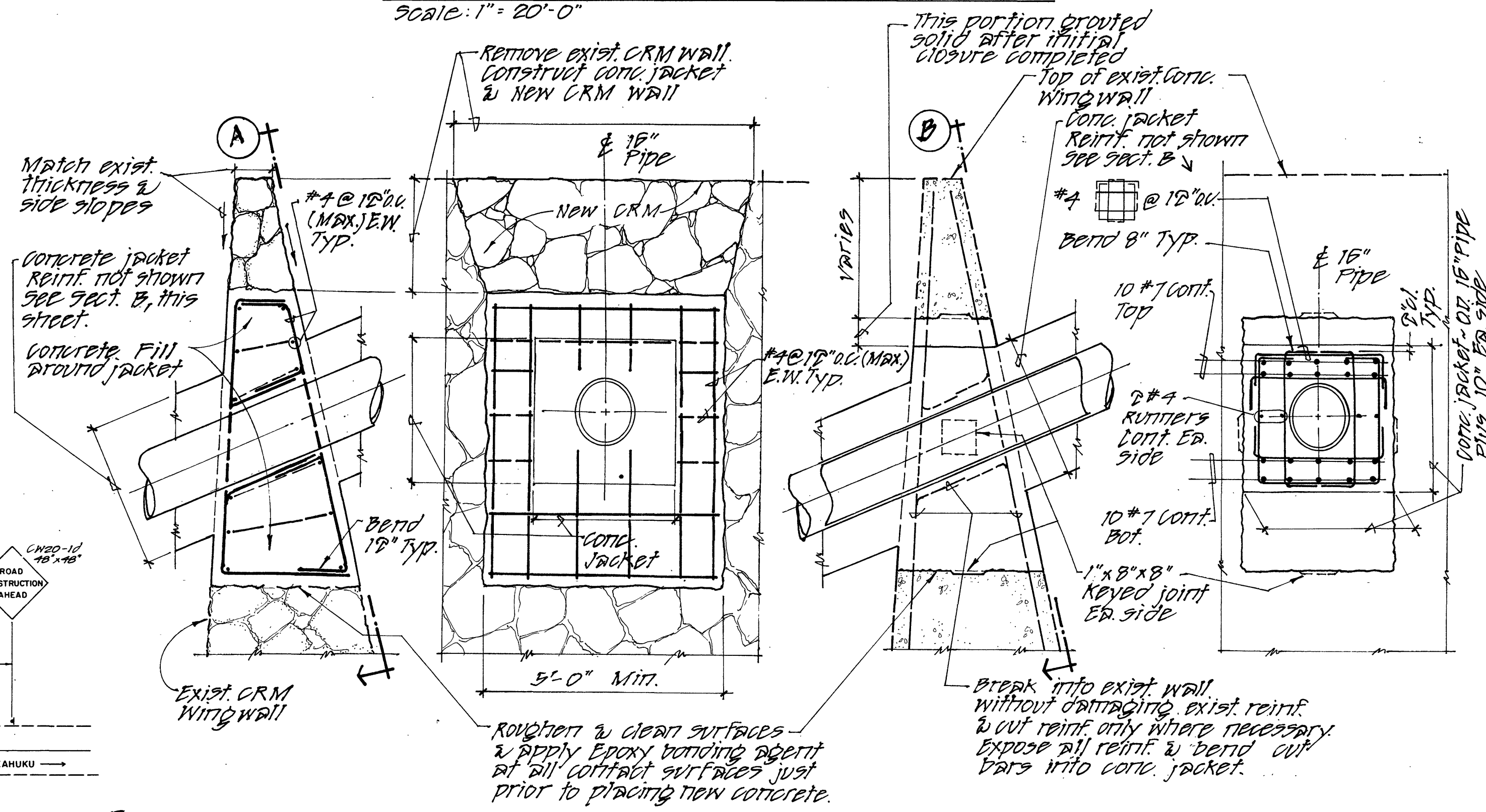

TYPICAL SECTION ~ NEW 16\"/> BRIDGE CRM WINDWALL

SECTION A

TYPICAL SECTION ~ NEW 16\"/> CONCRETE WING WALL

SECTION B

NOTE:
 See structural sheet 20 for detail not noted above

92-073

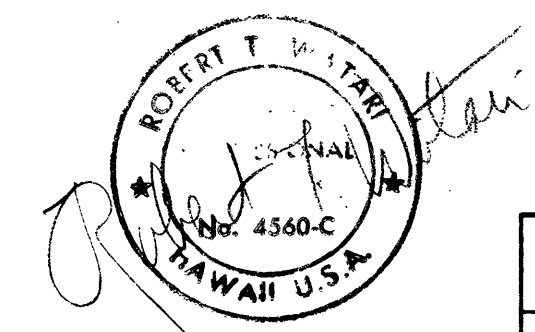

THIS WORK WAS CHECKED BY ME OR UNDER MY SUPERVISION.

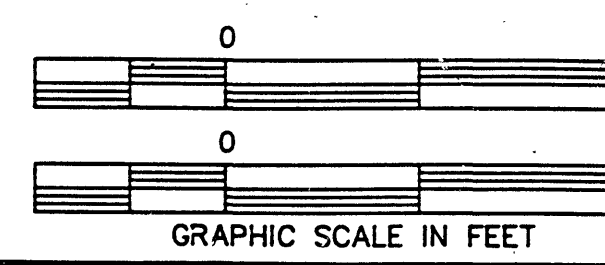

BOARD OF WATER SUPPLY CITY AND COUNTY OF HONOLULU			
JOB 92-73			
KAMEHAMEHA HIGHWAY 16\"/> WATER MAIN HAUULA AND KALUANUI, KOOLAULOA, OAHU, HAWAII			
TRAFFIC CONTROL PLANS & MISCELLANEOUS DETAILS			
APPROVED: <i>[Signature]</i>	CHIEF, PLANNING AND ENGINEERING DIVISION	DATE: 12-3-91	
DRAWN BY: <i>[Signature]</i>	ENGINEER: RTW	CHECKED BY: WH	FILE NO. 3-50-2-35
FIELD BOOK NO.	SCALE: AS SHOWN	SHEET 17	OF 20 SHEETS

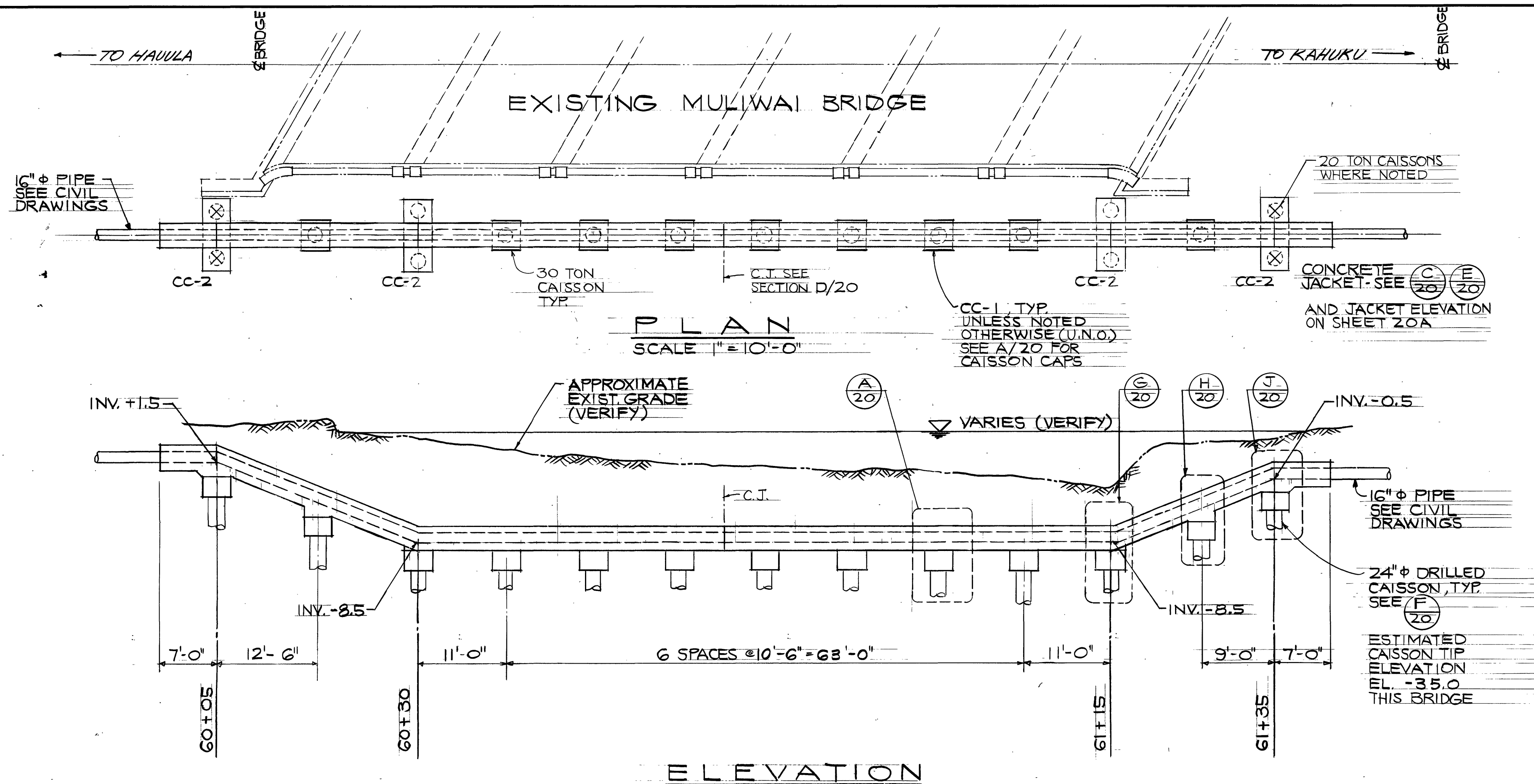

CONC. JACKET AND CAISSON FOUNDATION AT MULIwai BRIDGE
SCALE 1" = 10'-0"

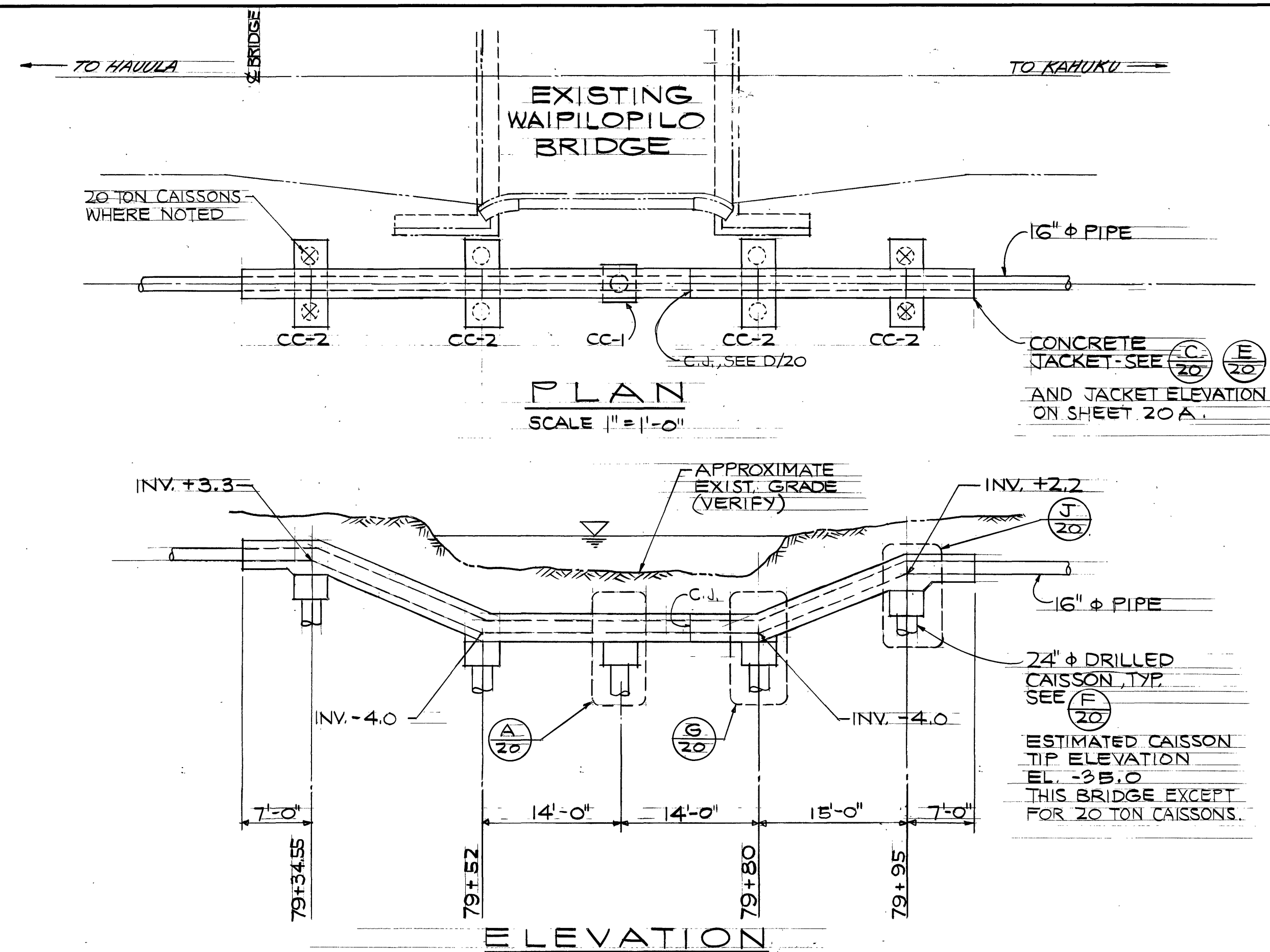

CONC. JACKET AND CAISSON FOUNDATION AT WAIPILOILO BRIDGE
SCALE 1" = 10'-0"

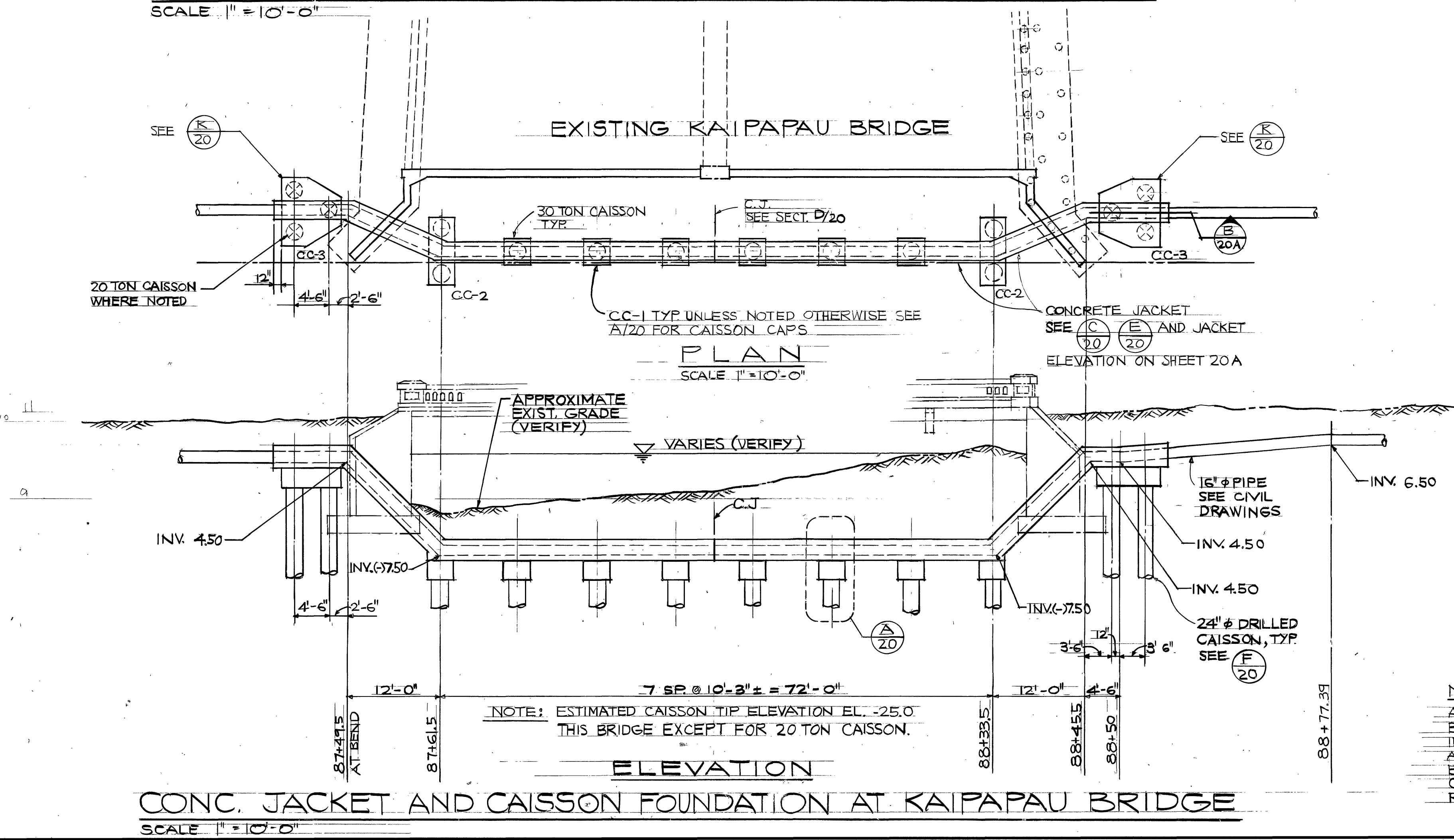

CONC. JACKET AND CAISSON FOUNDATION AT KAI PAPAU BRIDGE
SCALE 1" = 10'-0"

GENERAL NOTES

1. THE CONTRACTOR SHALL VERIFY AND COORDINATE LOCATIONS, ELEVATIONS AND DIMENSIONS WITH CIVIL DRAWINGS AND SITE CONDITION BEFORE COMMENCEMENT OF WORK.
2. ALL DRILLED CONCRETE CAISSONS SHALL HAVE A MINIMUM ALLOWABLE BEARING CAPACITY OF 30 TONS U.N.O. EMBED CAISSON TIP 10'-0" INTO MUDROCK OR EQUIVALENT DENSE STRATUM, U.N.O.
3. CAISSON DRILLING TO BE MONITORED BY SOILS ENGINEER.
4. ALL CONCRETE SHALL CONFORM TO CLASS DWS 4000 STANDARDS. CONCRETE FOR CAISSONS SHALL CONTAIN A RETARDER AND SUPERPLASTICIZER. SEE SPECIFICATIONS FOR REQUIREMENTS.
5. ALL REINFORCING STEEL SHALL BE DEFORMED BARS CONFORMED TO A.S.T.M. A615 GRADE 60 EXCEPT FOR TIES AND STIRRUPS WHICH SHALL BE GRADE 40.
6. ALL BARS IN THE CONCRETE JACKETS SHALL BE LAPPED 50 BAR DIAMETERS OR 24" WHICHEVER IS GREATER AND LAP TOP BARS AT MID-SPAN AND BOTTOM BARS AT SUPPORTS. EXCEPT WHERE NOTED OTHERWISE.
7. UNLESS OTHERWISE SHOWN ON THE DRAWING, CONSTRUCTION JOINT SHALL BE LOCATED NEAR THE MIDDLE OF CONCRETE JACKET. SEE APPLICABLE DETAILS.
8. CAISSON TIP ELEVATIONS SHOWN ARE FOR COST ESTIMATING PURPOSES ONLY. THE MUDROCK ELEVATIONS IN THE EXISTING STREAM BED VARY.
9. SOIL IN STREAM BED WHICH IS REMOVED FOR THE INSTALLATION OF CONCRETE JACKET AND THE PILE FOUNDATION SHALL BE INSTALLED TO THE ORIGINAL ELEVATION. SEE SPECIFICATIONS FOR REQUIREMENTS.
10. VERIFY 16" ϕ PIPE INVERT ELEVATIONS WITH CIVIL DRAWINGS.

LEGEND:

- 20 TON CAISSONS EMBED 5'-0" INTO MUDROCK
- 30 TON CAISSONS EMBED 10'-0" INTO MUDROCK

92-073

PCD#1		5-31-94	REVISED ENTIRE SHEET
REV.	MARK	DATE	DESCRIPTION
JOB 92-73			
BOARD OF WATER SUPPLY CITY AND COUNTY OF HONOLULU			
KAMEHAMEHA HIGHWAY 16" WATER MAIN HAUULA TO KAI PAPAU HAUULA AND KALUANUI, KOOLAULOA, OAHU, HAWAII			
PLANS AND ELEVATIONS			
APPROVED:			DATE: 6-24-94
CHIEF PLANNING AND ENGINEERING DIVISION			
DRAWN BY: M.M. ENGINEER	J.Y.	CHECKED BY: J.W.	FILE NO: 3-59-2-37
FIELD BOOK NO.	SCALE: AS NOTED	SHEET 19 OF 20 SHEETS	

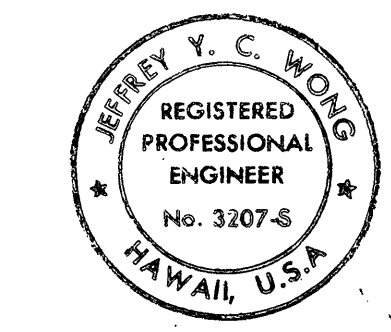

NOTE:
ALIGNMENT REVISIONS PROVIDED BY ESH ON MAY 2, 1994 ARE INCLUDED. VERIFY THAT JACKET AND CAISSONS CLEAR THE EXIST BRIDGE. SEE RESPONSE TO CONTRACTOR'S CLARIFICATION REQUEST NO. 1.

This work was prepared by me or under my supervision.

NTW ASSOCIATES, INC.
Structural Engineers

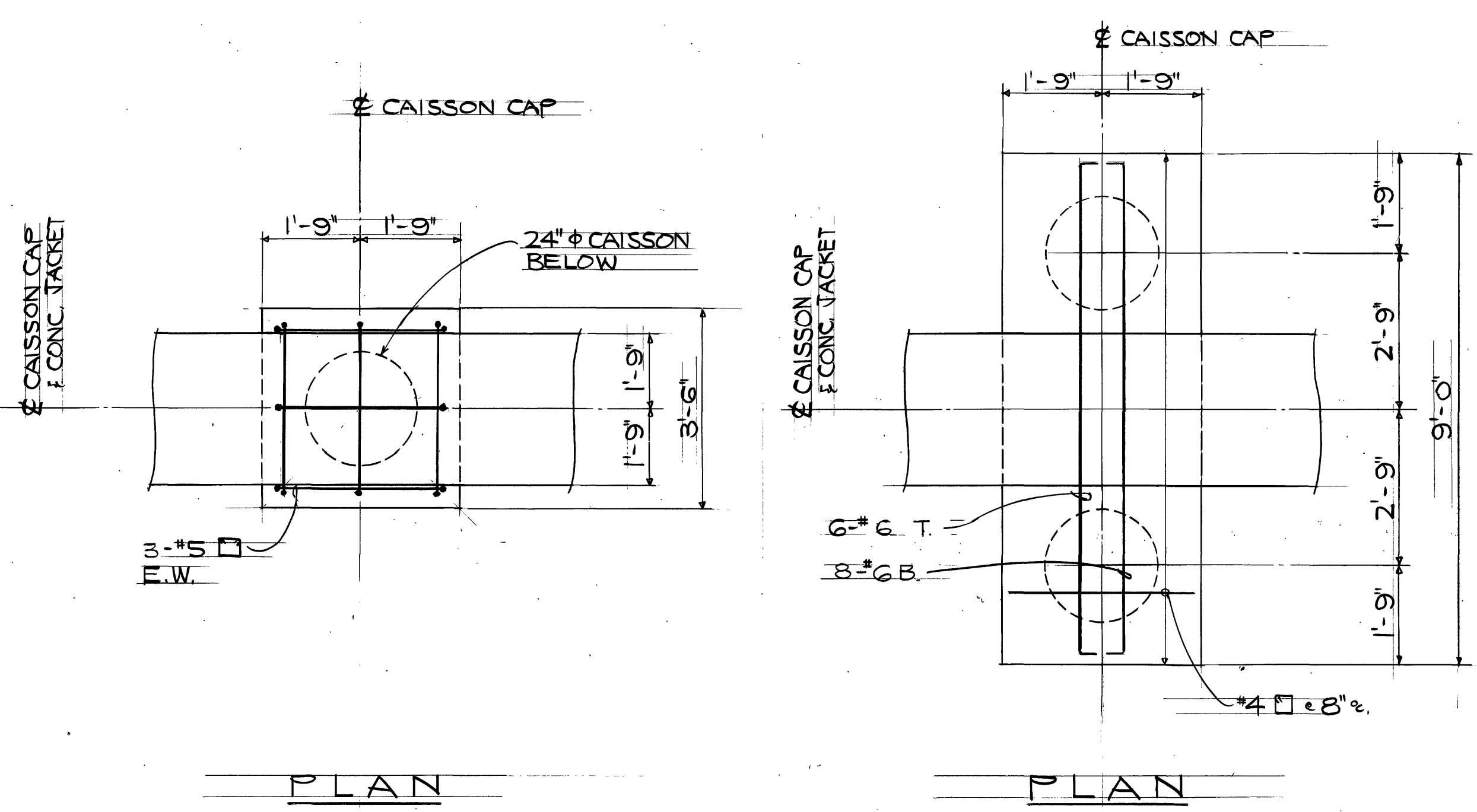

PLAN

PLAN

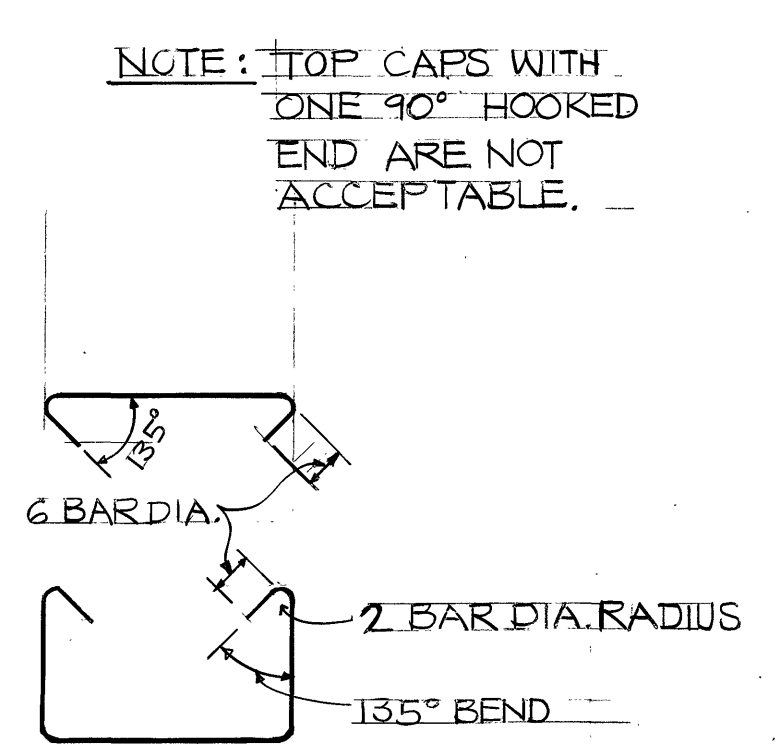

TYPICAL STIRRUP (B/20)
NOT TO SCALE

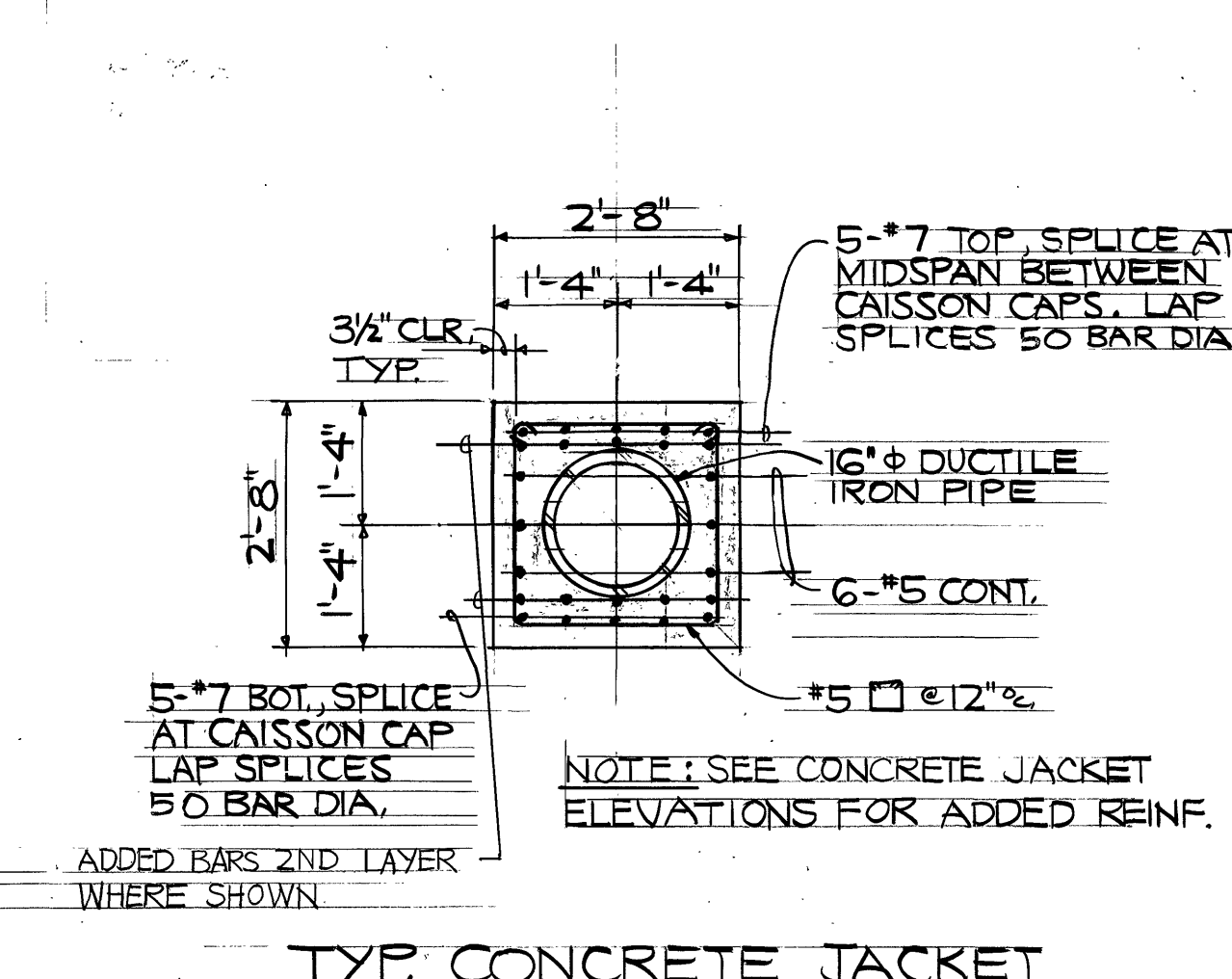

TYP. CONCRETE JACKET

SECTION (C/20)
SCALE 1/2" = 1'-0"

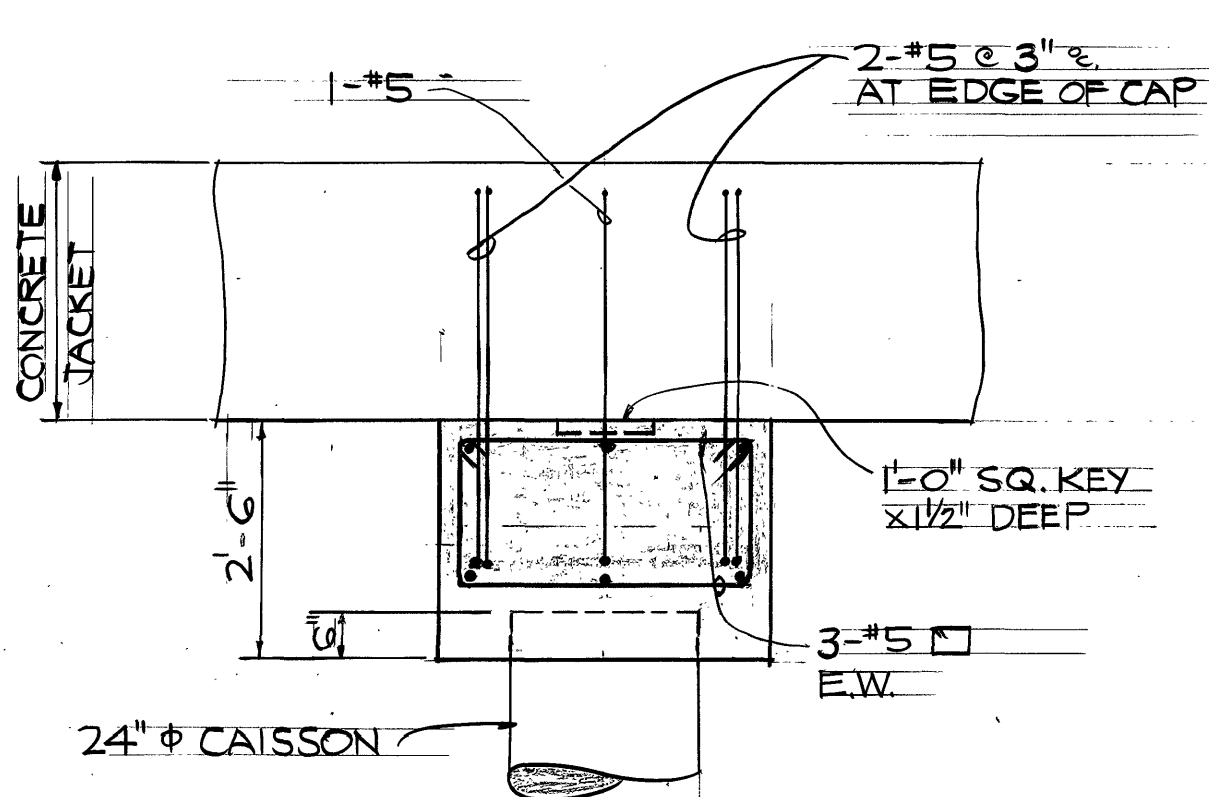

CAISSON CAP CC-1

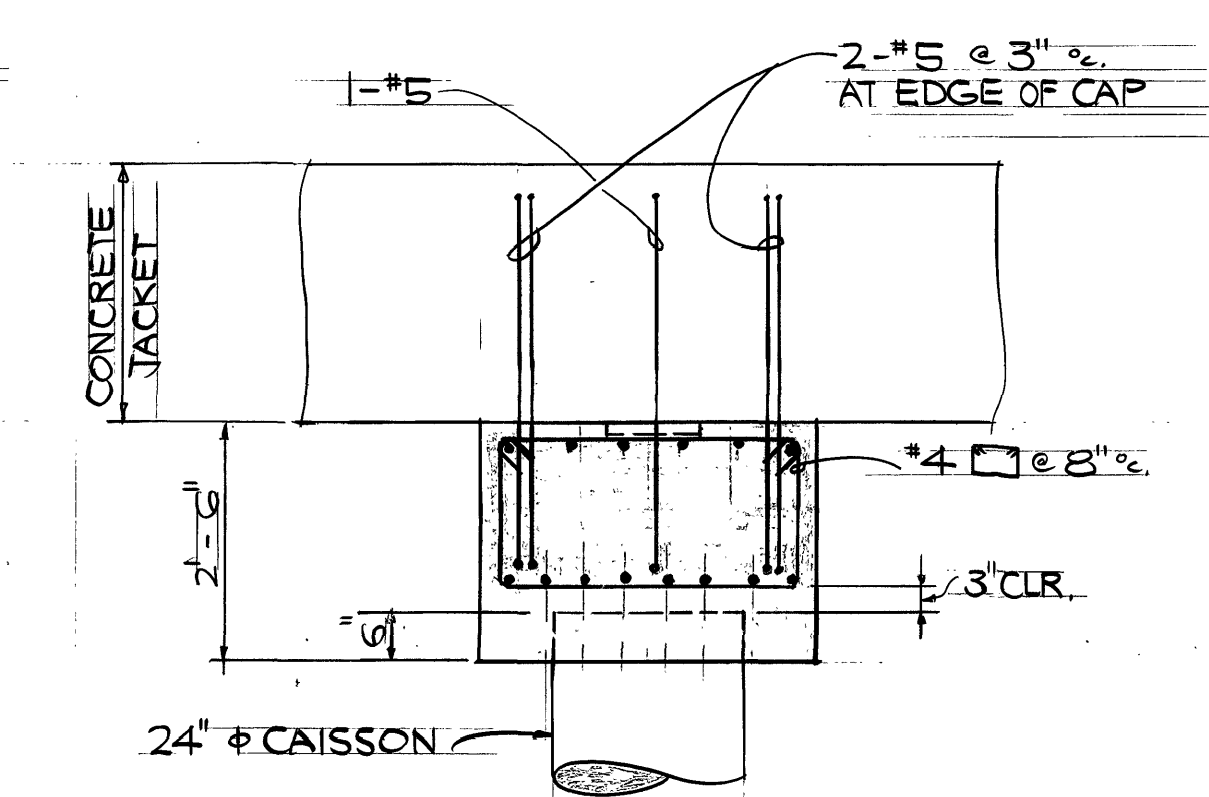

CAISSON CAP CC-2

TYPICAL CAISSON CAP (A/20)
SCALE 1/2" = 1'-0"

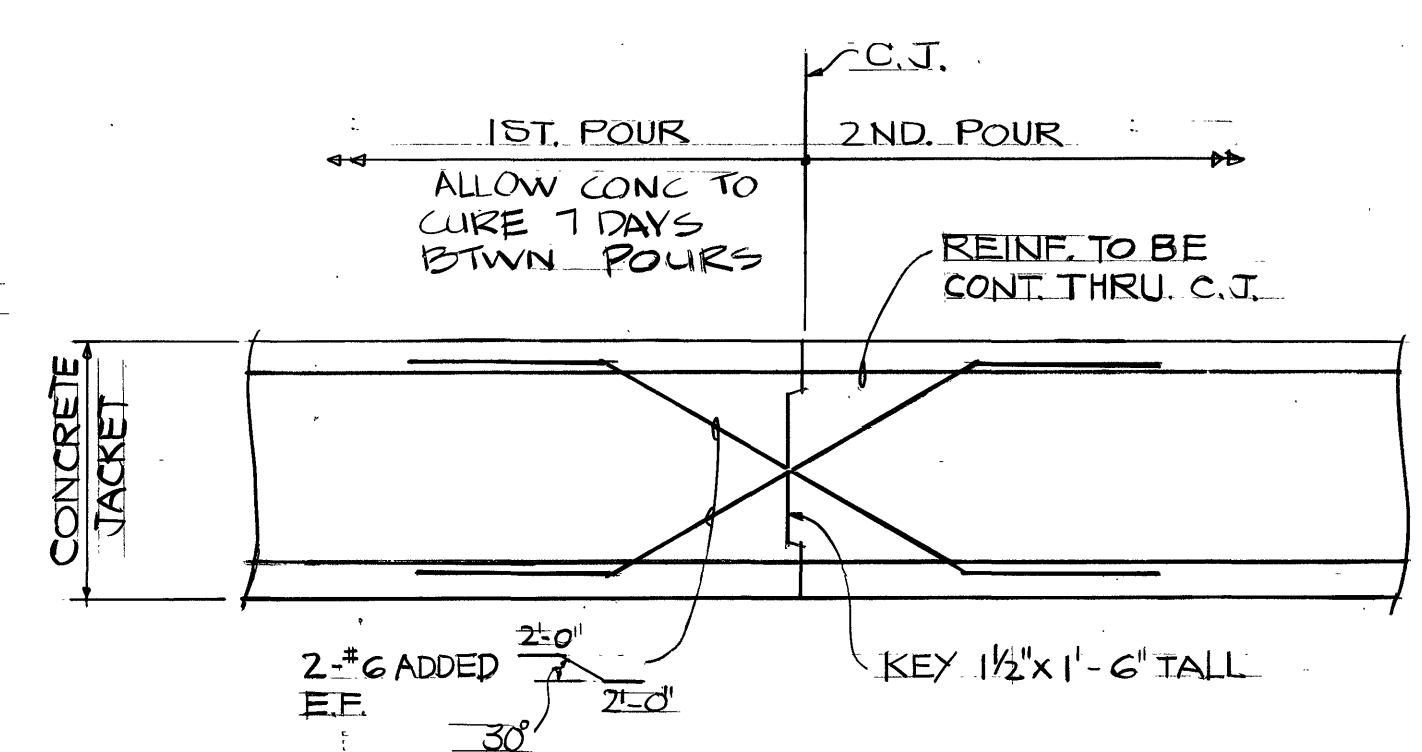

TYP. CONSTRUCTION JOINT (C.J.) (D/20)
SCALE 1/2" = 1'-0"

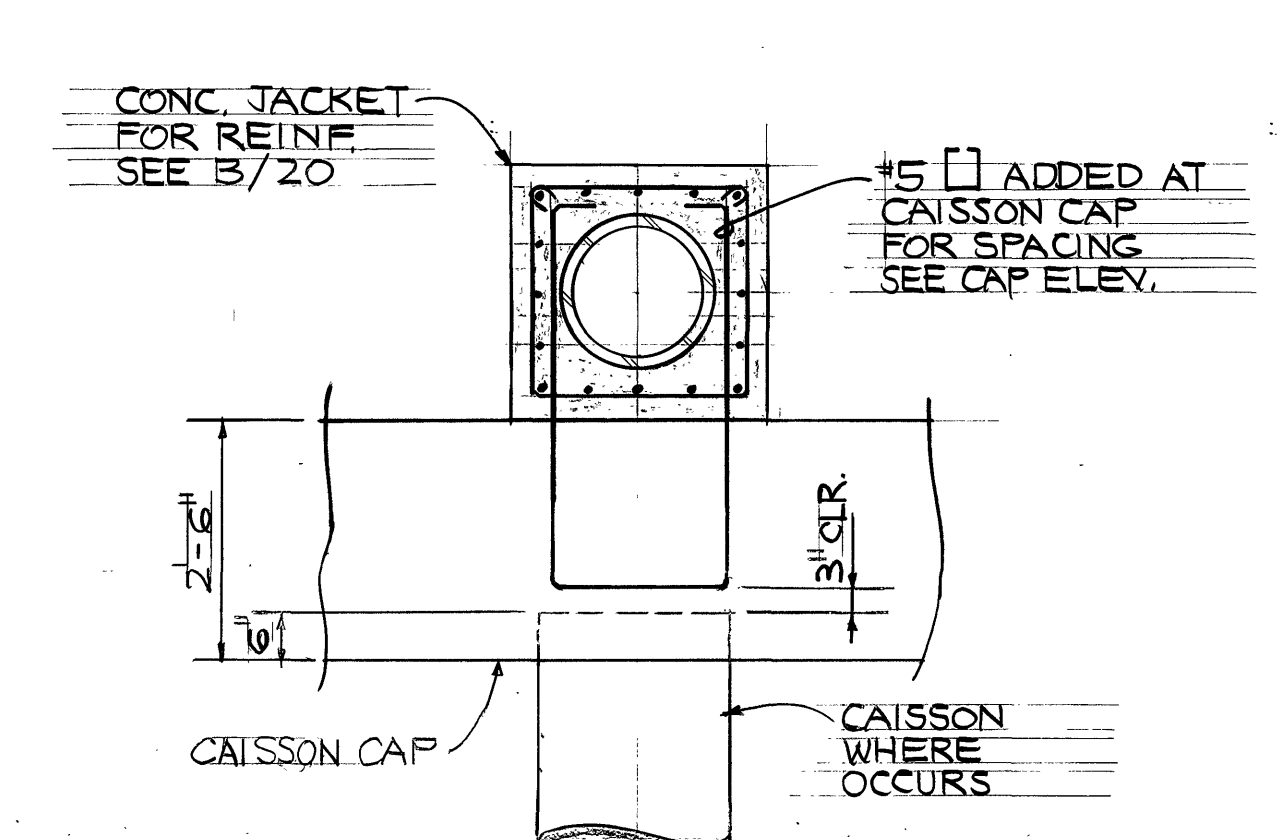

TYP. CONCRETE JACKET AT CAISSON

SECTION (E/20)
SCALE 1/2" = 1'-0"

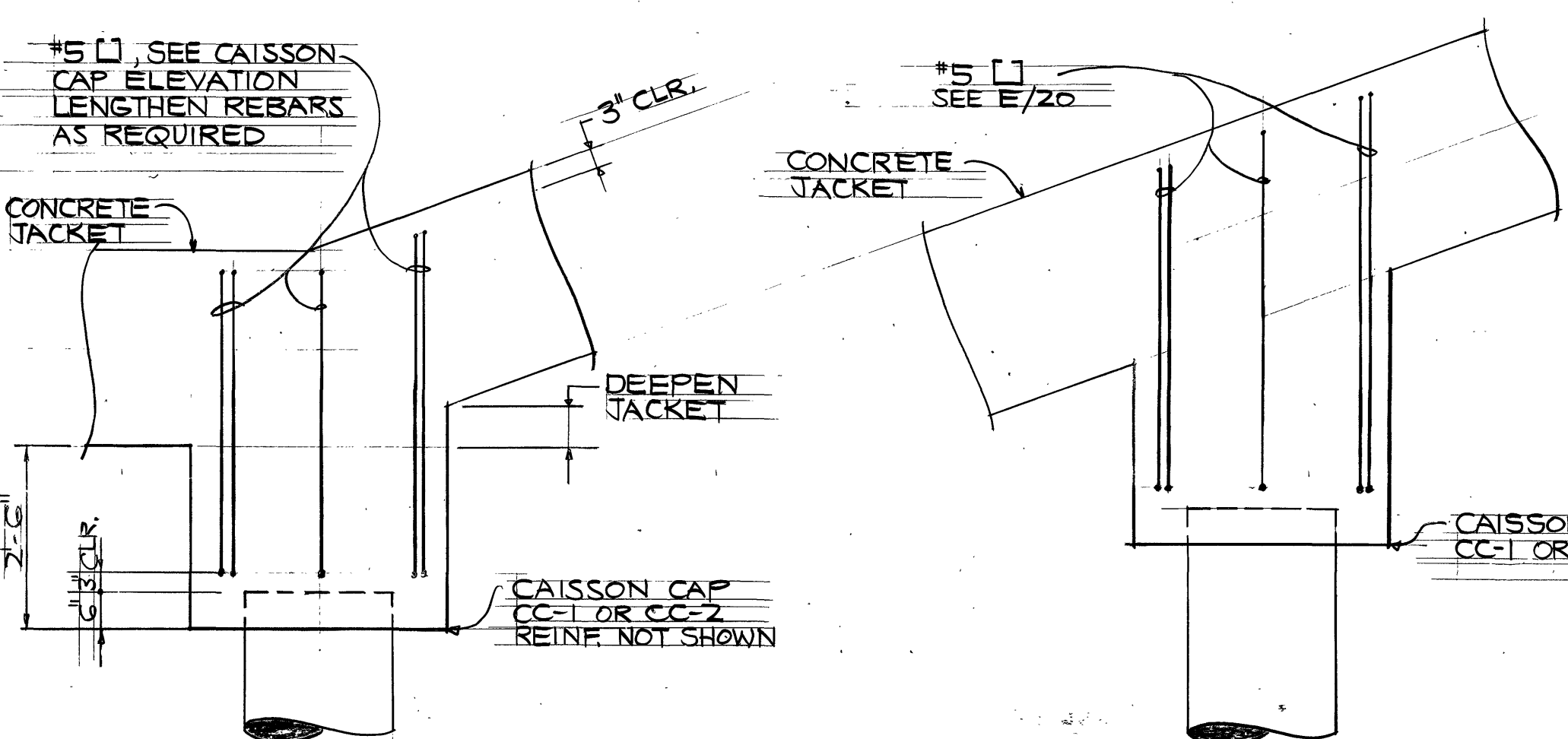

SECTION (G/20)
SCALE 1/2" = 1'-0"

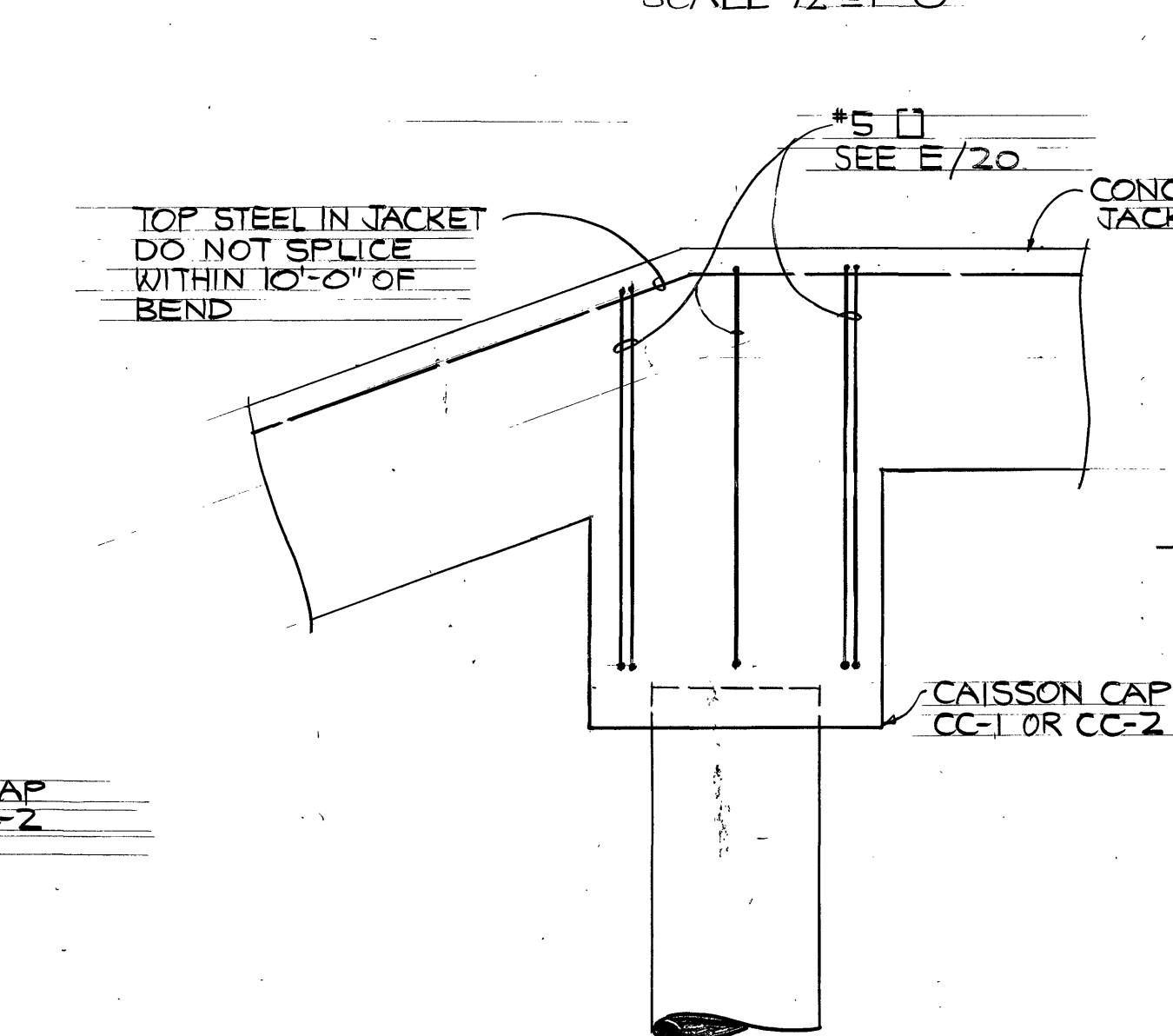

SECTION (H/20)
SCALE 1/2" = 1'-0"

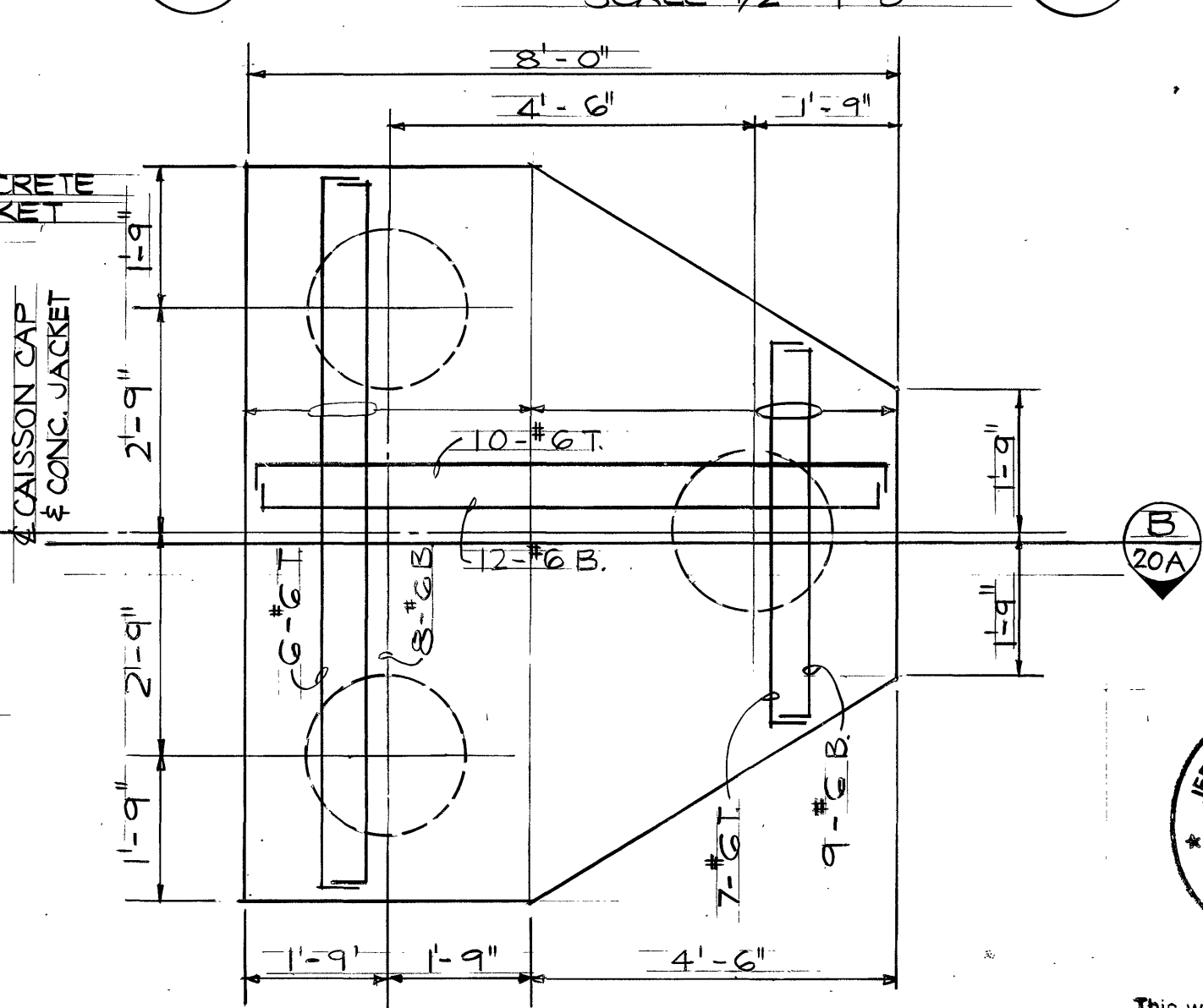

SECTION (J/20)
SCALE 1/2" = 1'-0"

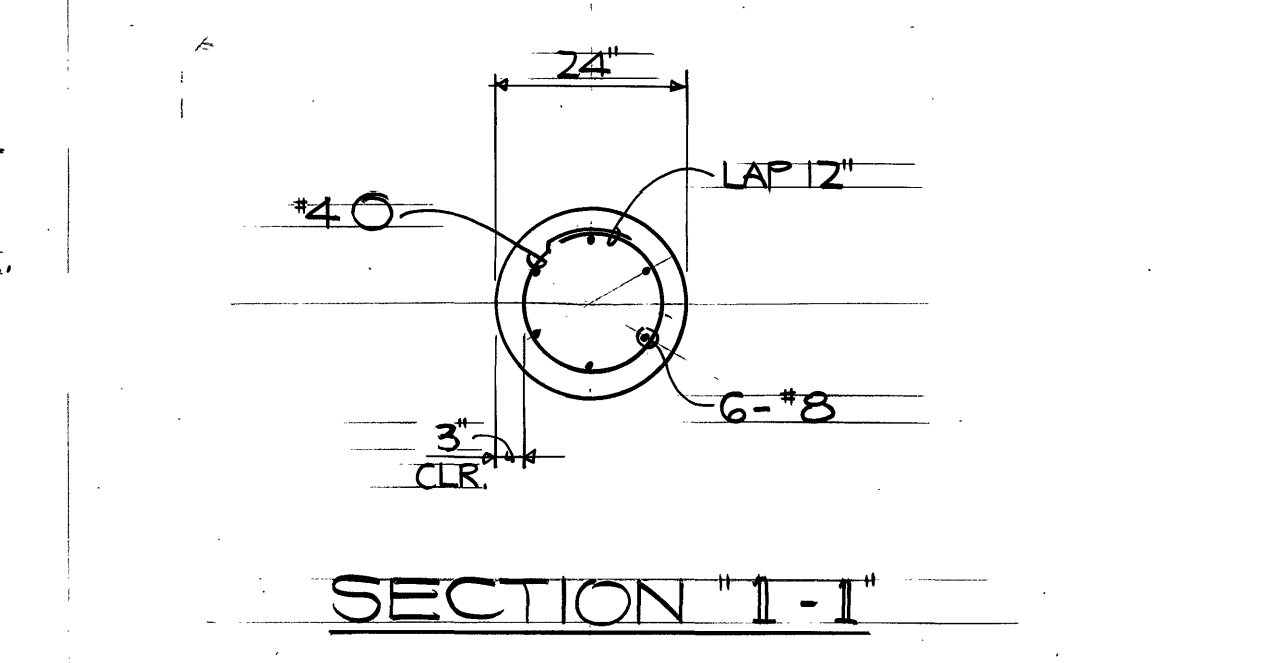

SECTION "I-1"

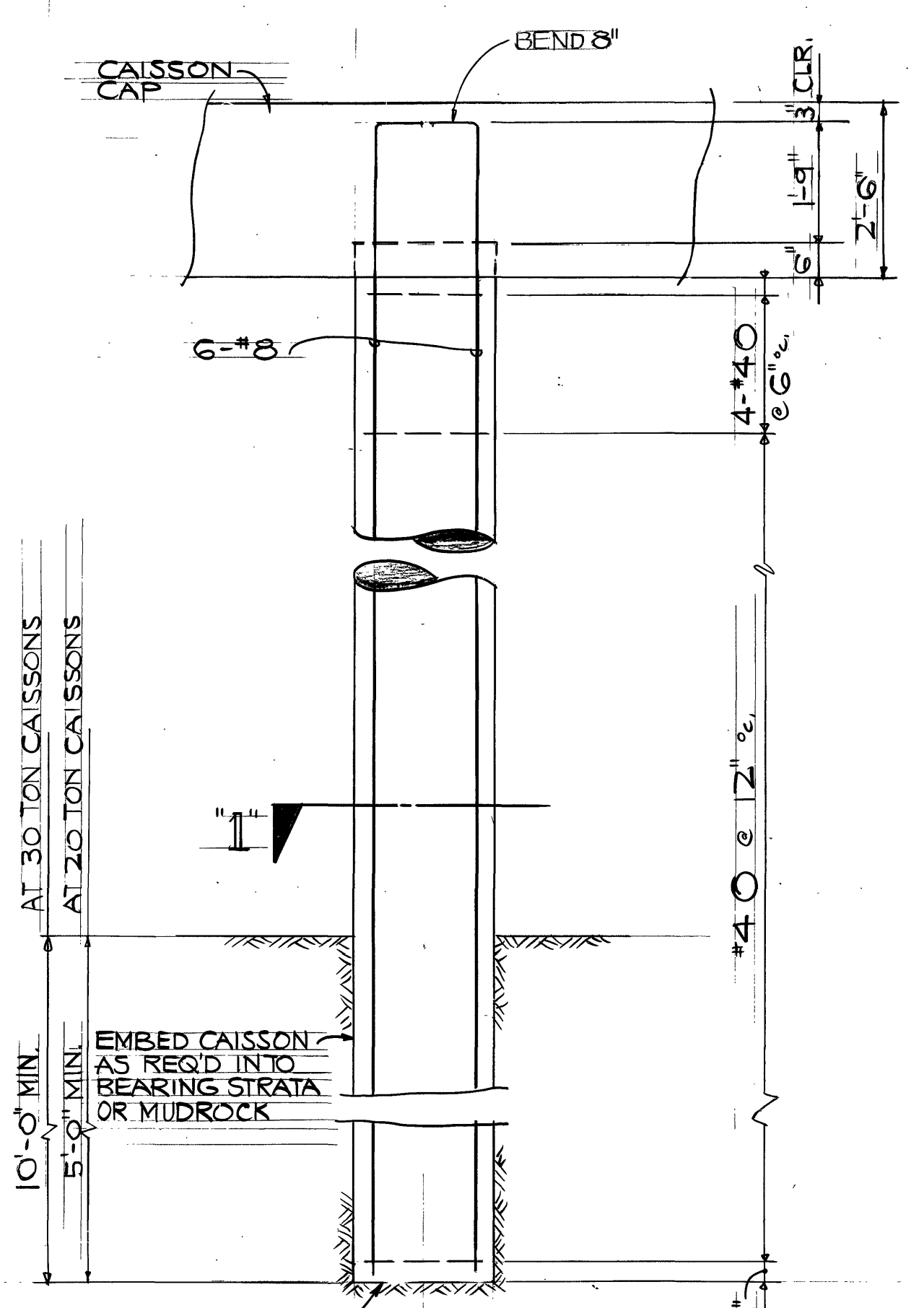

TYP. CAISSON ELEV. (F/20)
SCALE 1/2" = 1'-0"

ESTIMATED TIP ELEVATION, SEE PLAN. TIP ELEVATIONS PROVIDED FOR COST ESTIMATE PURPOSES ONLY.

92-073

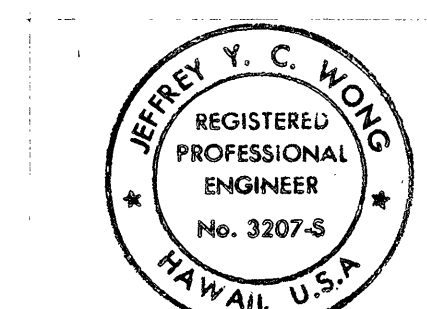

This work was prepared by me or under my supervision.
NTW ASSOCIATES, INC.
Structural Engineers

PCD #1	5-31-94	REVISED ENTIRE SHEET
REV.	MARK	DATE
		DESCRIPTION
JOB 92-73		
BOARD OF WATER SUPPLY CITY AND COUNTY OF HONOLULU		
KAMEHAMEHA HIGHWAY 16" WATER MAIN HAULA TO KAIAPAU		
HAULA AND KALUANUI, KOOLAULOA, OAHU, HAWAII		
SECTIONS AND DETAILS		
APPROVED:	<i>[Signature]</i>	DATE: 8-27-94
DESIGNED BY:	M.M.	ENGINEER: J.Y.
CHECKED BY:	J.W.	FILE NO. 3-59-2-38
FIELD BOOK NO.	SCALE: AS NOTED	SHEET 20 OF 20 SHEETS

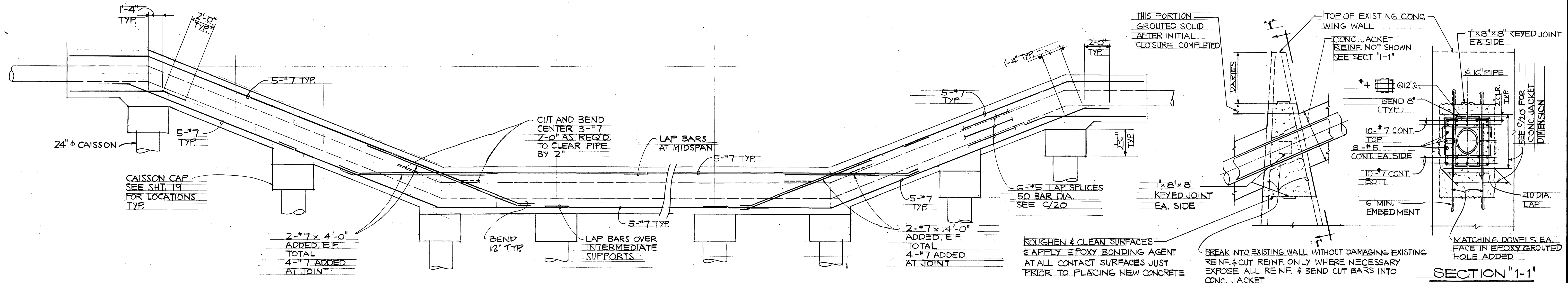

CONCRETE JACKET ELEVATION AT MULIWAH BRIDGE

SCALE 1/4" = 1'-0" HORIZ.
3/8" = 1'-0" VERT.

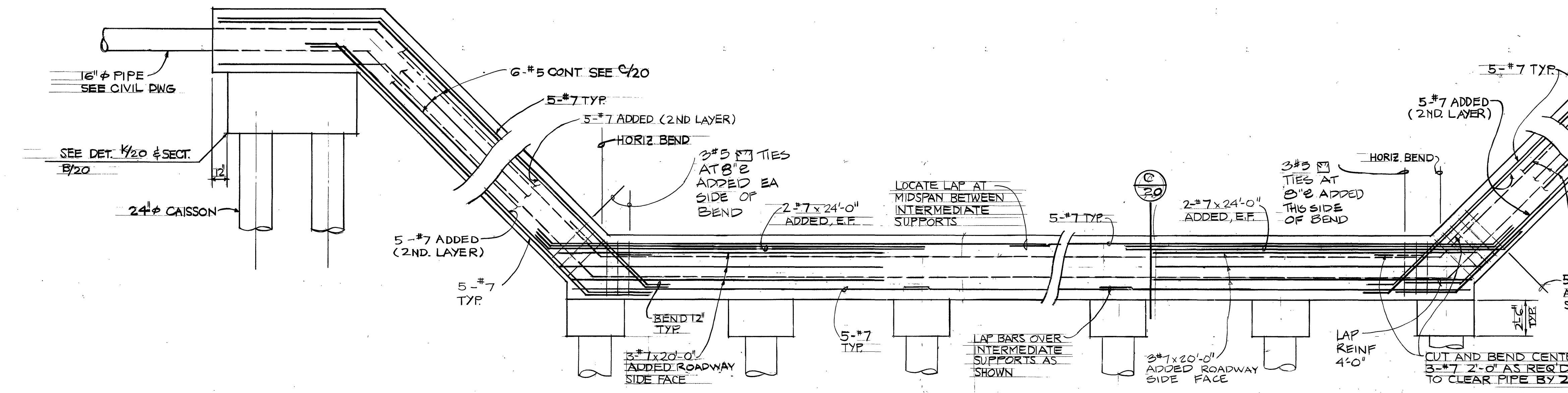

CONCRETE JACKET ELEVATION AT KAIPAPAU BRIDGE

SCALE 1/4" = 1'-0" HORIZ.
3/8" = 1'-0" VERT.

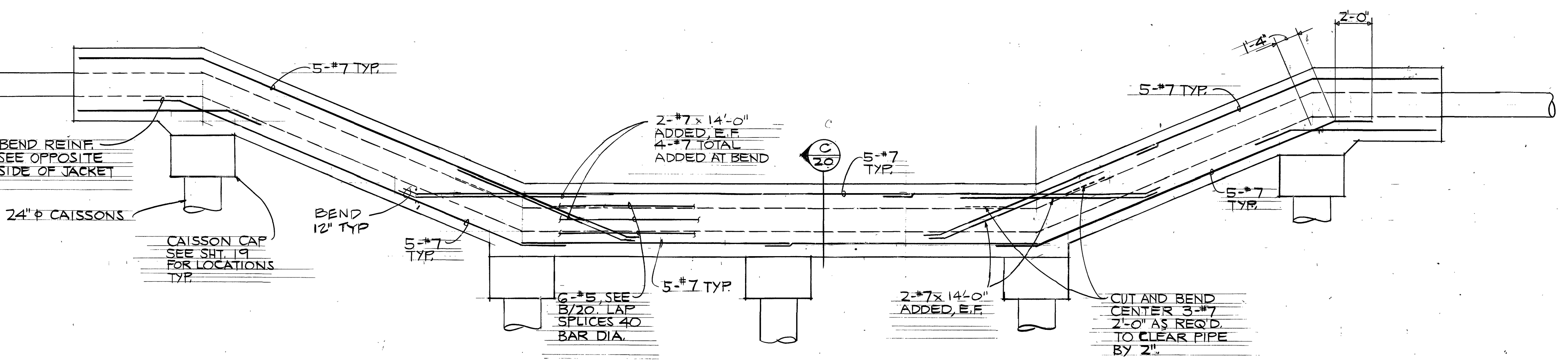

CONCRETE JACKET ELEVATION AT WAIPILOPILO BRIDGE

SCALE 1/4" = 1'-0" HORIZ.
3/8" = 1'-0" VERT.

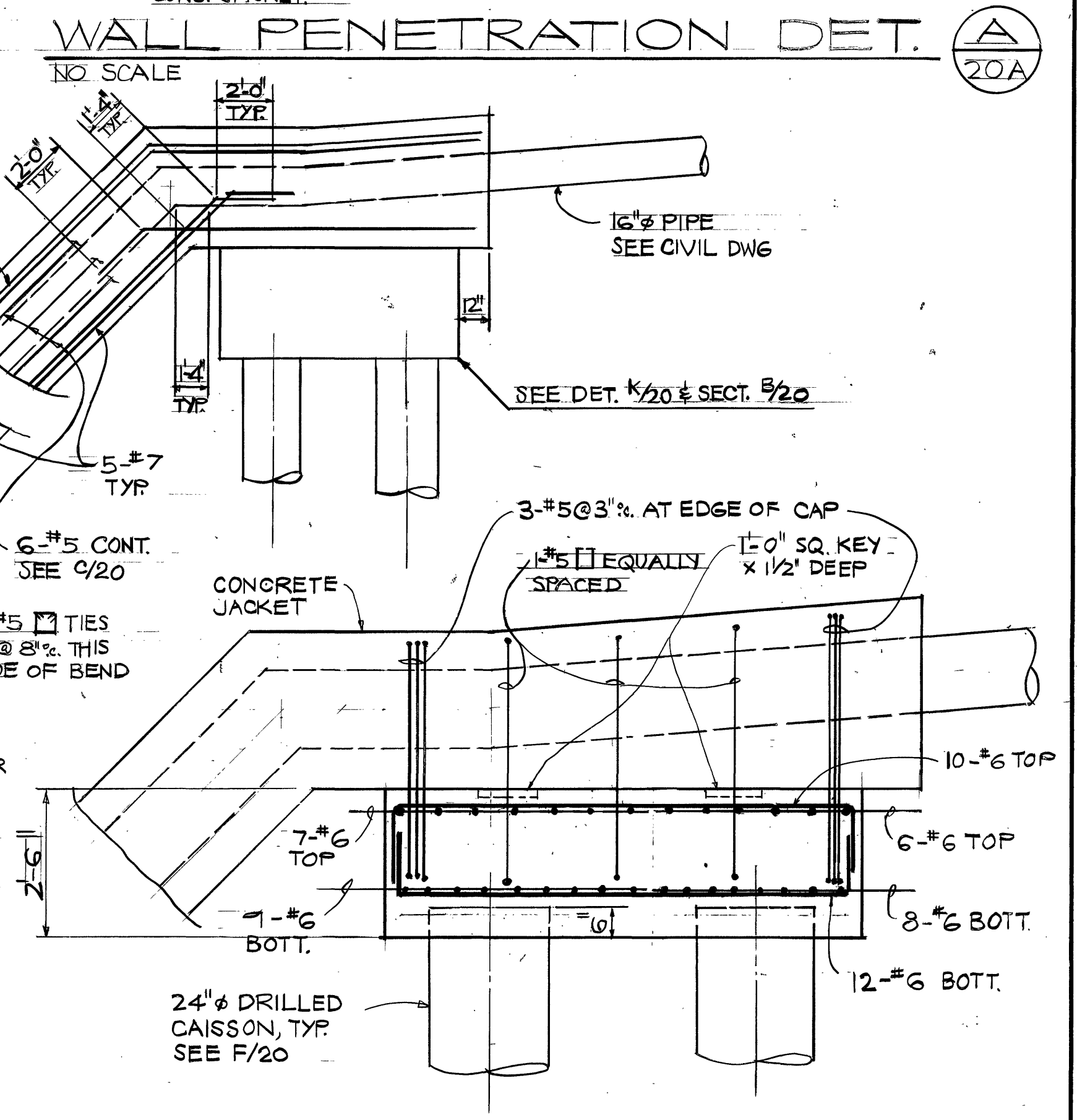

WALL PENETRATION DET.

NO SCALE

SECTION 1-1
20A

92-073

SECTION B
SCALE 1/2" = 1'-0"

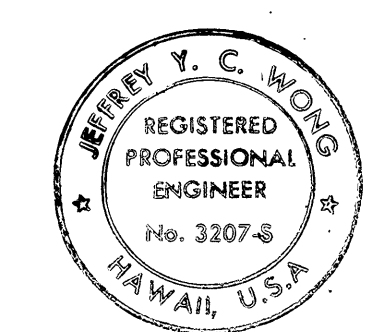

This work was prepared by me or under my supervision.
J. Wong
J.W. WONG & ASSOCIATES, INC.
Structural Engineers

PCD#1	A	5-31-94	
REV.	MARK	DATE	DESCRIPTION
JOB 92-73			
BOARD OF WATER SUPPLY CITY AND COUNTY OF HONOLULU			
KAMEHAMEHA HIGHWAY 16" WATER MAIN HAULA TO KAIPAPAU HAULA AND KALUANUI, KOOLAULOA, OAHU, HAWAII			
CONCRETE JACKET ELEVATIONS			
APPROVED:	[Signature]		DATE: 6-27-94
DRAWN BY: M.M. ENGINEER: J.Y. CHECKED BY: J.W. FILE NO: 3-59-2-37			
FIELD BOOK NO.	SCALE: AS NOTED	SHEET 20A OF 21 SHEETS	